

Twils[®] LOUNGE

Twils® LOUNGE

Living vol.2

Contents.

<i>Free</i>	~ 07
<i>Share</i>	~ 033
<i>Balmoral</i>	~ 069
<i>Open</i>	~ 089
<i>èS.</i>	~ 0107
<i>Finn</i>	~ 0133
<i>Revival</i>	~ 0159
<i>Graffiti</i>	~ 0169





Per rappresentare il nostro brand e il suo spirito, raccontare chi siamo, mostrare senza filtri e sovrastrutture la qualità dei materiali e delle soluzioni tessili che rendono unico il mondo Twils Lounge®. Un mondo di ottimo design, stile inconfondibile e confort.

To represent our brand and its spirit, say who we are, show the quality of the materials and textile solutions that make the world of Twils Lounge® so unique without filters or superfluous elements. A world of outstanding design, unmistakable style and confort.

Twils LOUNGE

Abbiamo scelto di ambientare i nostri divani all'interno di spazi vissuti, ricchi di luce e di verità. Un tributo alla quotidianità, ma anche il palcoscenico ideale per un percorso attraverso le nuove collezioni.

We chose to place our sofas in real-life settings, flooded with light and truth. A tribute to everyday life but also the ideal stage to showcase our new collections.



Name sofa:
Free

~
Design:
R&D Twils

Il mondo contemporaneo è sempre più interconnesso, poliedrico e flessibile. Anche il design deve farsi interprete di questa continua evoluzione, esprimere il cambiamento, adeguare i propri codici espressivi.

Da questo intento nasce Free, un sistema di sedute destrutturato e libero, in grado di adattarsi all'ambiente e alle esigenze di chi lo usa, sempre pronto a conformarsi o a variare, assecondando ogni nostra trasformazione.

Today's world is increasingly interconnected, versatile and flexible. Even design has to keep up with this continuous evolution, follow the changes, adapt its expressive codes.

This is the inspiration for Free, a free, unstructured range of sofas which adapts to any room and the needs of those who use it, ready to conform or change, satisfying our every transformation.

Free





Name sofa:
Free
~
Design:
R&D Twils
~
Shoot:
Free entry

BORN TO BE FREE

TOGETHER

L'ispirazione è data dalla contemporaneità, con un sottinteso riferimento a un'ospitalità informale e sincera che evoca l'oriente. Free ci invita al relax senza porre condizioni, se non quella del nostro assoluto comfort. La seduta è un semplice sommier, sorretto da eleganti piedini a slitta in metallo brunito. La morbidezza traspare in superficie.

The inspiration comes from contemporary life, influenced by genuine, informal hospitality which conjures up images of the East. Free invites us to relax without dictating conditions, the only one being our comfort. The seat is a simple sommier, sitting on an elegant sled base in burnished metal. The softness shows through on the surface.

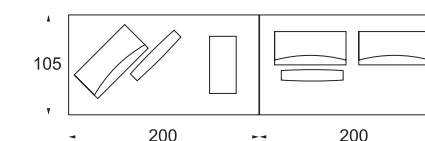

010
GE
L
C
NE

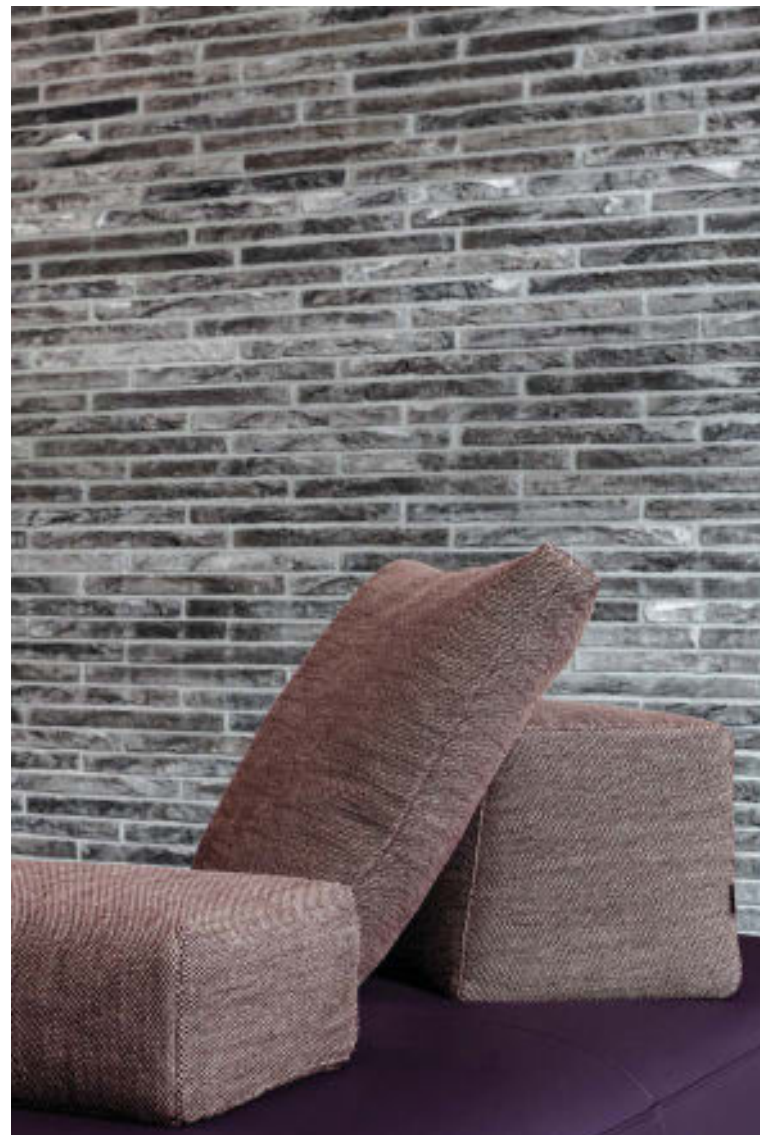

NEVER STOP DREAMING

LIFE

La base è completata dagli schienali a posizionamento libero, con supporto antiscivolo. Finalmente liberi di stabilire dove porli, potremo poi disporre a nostro piacimento i soffici cuscini quadrati e i braccioli, creando la nostra esclusiva isola di comfort.

The base is completed by backrests which can be placed in any position and have a non-slip bottom. At long last, we are free to decide where to put them, along with the soft square cushions and armrests, creating our own exclusive island of comfort.



*Sappiamo cosa siamo,
ma non sappiamo
cosa potremmo essere.*

*We know what we are,
but know not what
we may be.*

William Shakespeare

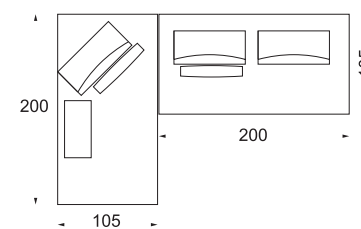

Cat. E-Plus Art. 831/110



Cat. K Art. C78/002



011

Name sofa:
Free
~
Design:
R&D Twils
~
Shoot:
Geometries of light

MAKE IT HAPPEN

*Quando perdiamo il diritto
di essere differenti,
perdiamo il privilegio
di essere liberi.*

*When we lose the right
to be different,
we lose the privilege
to be free.*

Charles Evans Hughes

MY DREAM

012

GE
L
GE



013

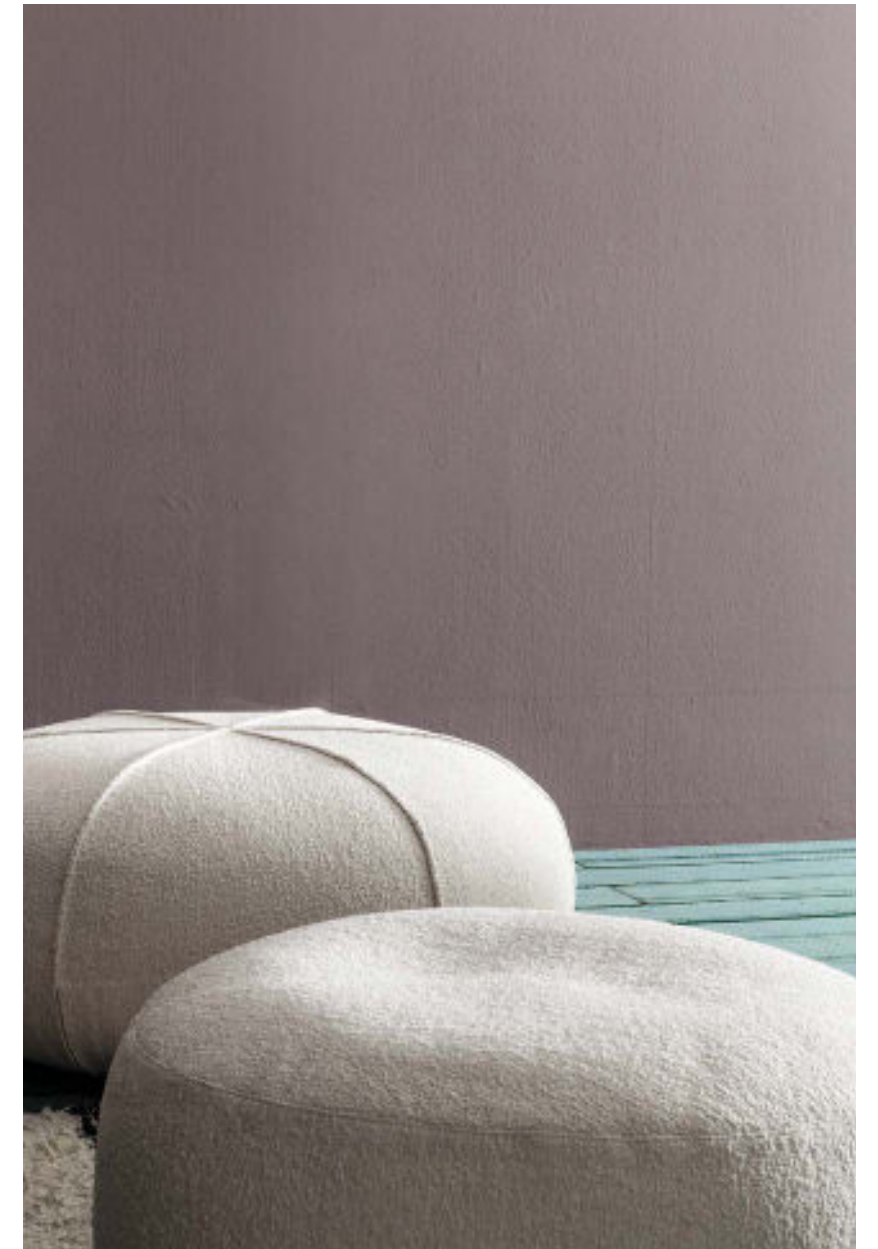

Se le forme vengono ricondotte alla loro originaria purezza, cade il confine fra estetica e funzione. Ogni dettaglio diventa l'espressione sincera dello scopo per cui l'oggetto è stato creato. Ecco perché Free ci evoca immediatamente sensazioni di benessere, comfort, libertà.

If shapes are stripped back to their original pureness, there is no boundary between aesthetics and function. Every detail becomes the genuine expression of the purpose for which the object has been created. That is why Free immediately conjures up feelings of well-being, comfort and freedom in us.

Free è libero di nome e di fatto,
ma i suoi componenti sono inappuntabili.
L'imbottitura combina supporti a molleggio
e poliuretano a quote differenziate, per offrire
una piacevole sensazione di comfort;
i rivestimenti sono di alta categoria,
come nella tradizione Twils Lounge.
Sentitevi liberi di comporre il vostro Free.

*Free by name and free by nature,
but with flawless elements.
The padding is a combination of springs
and polyurethane of different densities to ensure
a pleasant sensation of comfort;
the upholstery is top-of-the-range,
as is to be expected from Twils Lounge.
Feel free to compose your Free.*

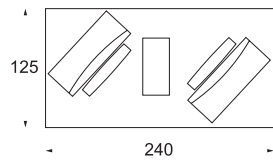

014

LS
GE



015

016

LS
GE

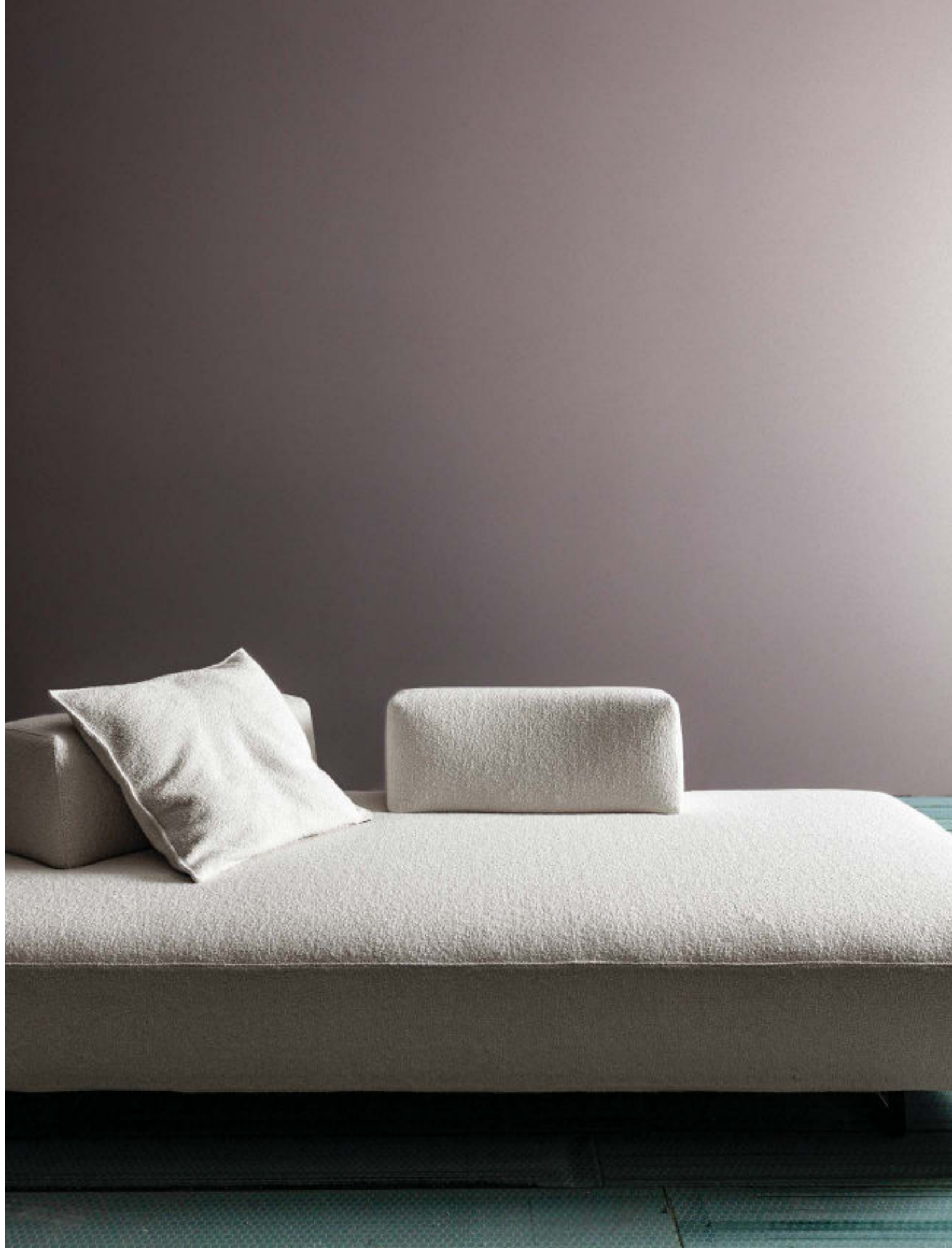

Cat. K Art. D61/001



017

Progettando Free, abbiamo pensato di creare un sistema di sedute dalla forma pura, dalla personalità trasparente, dalla componibilità facile, dall'aspetto contemporaneo. Un divano libero dedicato alle persone libere.

When we designed Free, we wanted to create a sofa whose shape was pure, whose personality was transparent, whose configuration was easy and whose appearance was contemporary. A free sofa for free people.

018

CHANGE

THINK DIFFERENT

CHANGE

Un sistema di sedute destrutturato e libero, sempre pronto a conformarsi o a variare, assecondando ogni nostra trasformazione.

A free, unstructured sofa that is always ready to conform or change, satisfying our every transformation.



Name sofa:
Free
~
Design:
R&D Twils
~
Shoot:
Free symmetries

019

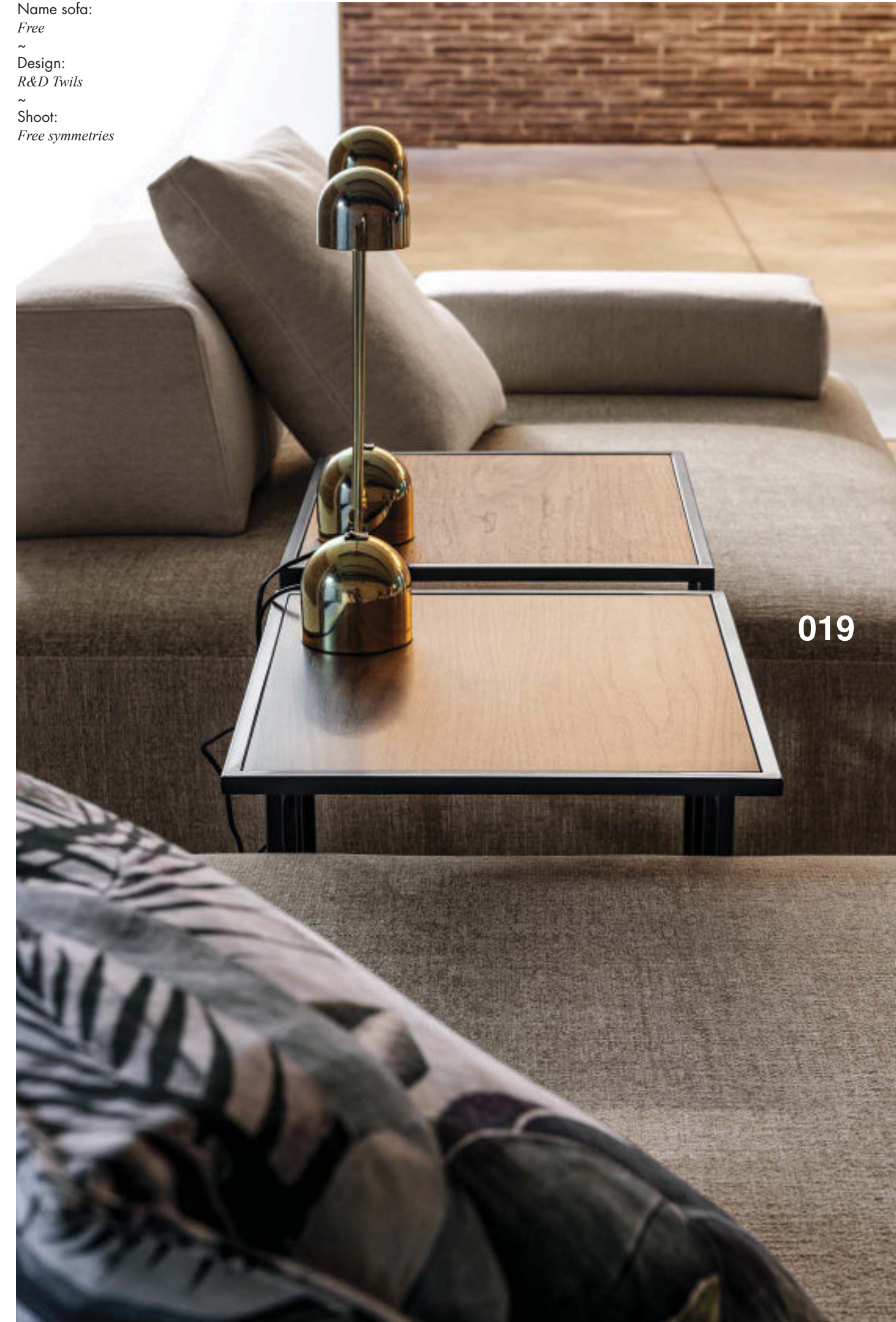

020

LINEA
GE



I singoli elementi possono essere
assemblati con grande libertà compositiva,
secondo l'esigenza, la dimensione
dell'ambiente e il gusto personale.
La linearità assoluta del design rende
Free adatto all'accostamento con accessori
e complementi di ogni epoca e stile.

*The individual elements can be
assembled with total freedom of
expression, according to our needs,
the size of the room and our personal taste.
The pure linearity of the design means
Free can be combined with accessories
of any period or style.*

021

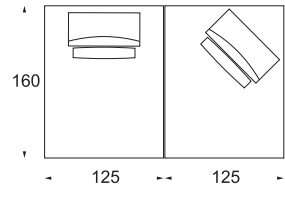

Cat. K Art. D19/005

Cat. K Art. C73/001



022

GESE
L5

La forma di Free e le sue ampie sedute rappresentano un dichiarato invito al comfort. Accostando gli elementi si possono ottenere configurazioni che lasciano ampissimo spazio al relax, quando la convivialità cede il testimone ai momenti di introspezione, riposo, distensione. Siamo noi a stabilire quando, dove e come. Free ci asseconda.

The shape of Free and its generous seating are a clear invitation to comfort. By mixing and matching the elements, we can create configurations that are perfect for relaxation, when the company of friends gives way to moments of introspection, rest, peace and quiet. It's up to us to decide when, where and how. Free will always indulge us.

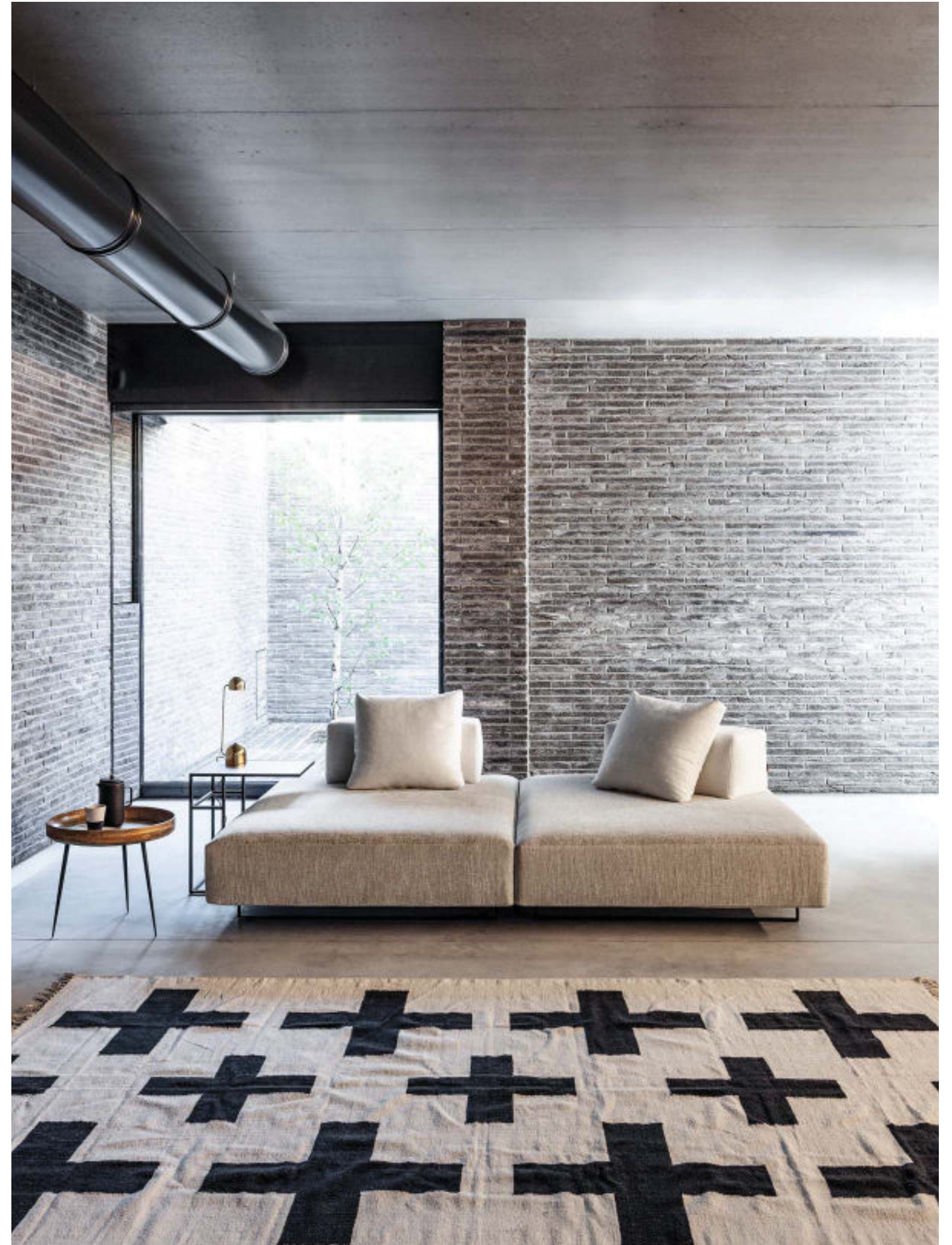
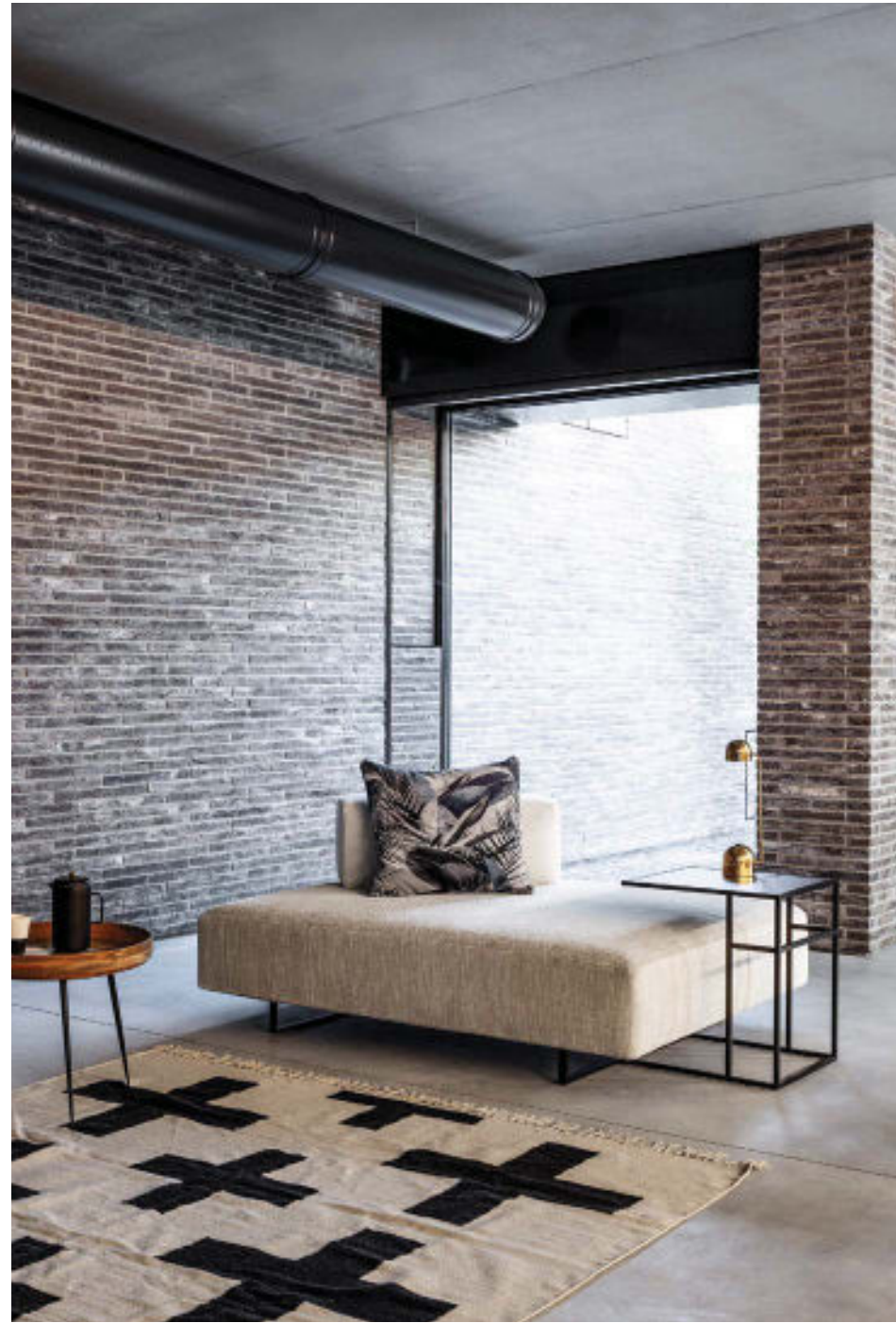

023

DO WHAT YOU LOVE

*La vita non è trovare sé stessi.
La vita è creare sé stessi.*

*Life isn't about finding yourself.
Life is about creating yourself.*

George Bernard Shaw



024

Name sofa:
Free

~
Design:
R&D Twils

~
Shoot:
Unusual perspectives

5
2
GE



025



Free si esprime al meglio nelle configurazioni ampie e articolate, che mettono in risalto la purezza delle linee. Gli elementi angolari di forma trapezoidale consentono di comporre e scomporre creativamente il divano con un semplice accostamento delle sedute, degli schienali e dei braccioli.

Free really shines in large, structured configurations which accentuate its pure lines. The trapezium-shaped corner elements allow you to creatively configure and reconfigure the sofa by just moving the seats, backrests and armrests.

I volumi monolitici e composti, la seduta ampia, gli schienali e i braccioli solidi e squadrati, a posizionamento libero: sono queste le caratteristiche che rendono Free indiscutibilmente cosmopolita e contemporaneo. Uno stile nuovo, eclettico e creativo, con la dovuta attenzione alle qualità intrinseche del prodotto, ai materiali, all'ergonomia, nel rispetto della migliore tradizione Twils Lounge.

Monolithic composed volumes, wide seats, solid square backrests and armrests which can be placed in any position: these are the features which make Free undeniably cosmopolitan and contemporary. A new eclectic and creative style where due attention is paid to the intrinsic qualities of the product, the materials and ergonomics, in the best Twils Lounge tradition.



026

GE
L
L
GE

027

028

LS
CZ
GE



Cat. K Art. C74/003



029

THE BEST IS YET TO COME

STEP BY STEP

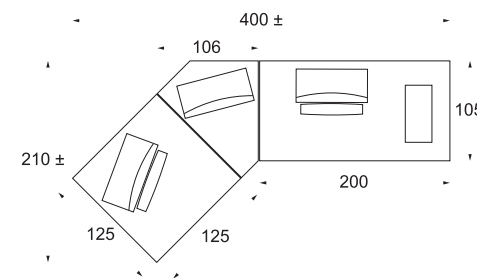

Free si presta alla strutturazione di ampie configurazioni angolari, belle da qualunque punto d'osservazione grazie alla purezza delle forme. L'impronta soft lo rende invitante, l'equilibrio dei volumi gli conferisce eleganza, la vista d'insieme è sempre armoniosa.

Free is ideal for large-scale corner configurations which look beautiful whatever angle you observe them from, thanks to the pure shapes. The soft effect makes it inviting, the well-proportioned volumes give it elegance, the overall effect is always harmonious.

030

LCN
GE

Name sofa:
Free

Design:
R&D Twils

Il sistema si compone di numerosi elementi, per assecondare qualunque esigenza di spazio, stile e configurazione. Le innovative sedute d'angolo permettono di creare forme insolite, che favoriscono la convivialità e personalizzano l'ambiente.

The range features numerous elements to satisfy all space, style and configuration needs. The innovative corner seats create unusual shapes which are great for entertaining and personalising the room.

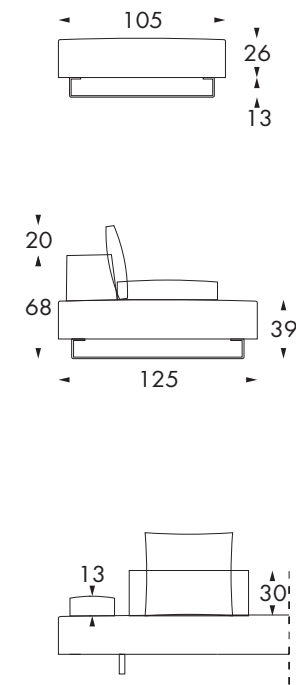

SEDUTE
Seats

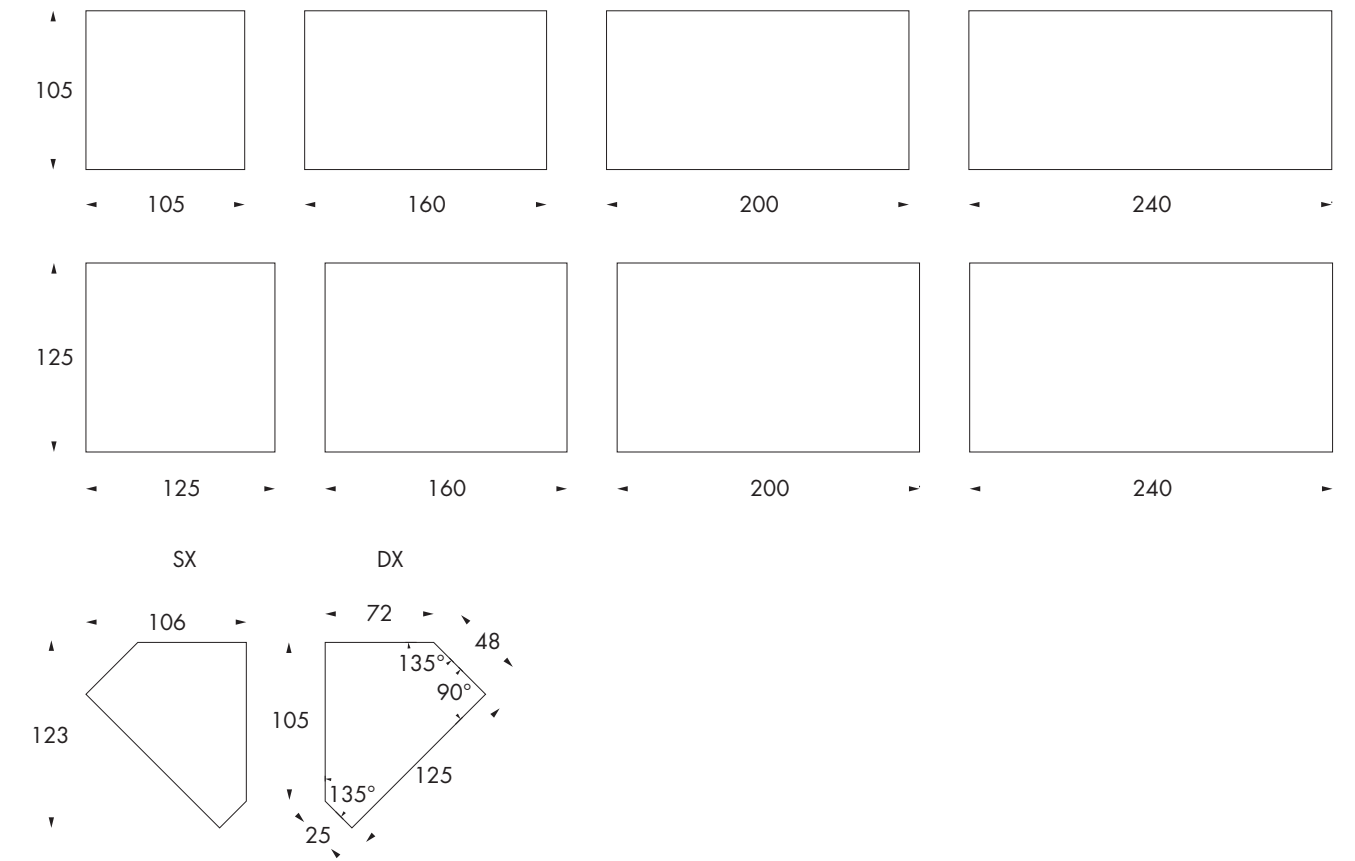

BASE SCHIENALE
Backrest

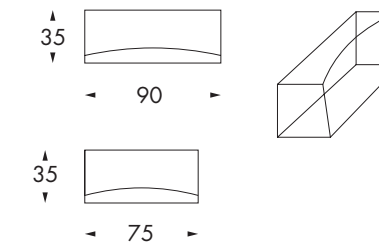

CUSCINO SCHIENALE QUADRATO
Squared backrest cushion
55x55



031

BRACCIOLO APPOGGIO
Armrest

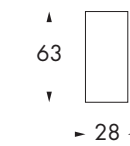

CUSCINO SCHIENALE SAPONETTA
Simple backrest cushion
55x55



SHARE

everything

Il living contemporaneo è aperto alla vita, alla luce, alla convivialità. È ospitale, sempre in evoluzione, espressivo. Un ambiente informale in cui essere a nostro agio, da soli e con gli altri, da arredare con mobili e complementi flessibili, che scegliamo per comporre il nostro personalissimo ambiente relax. Share, per condividere tutto questo.

Contemporary living spaces are open to life, light and entertainment. They are inviting, constantly evolving, expressive. An informal environment where we can feel at ease, alone or with others, a space we can fill with flexible furniture and accessories which we choose to create our very personal relaxing space. Share is all this.



Name sofa:
Share
~
Design:
R&D Twils

034

CHANGE



REVOLUTIONARY SHAPES

CHANGE

Non siamo noi che dobbiamo adattarci alla forma del divano, è lui che asseconda il nostro comfort, ci coccola, ci sostiene.

It's not us who have to adapt to the shape of the sofa, It's the sofa that indulges us, pampers us and supports us.

035

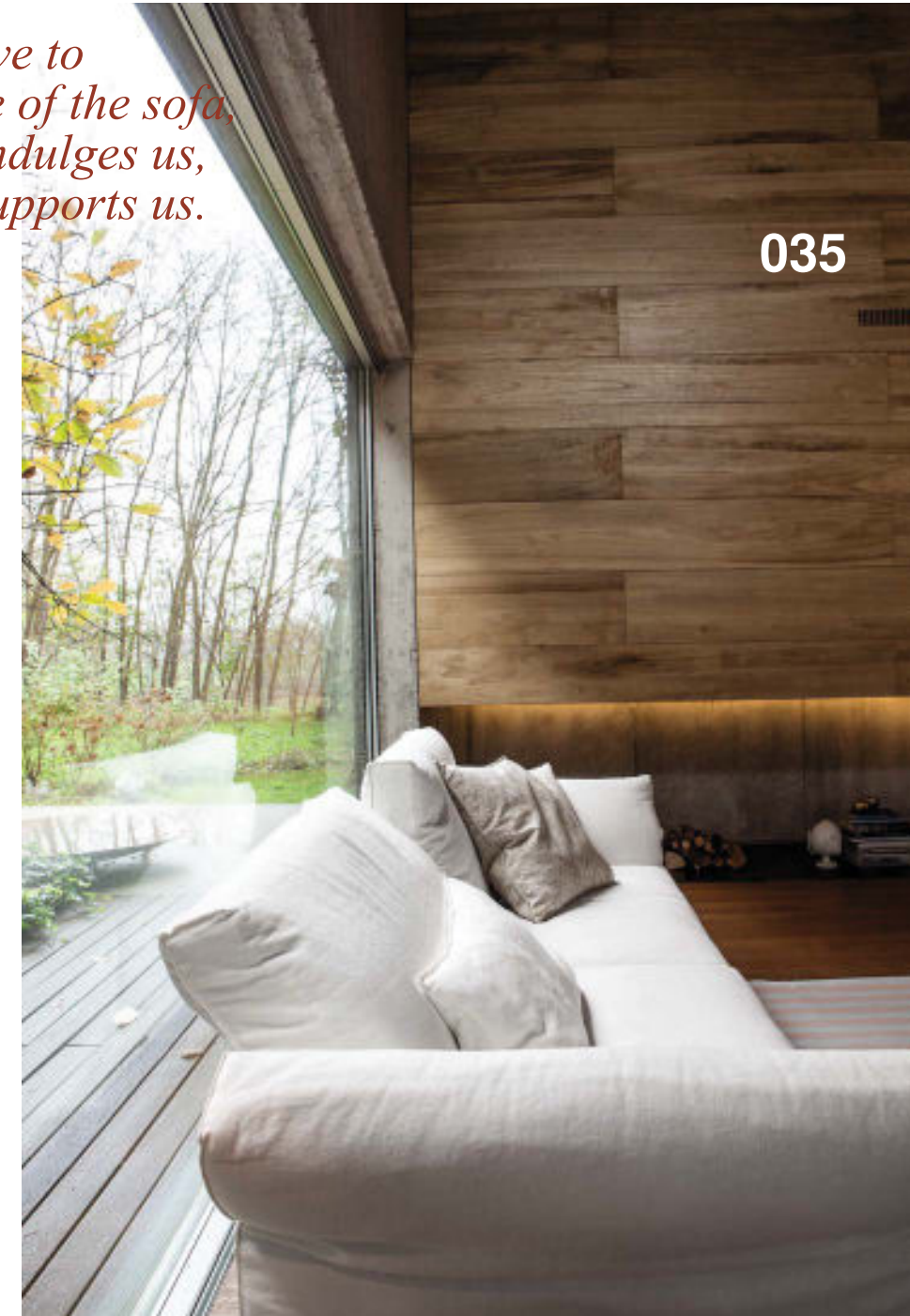

Name sofa:
Share
~
Design:
R&D Twils
~
Shoot:
Rays of light

036

LINEA
GE



Quando si pensa a un divano,
si pensa a qualcosa di statico e inerte.
Share sovverte questa convinzione,
perché nello schienale e nei braccioli
nasconde un meccanismo che lo rende
snodabile e consente di disarticolarlo
dandogli la forma che in quel momento
desideriamo. Una piccola rivoluzione.

*When you think of a sofa,
you think of something static and inert.
Share turns this concept on its head
because a mechanism is concealed in
its backrest and armrests which allows
you to adjust their shape and position,
giving them the form you want at that
particular moment. A little revolution.*

037

Cat. Must Art. A64/001

Cat. K Art. D19/005

038

GEZE



Share has an essential design with narrow volumes and clean, crisp lines. We choose how to configure it, transforming it to our whim. It will adapt, effortlessly taking on the shapes we decide, because our comfort is its priority. Share, soft on the outside and soft in its heart.



Share ha un design rigoroso, fatto di volumi sottili e profili netti. Siamo noi a configurarlo, trasformandolo a seconda della nostra propensione. Lui si adatterà assumendo fluidamente le forme stabilite, perché il nostro comfort è la sua priorità. Share, morbido fuori e morbido nel cuore.



*Sii felice per questo momento.
Questo momento è la tua vita.*

*Be happy for this moment.
This moment is your life.*

Omar Khayyam

039

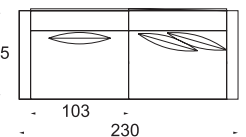

Name sofa:
Share
~
Design:
R&D Twils
~
Shoot:
Everything changes

040

LINEA

LET LIFE SURPRISE YOU

IMAGINE

*La logica ti porterà dalla A alla B.
L'immaginazione ti porterà ovunque.*

*Logic will get you from A to B.
Imagination will take you everywhere.*

Albert Einstein



I vari elementi del sistema, che comprende anche una rilassante chaise longue, possono essere liberamente composti per creare la nostra temporanea oasi di relax. Effimera perché potremo modificarla a nostro piacimento, con un semplice gesto.

The different elements in the system, which also includes a relaxing chaise longue, can be freely mixed and matched to create our temporary haven of relaxation. It is ephemeral because, with one simple action, we can change it to suit our mood.

041

Cat. Must Art. D24/006



042

GEZE



043

044

SHARE



Siamo tutti diversi, e ognuno di noi ha una posizione preferita per i momenti di relax. Con Share è possibile regolare l'inclinazione sia dello schienale che dei braccioli, conformandola alla nostra comodità. E con un semplice gesto, tutto torna come prima.

We're all different, we all have a favourite position when we relax. With Share you can adjust the inclination of both the backrest and the armrests, choosing the most comfortable position for you. And, with one simple action, everything goes back to how it was.

*If you never try,
you'll never know.*

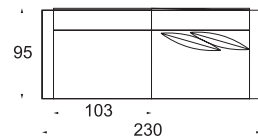

045



Name sofa:
Share
~
Design:
R&D Twils
~
Shoot:
We are not all the same

EVERY MOMENT MATTERS

*Solo io posso cambiare la mia vita.
Nessuno può farlo per me.*

*Only I can change my life.
No one can do it for me.*

Carol Burnett

La comodissima chaise longue amplifica la sensazione di comfort, ulteriormente accentuata dalla caratteristica principale di Share: la sua duttilità. La forma canonica del divano a tre posti si riduce al contorno, adesso è la nostra esigenza di comfort a plasmare il nuovo morbido profilo.

The ultra-comfortable chaise longue amplifies the sensation of comfort, which is further accentuated by the main characteristic of Share: its flexibility. The established design of the three-seater sofa is more compact along the sides here, our need for comfort shapes its new soft profile.



046

5
5
GE

047

Una base sottile sorretta da sobri piedini metallici. Cuscini morbidi e invitanti. Schienale alto e braccioli confortevoli. Proporzioni accuratamente studiate per offrirvi il giusto relax. Cosa mancava a un divano perfetto? La possibilità di modellarlo, e con Share si può.

A narrow base supported by understated metal feet. Soft, inviting cushions. High backrest and comfortable armrests. Carefully studied proportions to ensure maximum relaxation. What's missing in a perfect sofa? The chance to change its shape, and with Share you can.

Cat. K Art. D58/099



048

GE
L
S
Z
E



049

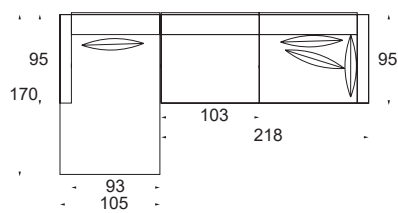



050

LS
GE

**IMAGINATION RULES
THE WORLD**
BREAK THE RULES

Gli elementi del sistema Share possono essere composti, raggruppati e distribuiti secondo le esigenze individuali e lo spazio a disposizione. Un ampio pouf quadrato, versatile complemento, può essere utilizzato come seduta alternativa o piano d'appoggio.

The elements in the Share system can be joined, grouped and arranged according to individual needs and the available space. A large square footstool, a truly versatile accessory, can be used as alternative seating or a surface to place things.

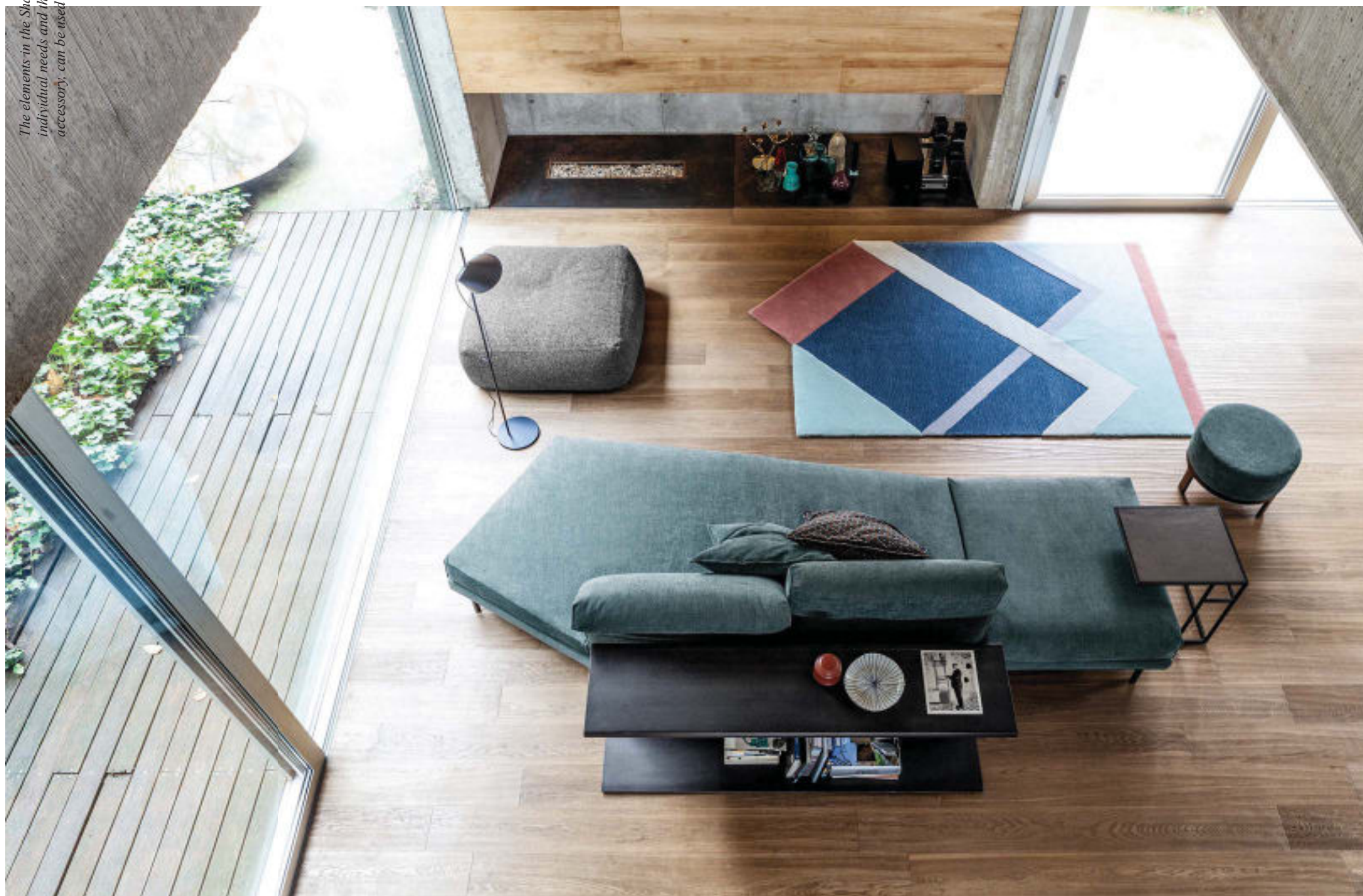

051

Name sofa:
Share
~
Design:
R&D Twils
~
Shoot:
Imagine a room

Share è adatto al posizionamento in centro stanza, requisito ormai comune a tutti i divani d'impronta contemporanea. La sua conformazione non è mai definitiva, perché ogni elemento può essere accostato o disgiunto a seconda della creatività individuale e dello spazio a disposizione. Ogni trasformazione è una nuova occasione.

Share can be positioned in the centre of the room, a criterion of all contemporary sofas. Its conformation is never definitive, because every element can be combined or separated depending on your own creativity and the available space. Every transformation presents a new opportunity.



052

GE
L5
GE

053



054

LS
CIN
GE

*Con Share la forma diventa effimera,
il comfort diventa assoluto.
Una nuova interpretazione del divano,
contemporanea e cosmopolita.*

*With Share the shape becomes ephemeral,
our comfort total.
A new take on the contemporary,
cosmopolitan sofa.*

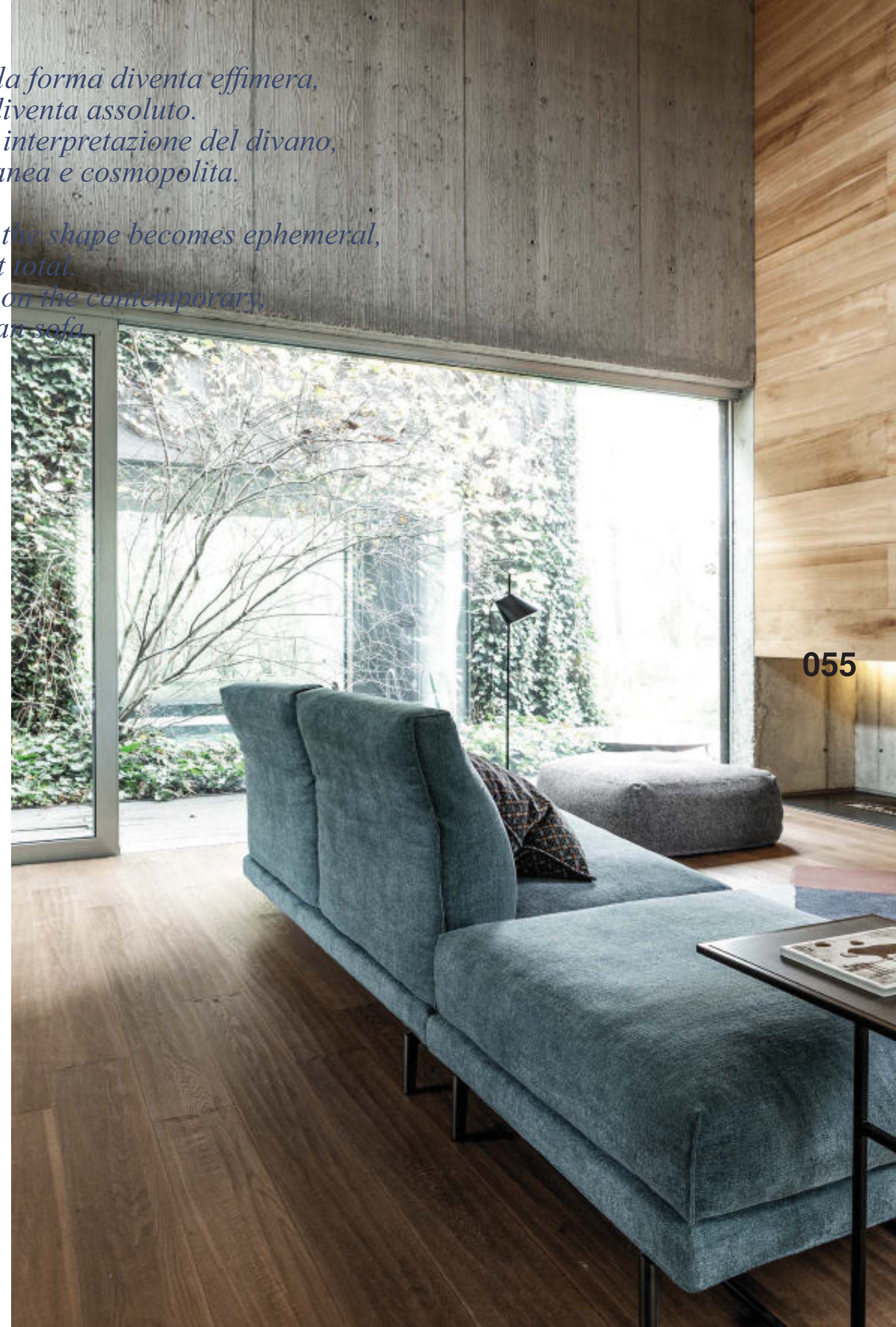

055

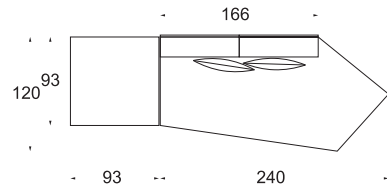

C'era una volta il salotto, quello dove si richiedeva di "stare composti" e che era "composto" anch'esso, secondo le convenzioni dettate dal bon ton. Share propone un nuovo paradigma, basato sulla libertà, e sulla flessibilità. Un salotto che possiamo scomporre e ricomporre, modificare nella forma, adattare al nuovo mondo dinamico e condiviso.

Once upon a time there was a living room where you had to "sit nicely" and which was also "nice" itself, according to the conventions dictated by good manners. Share proposes a new concept, based on freedom and flexibility. A living room we can configure and reconfigure, whose shape we can change, which we can adapt to our new dynamic and shared world.

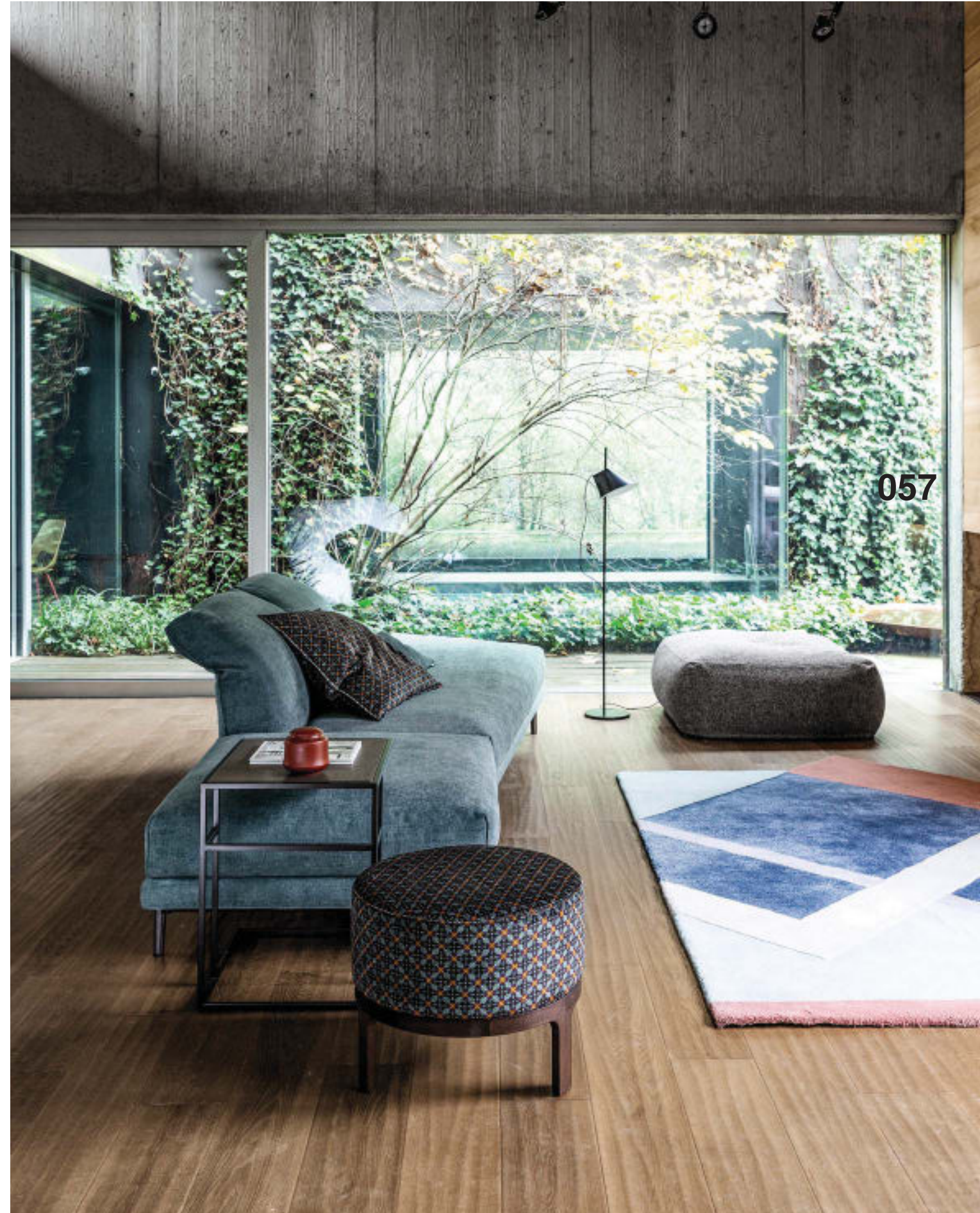

*Si vede bene solo con il cuore.
L'essenziale è invisibile agli occhi.*

*One sees well only with the heart.
The essential is invisible to the eyes.*

Antoine de Saint-Exupéry

Siamo per la spontaneità, per la luce,
per il comfort. Siamo per la libera scelta,
per le cose reali, per la condivisione.
Siamo sinceri, determinati, poco inclini
ai compromessi. Siamo per Essere.

*We're all about spontaneity, light,
comfort. We're all about freedom of
choice, real things, sharing.
We are sincere, determined, not keen
on compromise. We're all about Being.*

A HOUSE IN THE WOODS



Name sofa:
Pouf Soft
~
Design:
R&D Twils
~
Shoot:
A world around

Name sofa:

Share

~

Design:

R&D Twils

~

Shoot:

Life is changing

*Vedi la semplicità nel complicato.
Raggiungi la grandezza nelle piccole cose.*

*See simplicity in the complicated.
Achieve greatness in little things.*

Anche nelle composizioni di più ampio respiro,
Share mantiene inalterato il suo aspetto leggero e informale.
Un'accogliente isola che contiene gli spazi per il relax, il tempo libero,
l'incontro e la convivialità. Un divano da vivere 24/7,
rendendo sempre più impercettibile il confine
fra gli spazi di casa, ormai fluidi e comunicanti.

*Even in large-scale compositions, Share is still light and
informal. A welcoming island offering space for relaxation,
free time, getting together and entertaining. A sofa for 24/7 living,
blurring the line between the flowing and communicating
spaces in the home even more.*



060

CS
GE

061



062

GE
L
S
E

L'estetica di Share si esprime al meglio nelle grandi composizioni angolari, che invitano alla convivialità e al relax. Visivamente, la base sottile crea continuità e valorizza la morbidezza degli ampi cuscini della seduta. Gli alti schienali e i braccioli assecondano la forma attribuita.

Share looks its very best in large corner compositions, which invite you to sit back and relax with friends. Visually, the slender base creates continuity and complements the large soft seat cushions. The high backrests and armrests enhance the shape.



Anche un viaggio di mille miglia inizia con un singolo passo.

The journey of a thousand miles begins with one step.

Lao Tzu

063

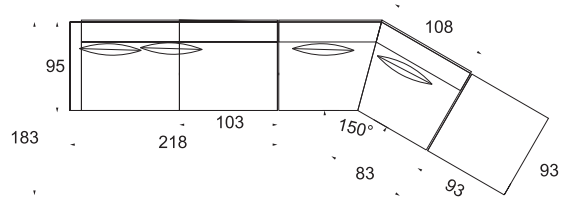

THE IMPORTANCE OF INNOVATION

FIND OUT

In ogni momento la composizione può essere integrata con l'aggiunta di nuovi elementi. Se la casa diventa più spaziosa, se gli amici aumentano, se vogliamo che lo spazio del comfort diventi ancora più ampio. Share è sempre incline all'innovazione.

New elements can be added to the composition at any time. If your house gains extra space, if the number of your friends grows, if you want more space for your own personal comfort. Share always welcomes innovation.

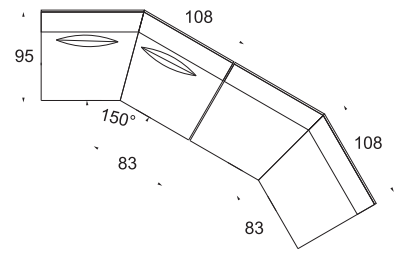

La grande composizione angolare può essere assemblata secondo lo spazio disponibile e il numero di posti desiderato. Il pouf può essere inserito come elemento terminale, oppure posizionato liberamente come seduta aggiuntiva o comoda base d'appoggio.

The large corner composition can be assembled according to the available space and the number of places desired. The footstool can be added as an end element or can be placed wherever you want as an additional seat or handy surface to put things on.

064

LS
GE



065

066

CS
GE

Name sofa:
Share

Design:
R&D Twils

La varietà di formati degli elementi seduta, comprensivi di laterali e mèridienne, agevola le configurazioni di ampio respiro. Share è un divano creativo, nuovo di spirito e concezione.

The seating comes in a variety of different shapes and sizes, including side elements and a dormeuse, making it easier to design large-scale compositions. Share is a creative sofa, with a new spirit and concept.

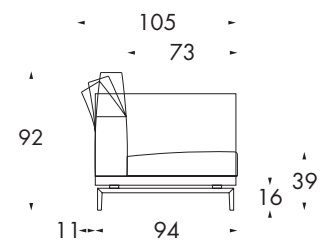
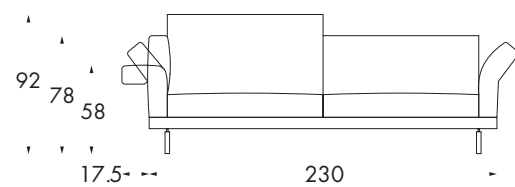

DIVANI
Sofas

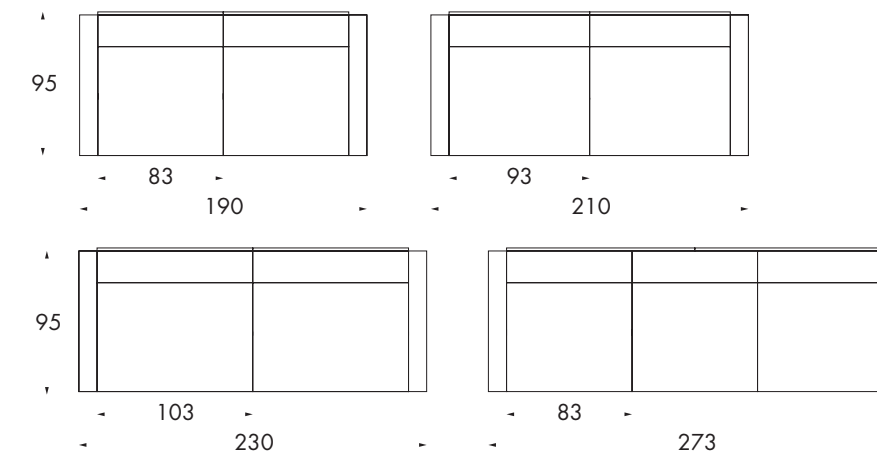

LATERALI SX
Side elements - LH



LATERALI DX
Side elements - RH

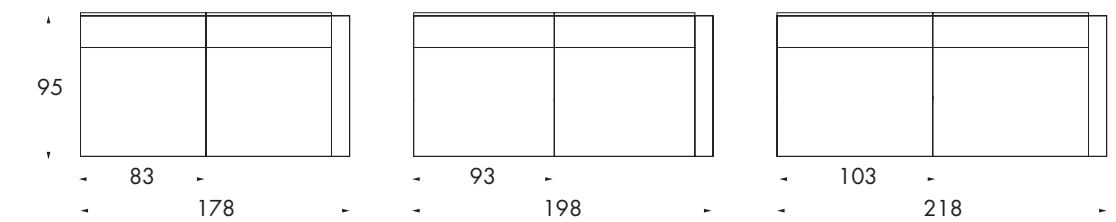

MERIDIENNE SX DX
Dormeuse - LH or RH

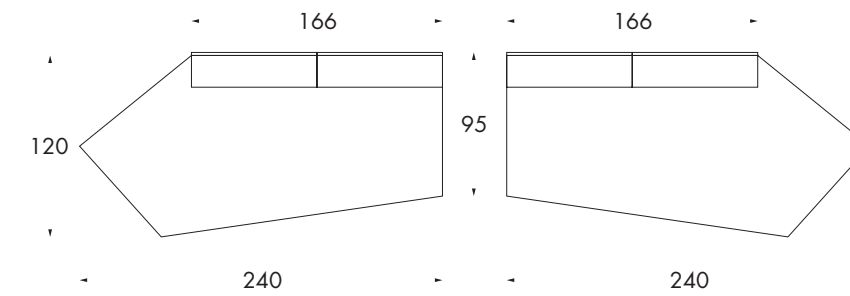

ELEMENTO TRAPEZIO
Corner element - 150°

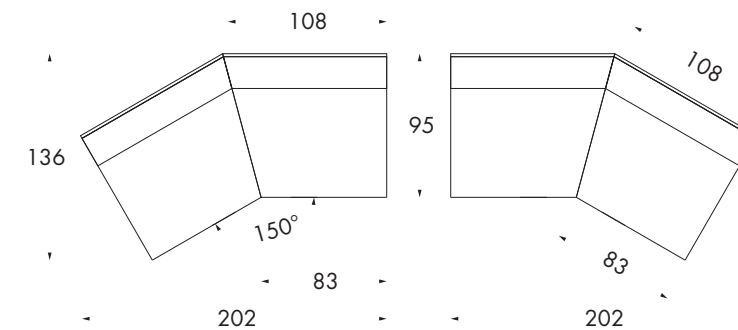

PENISOLA SX DX
Chaise Longue - LH or RH

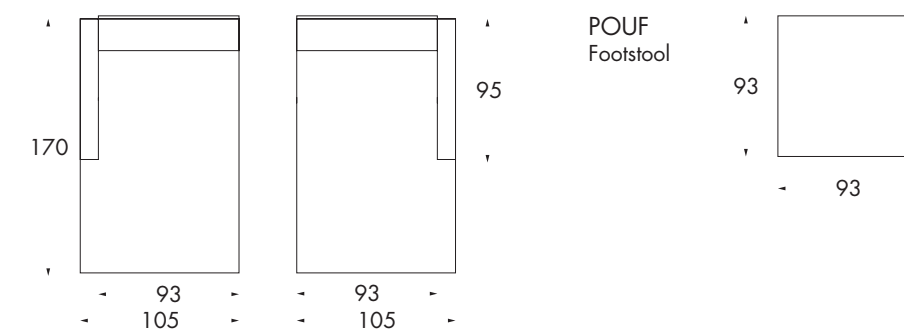

067

Twils Lounge: collezioni fortemente connotate che ambiscono a rappresentare una nuova filosofia dell'abitare, anche attraverso la riconosciuta qualità e dovizia di materiali e combinazioni tessili che rendono unico il nostro brand. Un mondo di ottimo design, stile esclusivo e comfort assoluto.

Twils Lounge: highly individual collections designed to represent a new philosophy of the living space which feature the trademark quality and wealth of materials and fabric combinations that make our brand so unique. A world of outstanding design, exclusive style and guaranteed comfort.

068

L
G
E

Balmoral



069

Name sofa:
Balmoral
~
Design:
Cairoli & Donzelli

Name sofa:
Balmoral
~
Design:
Cairoli & Donzelli
~
Shoot:
Respect the rules

070

DESIGN

MY LIFE IS MY ART

GREAT SKILL

*Fallo con passione
o non farlo affatto.*

*Do it with passion
or not at all.*

Ralph Emerson

In Balmoral convive qualcosa di familiare e qualcosa di innovativo. Ci risultano familiari le sue linee, squisitamente seventy, e le sue proporzioni accoglienti e generose. Sono innovative la sua grande componibilità, la pulizia dei contorni, l'accuratezza dei dettagli: requisiti di un grande classico contemporaneo.

There is something familiar yet innovative about Balmoral. Its exquisitely Seventies lines and generous, welcoming proportions appear familiar. Its exceptional modularity, clean lines and attention to detail are innovative: the essential features of a great contemporary classic.

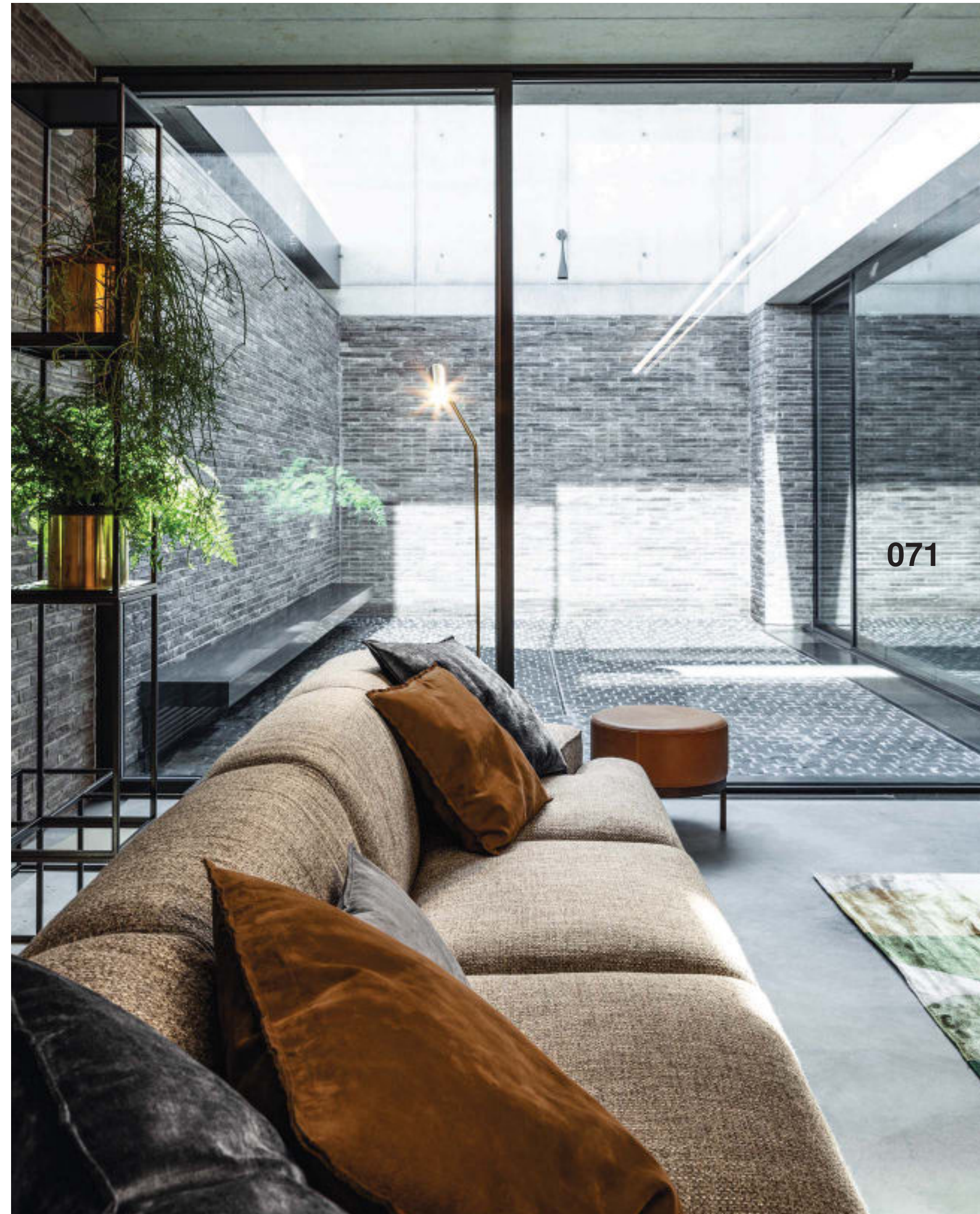

072

UNGE



Cat. Must Art. D59/002



073



074

GENE

Attratti dal suo aspetto invitante ci sediamo,
 e scopriamo che il valore aggiunto consiste
 nella sua avvolgente comodità, dovuta a due strati
 di poliuretano di differente densità che lo rendono
 assolutamente confortevole anche in assenza
 di elementi di molleggio. È questa la dote nascosta.

*Its appearance is irresistible, so we sit down
 and discover that its added value is precisely
 its embracing comfort: two layers of polyurethane
 of differing density which ensure maximum
 comfort even without springs.
 This is its hidden secret.*

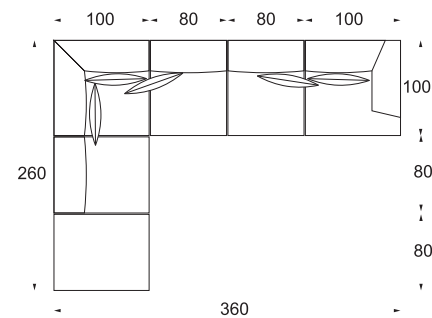

075



Name sofa:
Balmoral

Design:
Cairolì & Donzelli

Shoot:
Forget the rules

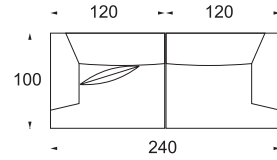

*Se obbedisci alle regole,
ti perdi tutto il divertimento.*

*If you obey all the rules,
you miss all the fun.*

Katharine Hepburn

Il design può sperimentare forme inedite, oppure reinterpretare le forme e gli stili classici riformulando i dettagli e le proporzioni. Un esercizio di stile che abbiamo applicato a Balmoral: braccioli e schienali ampi, cuscini privi di cuciture sull'angolo frontale per accentuare la morbidezza, volumi importanti ma armonici.

Design can experiment with innovative shapes or reinterpret classic shapes and styles and give them new details and proportions. This process has been applied to Balmoral: large armrests and backrests, cushions without stitching on the front corner to accentuate the softness, large but harmonious volumes.





078

LINEA
GE

079

Name sofa:
Balmoral
~
Design:
Cairoli & Donzelli
~
Shoot:
The rules of attraction

La morbidezza di Balmoral è accentuata dall'assenza di angoli acuti; il morbido contorno degli schienali e delle sedute è una promessa di comfort che sarà mantenuta. Molto più di un divano: una vera oasi di comfort.

The softness of Balmoral is accentuated by the absence of acute angles; the soft profile of the backrests and seats is a promise of comfort that will be kept. So much more than a sofa: a haven of comfort.

080

LS
GE



*Non dimenticare mai chi sei.
Never forget who you are.*

Il sistema prevede diverse larghezze dell'elemento base per una componibilità flessibile, sempre di ampio respiro. Le cuciture tracciano i profili, sfuggente richiamo allo stile borghese che è la cifra dell'eleganza.

The basic element in this range is available in different widths, offering flexibility and variety when creating compositions. The stitching outlines the profiles, an elusive nod to the conservative style which gives it its elegance.

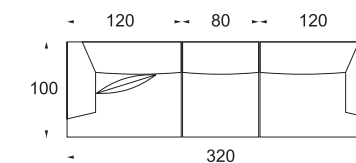

082

5
2
GE



Nella composizione simmetrica, con due ampi elementi uniti al centro da uno di dimensioni più contenute, risalta la cifra stilistica che contraddistingue Balmoral: la compostezza dell'armonia. Gli ampi braccioli innestati sulla seduta si fondono alla morbidezza dello schienale.

The symmetrical composition, with two large elements joined in the middle by a smaller element, embodies the signature style of Balmoral: composed harmony. The wide armrests inserted into the seat merge with the soft backrest.

083

*Vivi ciò che ami.
Live what you love.*

Balmoral è valorizzato dai rivestimenti monocromatici e impalpabilmente materici. L'ampia gamma offerta da Twils Lounge consente la massima personalizzazione, per uno stile che non tramonta.

Balmoral is enhanced by the plain colour and imperceptible texture of the upholstery. The wide range of upholstery in the Twils Lounge Collection allows for maximum personalisation, for a style that never goes out of fashion.



Name sofa:
Balmoral

Design:
Cairolì & Donzelli

Stile contemporaneo, impronta soft:
Balmoral si presta alla strutturazione di ampie
configurazioni, belle da qualunque punto
d'osservazione grazie alla purezza delle forme.

*Contemporary style, soft effect:
Balmoral is ideal for large-scale compositions
which look beautiful from whatever
angle you observe them,
thanks to their pure shapes.*

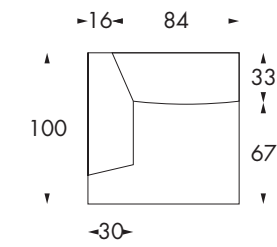
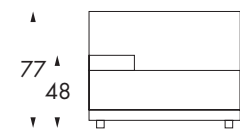
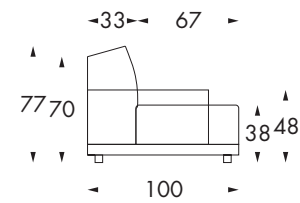

LATERALI SX
Side elements - LH

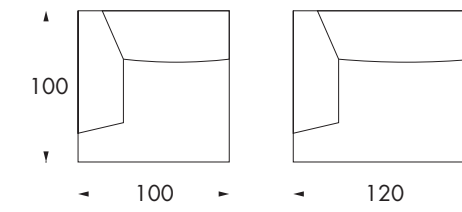

LATERALI DX
Side elements - RH

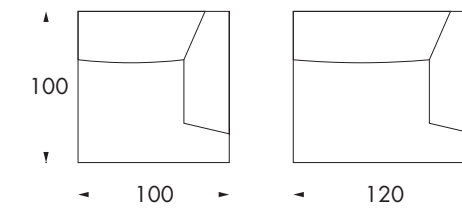

CENTRALI
Central elements

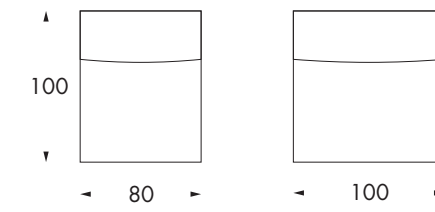

ANGOLARE
Corner element

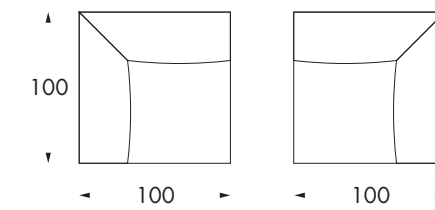

POUF
Footstools

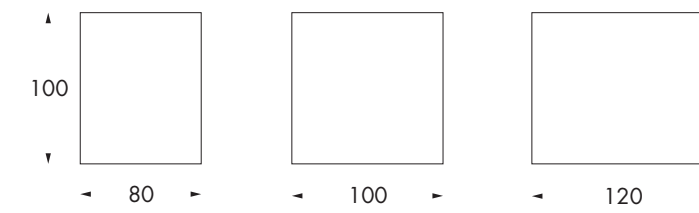

L'ambiente casa è un habitat complesso, che si fonda sull'equilibrio fra i vari elementi. Ogni nuovo inserimento dovrà essere in armonia con l'esistente, valorizzarlo, creare continuità.

Tutti i modelli Twils Lounge sono accoglienti, generosi, morbidi a prescindere dalla forma e dal tratto. Un esercizio di stile perfettamente riuscito.

The home is a complex habitat, a delicate balance of different elements. Every new piece must blend in with the rest, enhance it, create continuity.

All the models in the Twils Lounge collections are welcoming, generous and soft irrespective of their shape or design. A truly successful exercise in style.



OPEN

Name sofa:
Open
~
Design:
R&D Twils

090

CS
GE



Name sofa:
Open
 ~
 Design:
R&D Twils
 ~
 Shoot:
Reality and fantasy

Nelle case contemporanee il living è diventato lo spazio della condivisione, della convivialità e della connessione. I nuovi sistemi di sedute devono adeguarsi a queste rinnovate esigenze, diventare eclettici, flessibili, multitasking.

In modern-day homes, the living area has become a space for sharing, entertaining and connecting. New seating systems have to adjust to these latest needs, become eclectic, flexible, multitasking.

LIFE OF THE PARTY

ENJOY

Raramente la fantasia è una fuga dalla realtà. È piuttosto un modo per comprenderla.

Fantasy is hardly an escape from reality. It's a way of understanding it.

Lloyd Alexander

091



Con le sue misure generose e gli elementi che possono essere composti a piacimento, Open asseconda la continua evoluzione della vita contemporanea. Ha forme essenziali e morbide, e le proporzioni di ogni modulo che compone il sistema sono accuratamente studiate per offrirvi il comfort che aspettiamo.

With its generous proportions and elements that can be grouped however you want, Open indulges the continuous evolution of contemporary life. It has soft, essential shapes and the proportions of each module in the range are carefully studied to deliver the comfort we expect.

092

LS
GE



093



094

GE
L5
C2

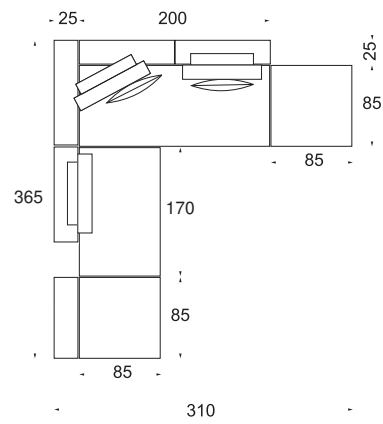

095



Cat. Must Art. D65/013

Open è dinamico e multiforme. Può essere configurato in ragione dello spazio disponibile, delle effettive esigenze e del gusto individuale. Gli eleganti rollò sullo schienale aggiungono stile e sostegno; i grandi e soffici cuscini possono essere liberamente disposti, favorendo il nostro relax.

Open is dynamic and versatile. It can be configured according to the available space, our actual needs and individual taste. The elegant roll cushions on the backrest add style and support; the large, soft cushions can be arranged however you want for maximum relaxation.

QUALITY TIME

COMPANY

*Stare con te o stare senza di te
è l'unico modo che ho
per misurare il tempo.*

*Being with you or being
without you is the only way
I can measure time.*

Jorge Luis Borges

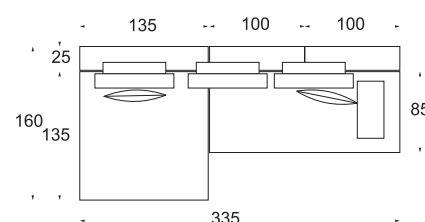

Name sofa:
Open
~
Design:
R&D Twils
~
Shoot:
Never alone again

L'ampissimo campionario di tessuti
proposto da Twils Lounge consente
di personalizzare lo stile, anche accostando
trame, cromie e matericità differenti.
Componibilità e creatività: con Open
il living sarà il palcoscenico del vostro stile.

*The extensive Twils Lounge fabric selection
allows you to personalise the style of your
furniture by mixing and matching weaves,
colours and textures.
Modularity and creativity: with Open your living
area becomes the stage on which to showcase your style.*



096

LS
Lounge

097



Open è un sistema modulare composto da elementi proposti in diverse misure, utilizzabili sia singolarmente che accostati. Lo caratterizza il design razionale e pulito, giovane e informale, con la consueta grande attenzione che Twils Lounge rivolge ai fattori costruttivi e alla qualità intrinseca.

Open is a modular system with different-sized elements that can stand on their own or be combined with others. The design is rational, clean, young and informal and features the signature attention which Twils Lounge pays to construction and intrinsic quality.



Name sofa:
Open
~
Design:
R&D Twils
~
Shoot:
Points of view

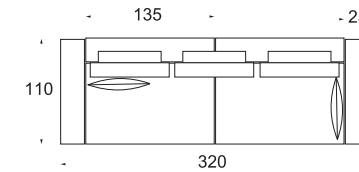

*L'immaginazione non ha età
e i sogni sono per sempre.*

*Imagination has no age
and dreams are forever.*

Walt Disney

Come per tutti i modelli Twils Lounge,
la scelta dei rivestimenti sarà determinante
per mettere a punto e personalizzare lo stile.
L'accostamento di matericità differenti
dona risalto e impreziosisce i dettagli.

*The choice of upholstery is decisive
to establish and personalise the
style of all Twils Lounge models.
Combining different textures draws
attention and enhances the details.*



Volumi monolitici e definiti, seduta ampia
resa confortevole dai cuscini e dai braccioli
solidi e squadrati: Open ha un carattere
decisamente cosmopolita e contemporaneo.

*Monolithic, defined volumes, wide seats
made even more comfortable by the solid,
square cushions: Open has a decidedly
cosmopolitan and contemporary character.*

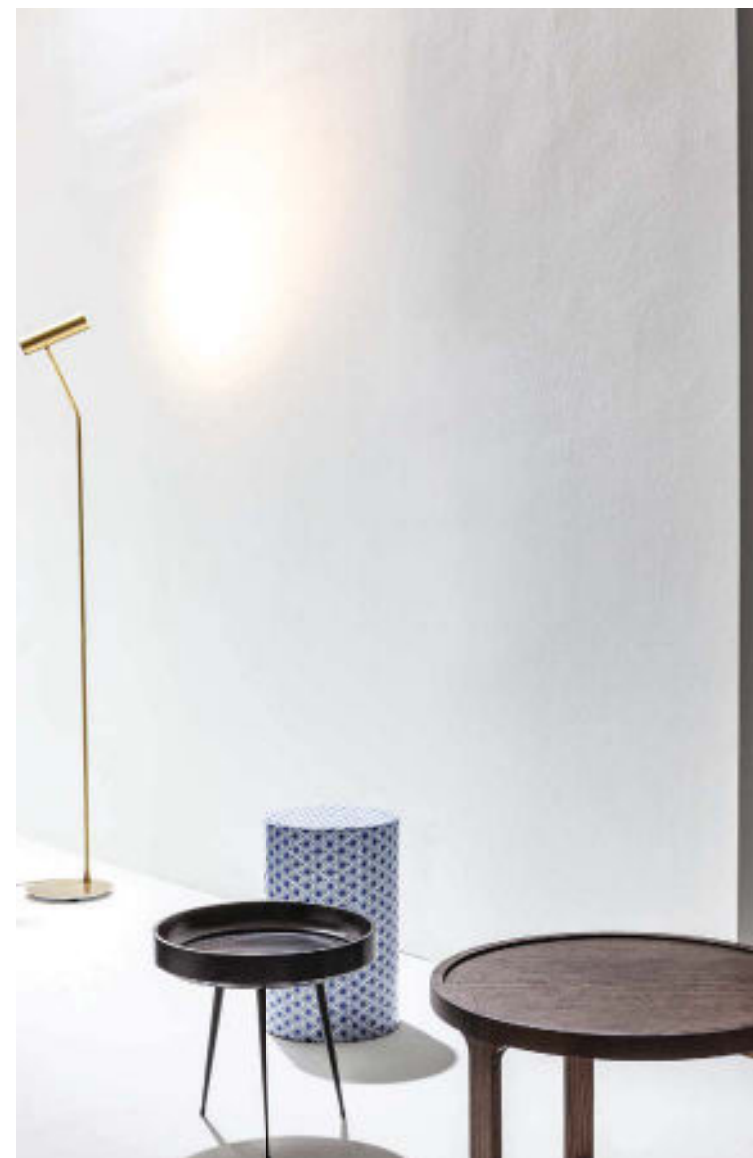

CITIZEN OF THE WORLD

ON THE GO

Un sottile cuscino trapuntato poggiato sulle sedute accentua il carattere di Open, offrendogli un'aura fashion che lo rende ancora più invitante. Nella classica configurazione simmetrica con i braccioli su entrambi i lati, Open acquisisce un aspetto più formale, mantenendo intatta la sua modernità.

A thin quilted cushion placed on the seats accentuates the character of Open, giving it fashionable appeal and making it even more inviting. In the classic symmetrical configuration with armrests on both sides, Open takes on a more formal appearance, while preserving its modernity.

Cat. K Art. C10/007

Cat. E Art. 832/428

0102

GE
L5
GE



0103

0104

LS
NGE

Name sofa:
Open

Design:
R&D Twils

Il sistema Open è composto da elementi di geometria semplice, per un design basato sullo studio accurato delle proporzioni. Possono essere disposti in innumerevoli configurazioni, a partire da due semplici sedute.

The elements in the Open range have simple geometrical shapes and carefully studied proportions. They can be arranged in a wide variety of configurations, even simply two seats.

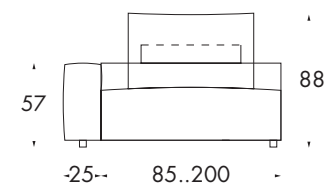
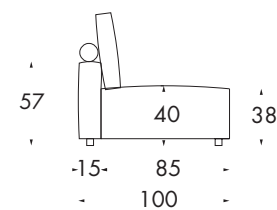
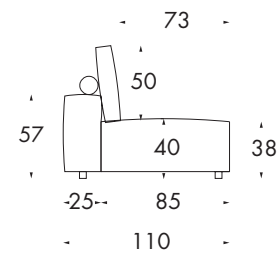

SEDUTE
Seats

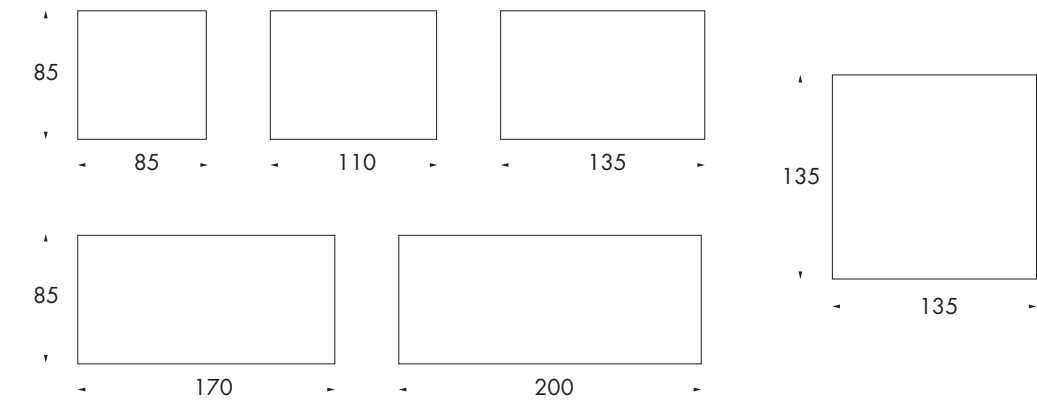

BRACCIOLI
Armrests

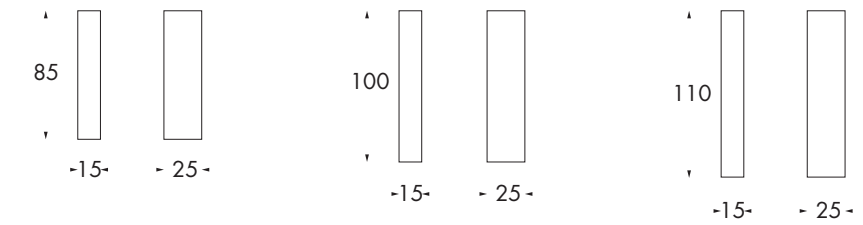

SCHIENALI
Backrests

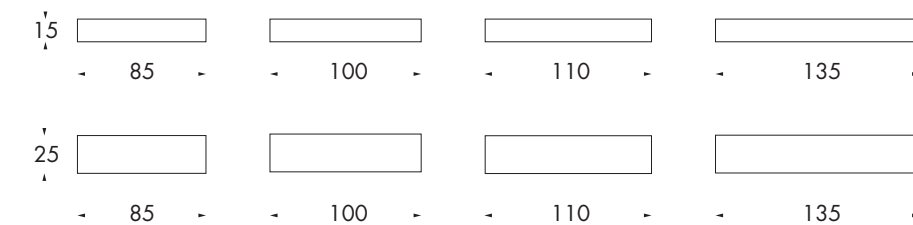

CUSCINO SCHIENALE CON ROLLO
Backrest cushion with roll

H.55



0105

ELEMENTI FREE di possibile utilizzo.
FREE suitable elements.

BASE SCHIENALE
Backrest

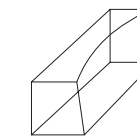
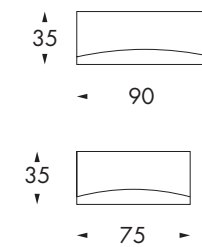

CUSCINO SCHIENALE QUADRATO
Squared backrest cushion
55x55

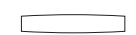

BRACCIOLO APPOGGIO
Armrest

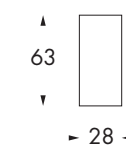

CUSCINO SCHIENALE SAPONETTA
Simple backrest cushion
55x55



*La vita non è un problema da risolvere,
ma una realtà da sperimentare.*

*Life is not a problem to be solved,
but a reality to be experienced.*

Søren Kierkegaard

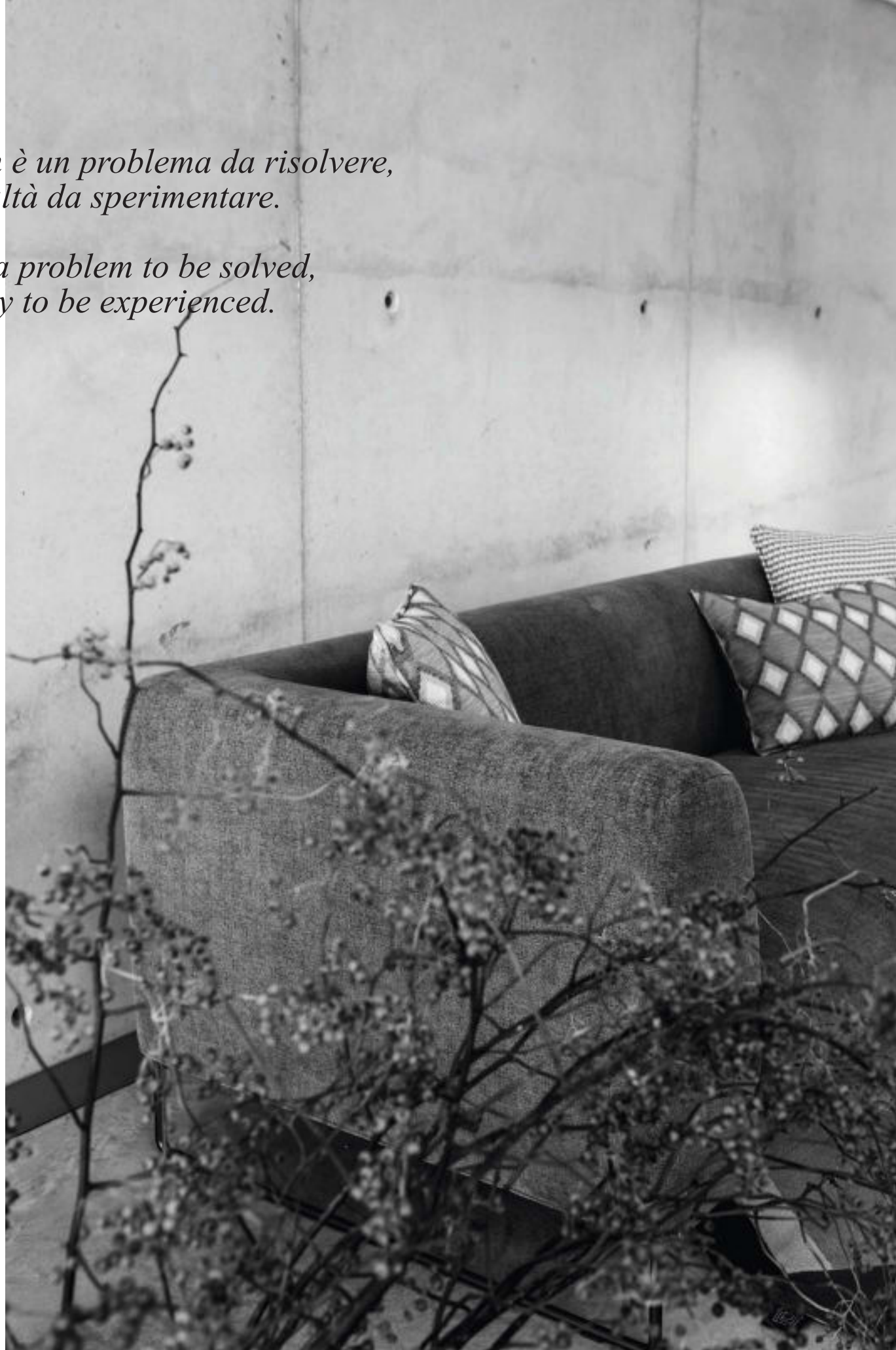

Name sofa:

èS.

~

Design:

R&D Twils

èS.

èS. è il sistema componibile che racchiude l'essenza dello stile Twils Lounge. Il nostro modo di interpretare il design, il nostro quotidiano impegno di esserci.

èS. is the modular range that defines the very essence of the Twils Lounge style. Our way of interpreting design, our daily commitment to being there.

0106

LS
GE

0107



0108

GE
L5
GE

Name sofa:
èS.
~
Design:
R&D Twils
~
Shoot:
Surfaces and patterns

TO BE ABOUT TO BE

LIFE

èS. è il divano basato sull'essere. Un sistema componibile di elementi contemporaneo, confortevole e attraente, studiato nelle proporzioni e nei dettagli, frutto di una ricerca volta a coniugare lo stile con la sostanza. L'ampia e profonda seduta è resa ancora più comoda da uno strato in memory; la modularità comprende anche la chaise longue, per la massima libertà di configurazione.

èS. is a sofa that defines being. This contemporary, comfortable and eye-catching modular range has carefully studied proportions and details, the result of research designed to combine style and substance. The deep, wide seat is even more comfortable thanks to a layer of memory foam; the range also includes a chaise longue for total composition freedom.



0109

0110
G2E

*Chiunque vive con i propri mezzi
soffre di mancanza di immaginazione.*

*Anyone who lives within their means
suffers from a lack of imagination.*

Oscar Wilde

**Siamo per lo stile, i tessuti, la materia.
Siamo per la contemporaneità, comprese
le sue contraddizioni. Siamo per l'espressione
delle passioni e degli istinti. Siamo ospitali,
disponibili, siamo nostalgici e innovativi.
Siamo per tutto ciò che rappresenta l'Essere.**

We love style, fabrics, textures.

**We love contemporaneity, with all
its contradictions. We love expressing
our passions and instincts. We are
hospitable, willing, nostalgic and innovative.
We are everything that represents Being.**



0111

Cat. K Art. D61/001



0112

ESSE

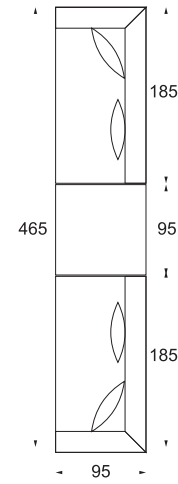
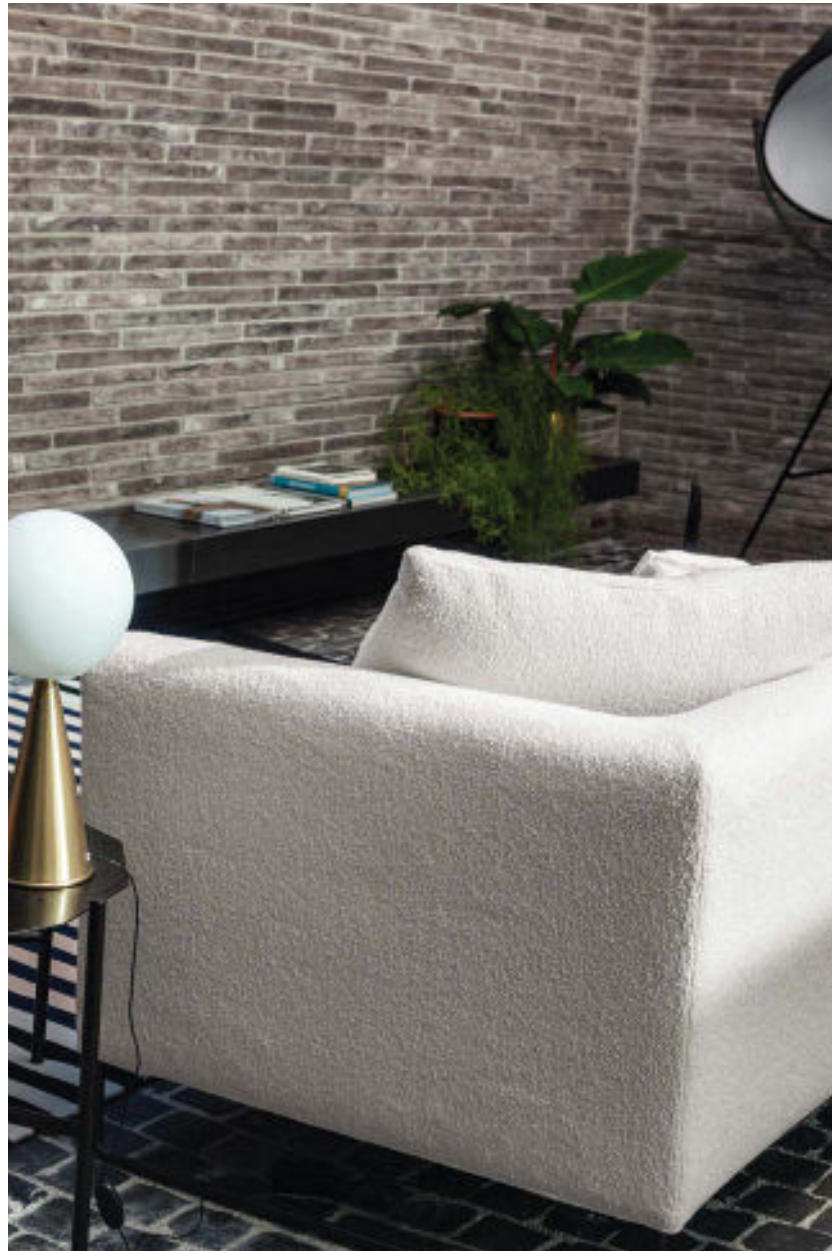

La gamma Twils Lounge è ricca di personalità, carattere e concretezza. Ma anche di morbidezza, classe e charme. Con èS. abbiamo dato forma compiuta a questi valori, rendendo visibile l'essenziale. Per Essere, con la E maiuscola.

The Twils Lounge range is packed with personality, character and reality. Softness, class and charm. èS. is the realisation of these values, the essential becomes visible. Being, with a capital E.

0113

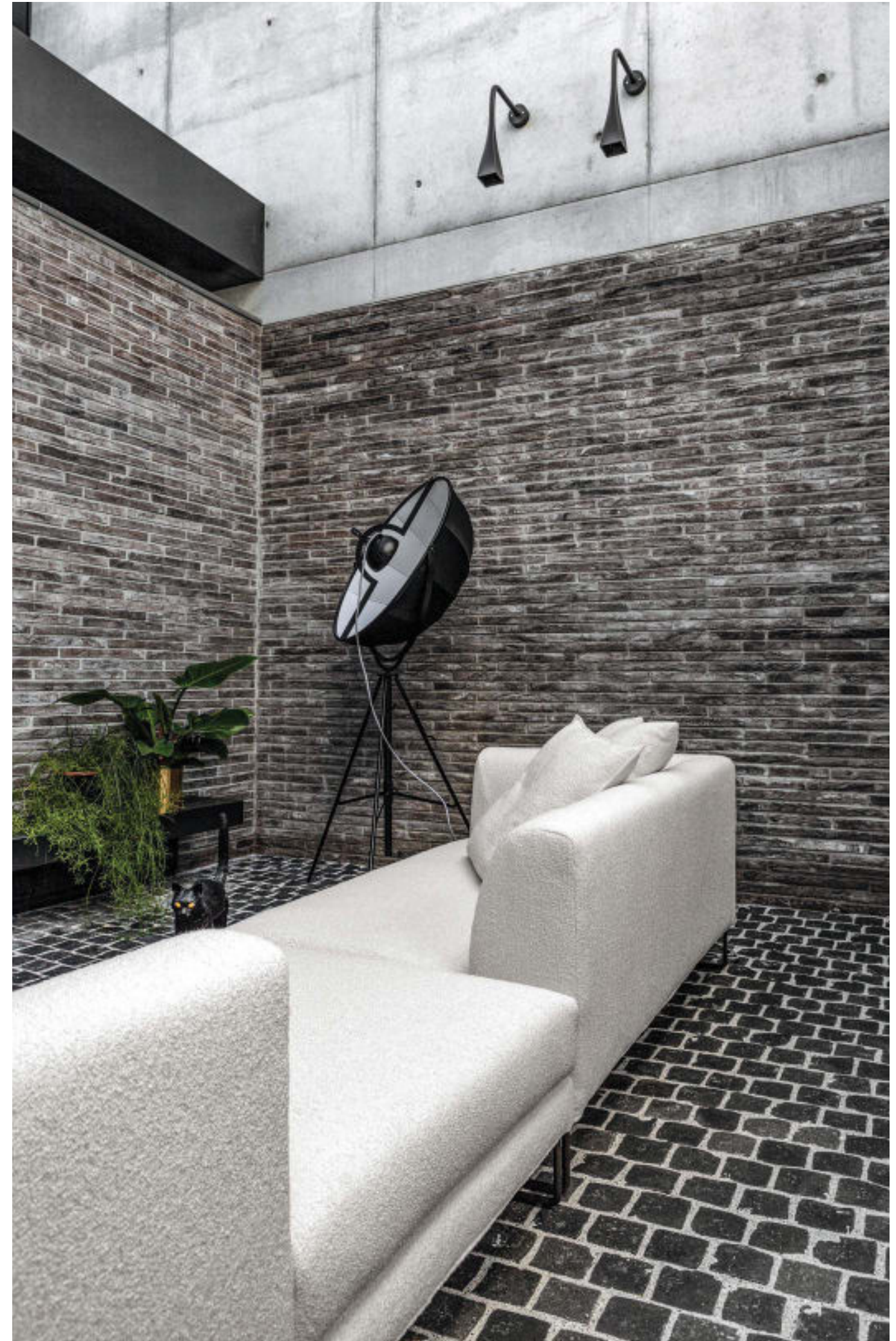



0114

LS
GE

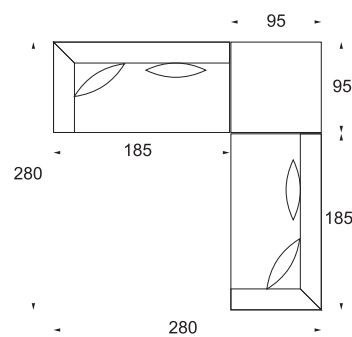

LOVE THE EXPERIENCE

L'ampia e profonda seduta di ogni singolo elemento divano è un esplicito invito al relax, amplificato dallo strato in memory presente nell'imbottitura. Lo schienale prosegue nei braccioli, offrendo la percezione di un abbraccio. Ogni dettaglio è valorizzante, da qualunque lato lo si guardi. èS. è Sorprendente.

The wide, deep seat of each element of the sofa is an open invitation to relax, reiterated by the layer of memory foam in the padding. The backrest merges into the armrests, welcoming you into its embrace. Every detail is designed to add value, whatever way you look at it. èS. is Surprising.



Name sofa:
èS.
~
Design:
R&D Twils
~
Shoot:
The importance of fades

0115

0116

GE
L5
C2



TO BE, NOT TO APPEAR

èS. è Seducente: ci attrae al primo sguardo.

È Sorridente: favorisce la convivialità.

È Sensibile: garantisce il nostro comfort.

È Straordinario: innovativo nel design, inappuntabile nello stile.

èS. is Seductive: it attracts us at a first glance.

Smiling: it suggests time spent with friends.

Sensitive: it guarantees our comfort.

Special: with its innovative design and impeccable style.



Cat. K Art. D61/001

0117



0118

GENE

SMILE MORE

LIKE

èS. non ha angoli acuti, i contorni sono morbidi e definiti. La posizione dei due grandi cuscini, posti sui braccioli o appoggiati allo schienale, determina sia lo stile che il comfort. La base è una sottile slitta metallica, contemporanea.

èS. has no acute angles, its shapes are soft but defined. The two large cushions can be placed either against the armrests or backrest, determining both the style and comfort. The metal sled base is slender and contemporary.



0119

0120

DESIGN



**IF IT'S GOOD,
IT'S WONDERFUL.**



*èS. è Seducente, Signorile e Sartoriale.
Il suo abito ideale resta l'iconico tessuto
trapuntato con cui è stato presentato
al pubblico, oggi disponibile in una gamma
di sei attraenti e attualissimi colori:
l'eleganza consiste nell'essere se stessi.*

*èS. is Seductive, Stately and Stylish.
Its ideal "suit" is the iconic quilted
fabric it was first presented to the public
with, now available in a range
of six eye-catching, ultra-modern colours:
elegance means being yourself.*

Name sofa:
èS.
~
Design:
R&D Twils
~
Shoot:
Little golden flecks

0121





0123

0124

LS
GE

EYES TALK

èS. è per chi desidera un divano composto e sempre in ordine, come detta la tradizione, però concepito secondo le tendenze contemporanee, come sa fare il buon design. La seduta è profonda e generosa, ma l'ingombro complessivo è contenuto: altro requisito moderno.

èS. is for those who want a neat and tidy sofa, as we've been taught by tradition, but one that is still on-trend, as we've been shown by good design. The seat is deep and generous but the overall space it takes up is contained: another of today's requirements.

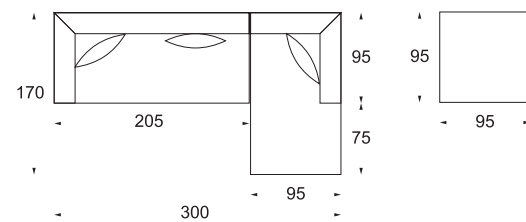

*Non sognare la tua vita,
vivi il tuo sogno.*

*Don't dream your life,
live your dream.*

Cat. K Art. D41/004



0125



0126

L
S
G
E

Name sofa:
èS.
~
Design:
R&D Twils
~
Shoot:
Living in color

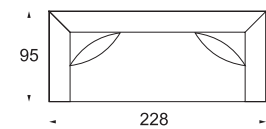

0127

THINK, BELIEVE, DREAM.

*Ho in me tutti i sogni
del mondo.*

*I have in me all the dreams
in the world.*

Fernando Pessoa

èS. mantiene intatta la sua personalità anche con tutti gli altri rivestimenti accuratamente selezionati e proposti nella gamma Twils Lounge. Anche i colori sono una parte essenziale dell'Essere.

Although the Twils Lounge range now includes an even wider range of carefully selected upholstery options, the personality of èS. is still the same. Even colours are an essential part of Being.



0128

GEZE

Una delle caratteristiche di èS.
è l'unico cuscino di seduta, profondo
e ininterrotto, così com'è ininterrotta
la base da cui si elevano i braccioli
e lo schienale. Un unico tratto continuo
che stabilisce i contorni del comfort,
con eleganza composta e discreta.

*One of the main features of èS.
is the single, deep and
uninterrupted seat cushion, just like the
uninterrupted base which the
armrests and backrest rise out of.
A single continuous line
which defines its comfortable lines
with composed, discreet elegance.*



0129

0130

GE
L5
GE

Name sofa: èS.
Design: R&D Twils

èS. è diventato un sistema completo e articolato, ricco di elementi che agevolano le più diverse configurazioni. La penisola è un tributo al comfort, il pratico pouf è una seduta in più o un piano d'appoggio.

èS. has become a complete and well-structured system, full of elements which allow a wide variety of configurations. The island is a tribute to comfort and the practical footstool provides alternative seating or a surface to place things on.

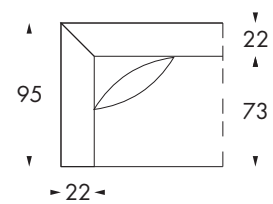
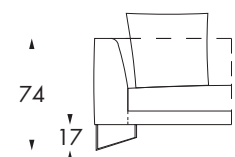
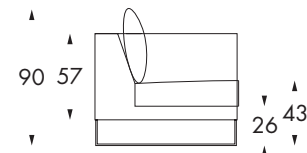

DIVANI
Sofas

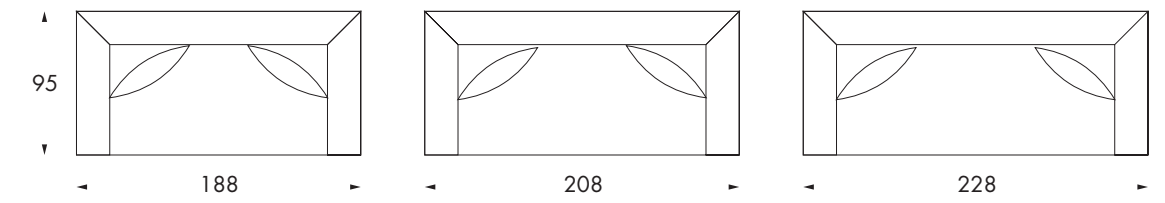

LATERALI SX
Side elements - LH

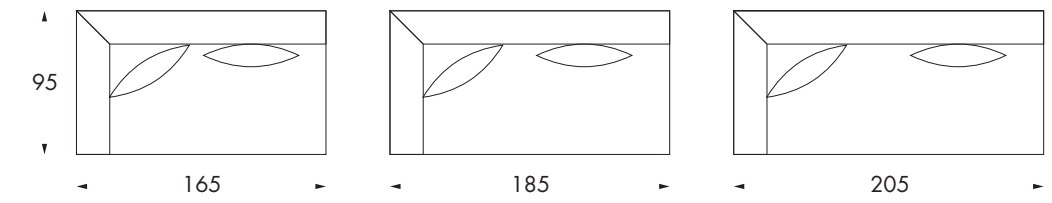

LATERALI DX
Side elements - RH

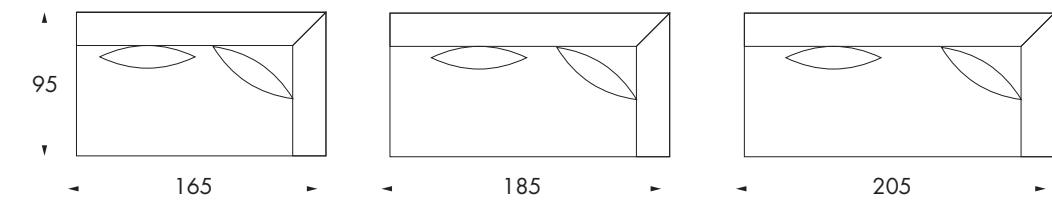

PENISOLA SX DX
Chaise Longue - LH or RH

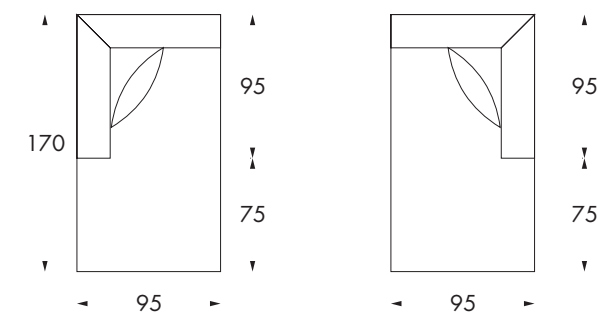

POUF
Footstool

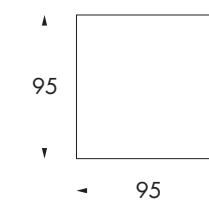

0131

0132

CS
GE

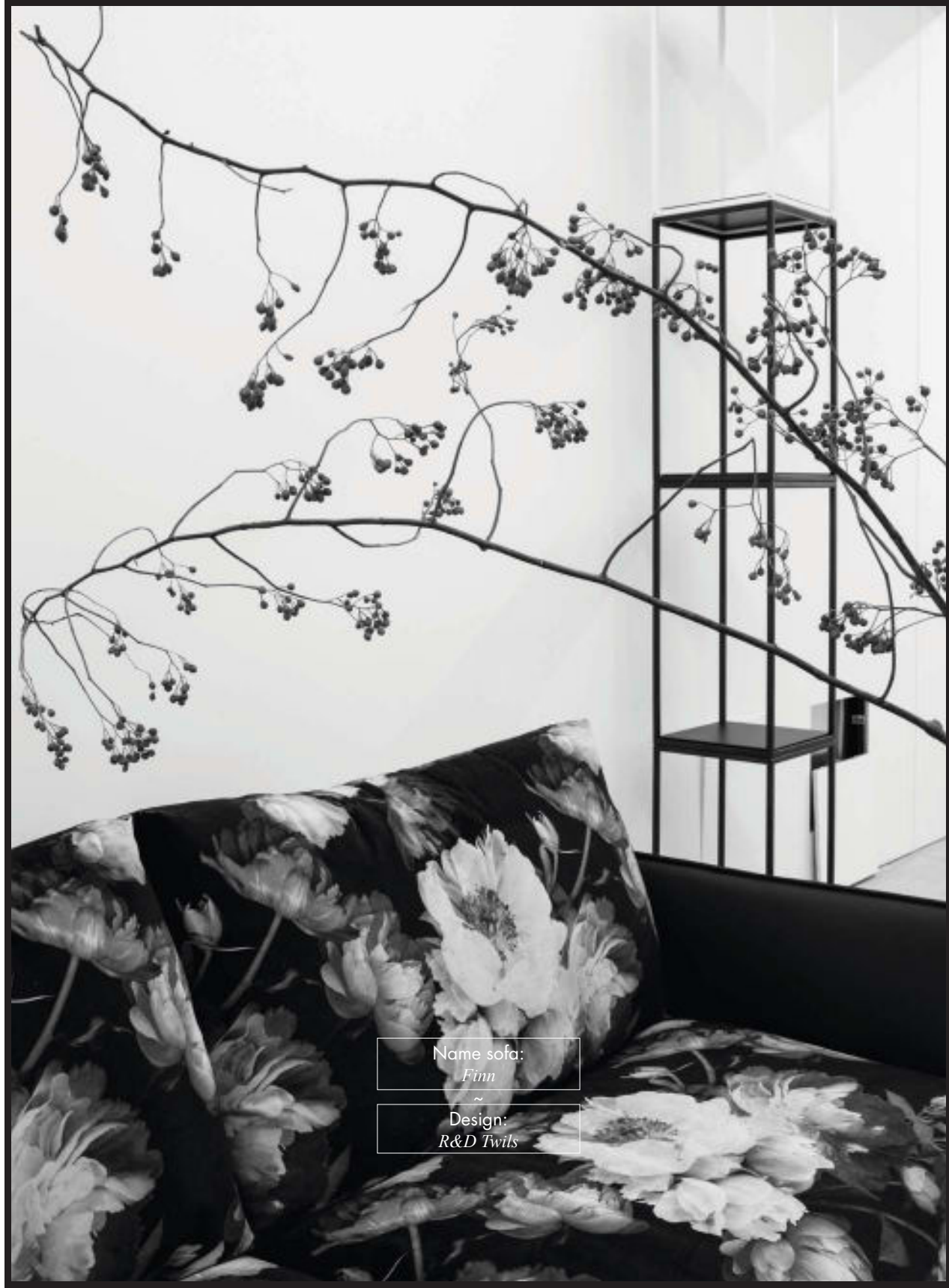

Name sofa:
Finn
~
Design:
R&D Twils

0133

Finn

Il living e la zona notte rappresentano gli ambienti della casa dove il tessile domina imprescindibile, perché sinonimo di stile, comfort e calore. La luce e le ombre disegnano i contorni della quotidianità.

The living space and bedroom are the areas in the home where fabrics are the undisputed protagonist, because they are synonymous with style, comfort and warmth. The light and shadows create the outline of everyday life.

BE HAPPY. BE BRIGHT. BE YOU.

*Nel carattere, nel modo, nello stile, in tutte le cose,
l'eccellenza suprema è la semplicità.*

*In character, in manner, in style, in all the things,
the supreme excellence is simplicity.*

Henry Wadsworth Longfellow

Name sofa:
Finn
~
Design:
R&D Twils
~
Shoot:
Notes of style



0135



0136

LUNGE

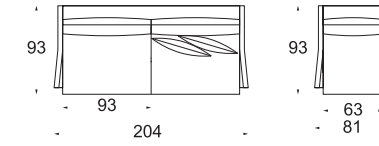

Cat. K Art. D58/053



Cat. K Art. C10/019



0137

Lo spirito contemporaneo può trovare espressione anche nella sapiente rilettura di forme e stili riconoscibili. Un esercizio che mette alla prova il design, stimolandolo a innovare rispettando i canoni formali.

The contemporary spirit can be conveyed in the intelligent reinterpretation of familiar shapes and styles. An exercise which challenges design, stimulating it to innovate while respecting formal canons.

0138

GLS
GE



*La conoscenza
è l'unica eleganza.*

*Knowledge
is the only elegance.*

Ralph Waldo Emerson

Il nome di Finn rivela l'origine dello spunto progettuale, liberamente ispirato al design scandinavo, a quella razionalità sempre misurata e armoniosa che abbiamo imparato a conoscere e la cui moda non è mai tramontata.

The name Finn reveals the inspiration for this range - Scandinavian design - that unfailingly restrained and harmonious rationality which we have learned to love and which never goes out of fashion.

0139

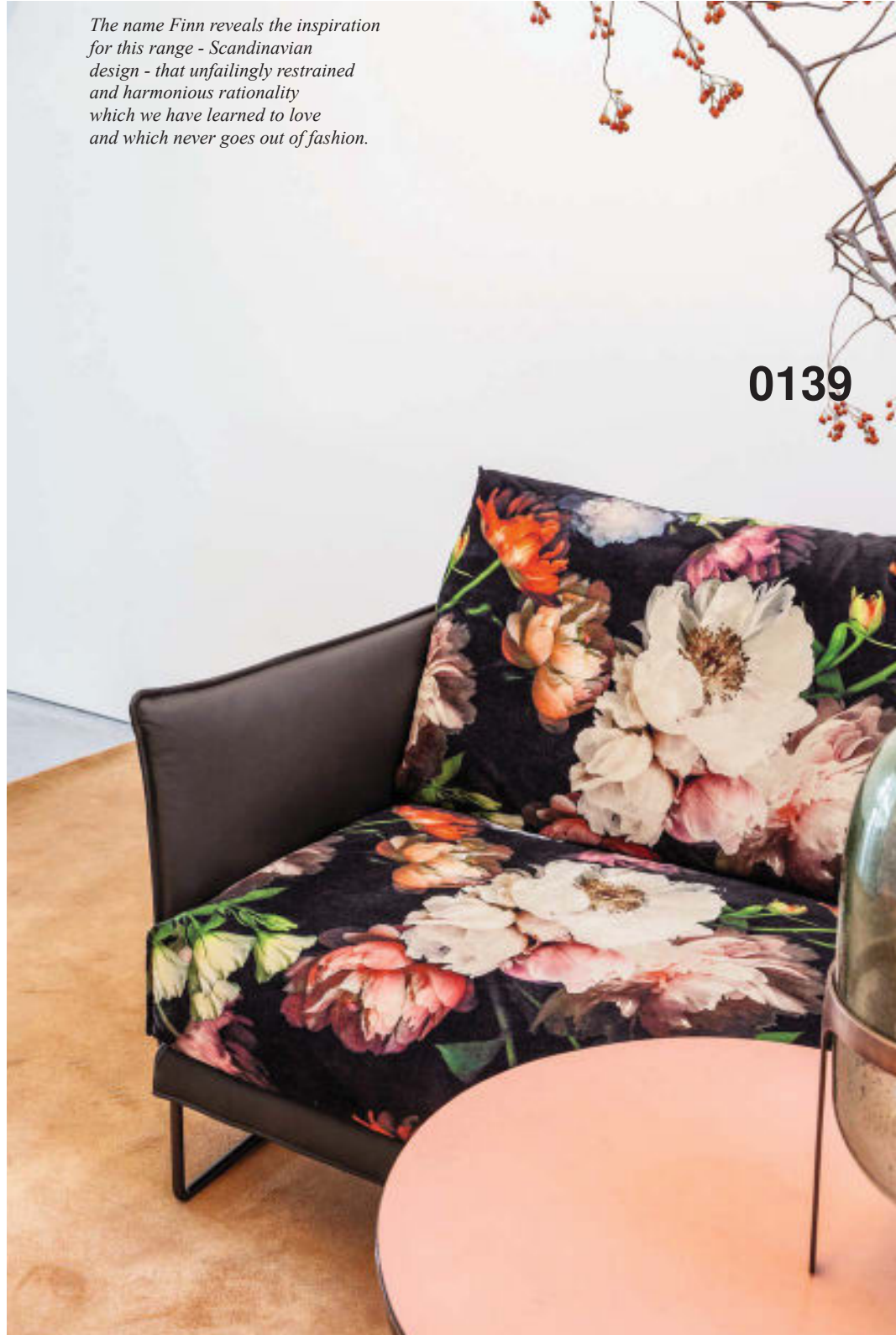

Cat. K Art. D63/001

Cat. E Art. 832/270



0140

GE
L
S

AN EXOTIC FLOWER

PICK IT UP

Il bracciolo svasato e sottile è una cifra distintiva di Finn, così come la forma dei cuscini di sapore vagamente retrò. Gli agili piedini a slitta sottolineano l'eleganza della vista d'insieme e valorizzano la leggerezza dei contorni, come lo stelo di un fiore esotico.

The flared, slender armrest is one of the defining features of Finn, together with the vaguely retro shape of the cushions. The light sled base underlines the elegance of the overall effect and enhances the light lines, like the stem of an exotic flower.

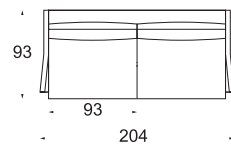

0141

0142

CS
GE

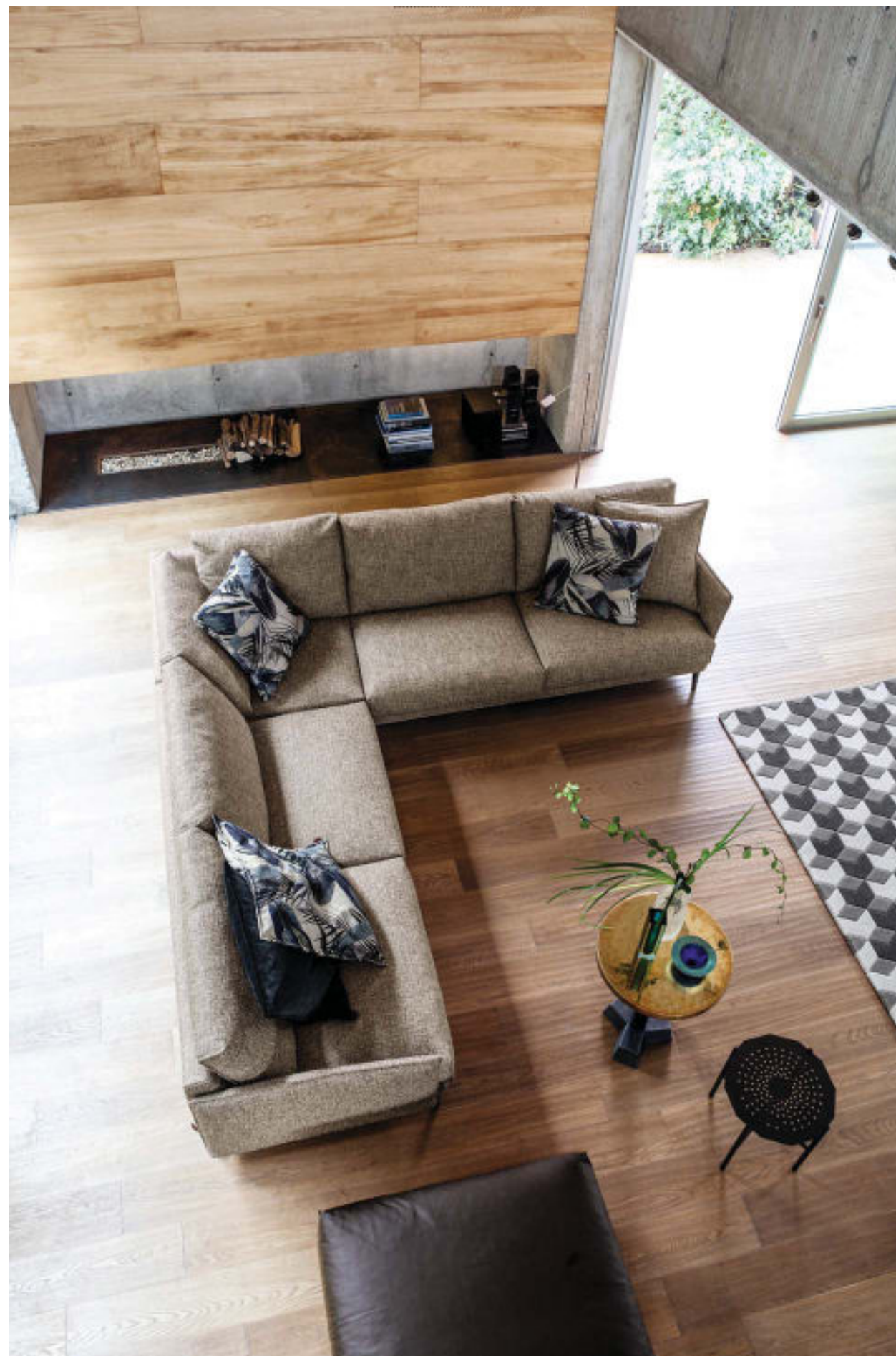

Name sofa:

Finn

~

Design:

R&D Twils

~

Shoot:

The perception of time

Finn è concepito per offrire il massimo comfort nel minimo ingombro di spazio. Per i momenti di vero relax, il sistema componibile comprende la chaise longue, la méridienne, il pouf e la poltrona singola. Le forme snelle e i volumi contenuti lo rendono adatto a creare composizioni di ampio respiro, fluttuanti e leggere.

Finn has been designed to offer maximum comfort in minimum space. For moments of pure relaxation, the modular system includes a chaise longue, dormeuse, footstool and single armchair. The slender shapes and compact volumes make it perfect for creating larger-scale, floating and light compositions.

0143

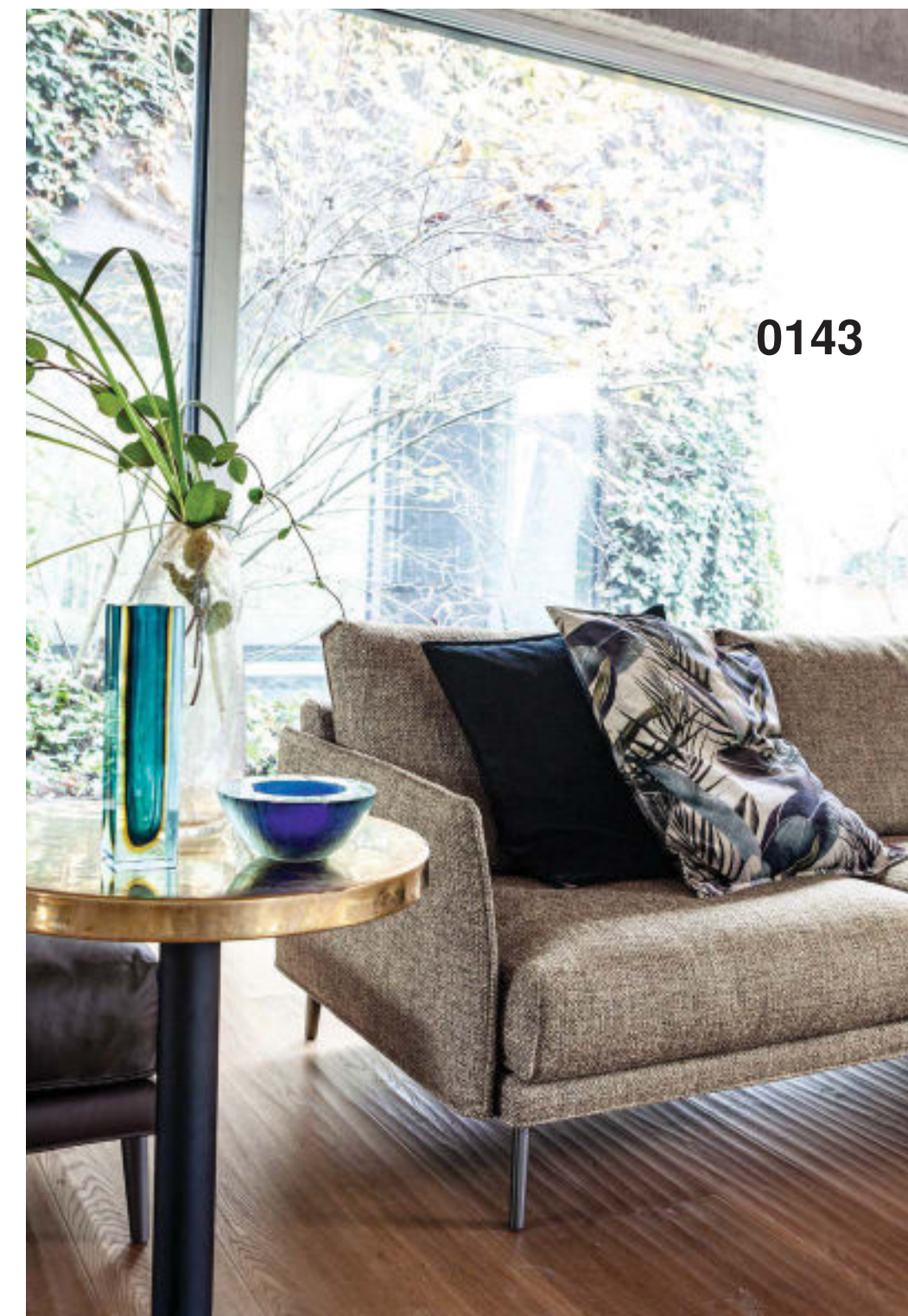

0144

LS
GE



0145

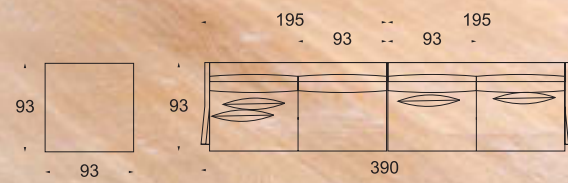



0146

ESSENCE

ELEGANCE IS AN ATTITUDE

LIKE STYLE

Il tessuto di rivestimento può essere monocromatico, per una resa formale, oppure scelto fra le tante fantasie della nostra collezione, per un risultato inatteso e creativo. Finn cambia personalità con il cambio d'abito, mantenendo sempre inalterata la sua innata attitudine all'eleganza.

The upholstery can be in one colour to create a more formal tone, or in one of the many patterns in our collection for an unexpected, creative effect. Finn changes personality as it changes its "suit", but its innate elegance remains the same.

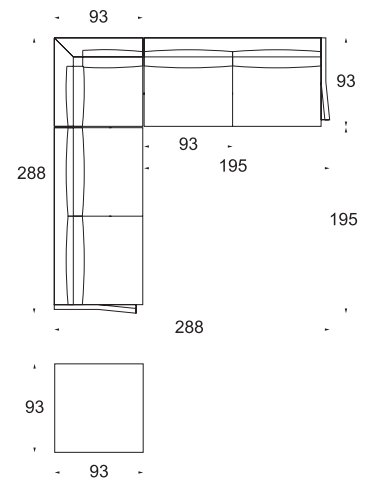

Cat. Must Art. D59/004



Cat. E Art. 832/270



0147



0148

LE
S
GE

Name sofa:
Finn
~
Design:
R&D Twils
~
Shoot:
Sequence plan



*La semplicità è la nota chiave
di ogni vera eleganza.*

*Simplicity is the keynote
of all true elegance.*

Coco Chanel

Il sistema Finn comprende anche una comoda chaise longue, elemento diventato irrinunciabile quando si parla di relax. Gli agili piedini obliqui fanno da contrappunto alla svasatura dei braccioli, sottolineando lo stile.

The Finn range also features a comfortable chaise longue, a real must-have for total relaxation. The light oblique feet are a striking contrast to the armrests, accentuating the style.



Cat. K Art. D61/006

0149

Il design nordico si è imposto nel mondo dell'arredamento per la sua sobrietà, il rigore delle linee e il décor essenziale e ricercato al contempo. È uno stile fortemente iconico, sempre funzionale, esteticamente ineccepibile. Finn rappresenta il nostro tributo a questa tendenza senza tempo.

Nordic design has become a staple in the world of furniture thanks to its simplicity, clean lines and essential yet sophisticated decor. Its style is highly iconic, always functional, aesthetically flawless. Finn is our tribute to this timeless trend.

0150

LS
GE



0151

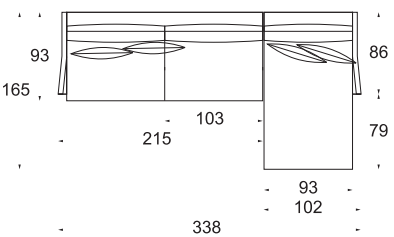

Name sofa:
Finn
~
Design:
R&D Twils
~
Shoot:
Close-up on the armchair

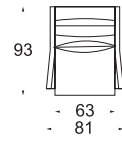

Il buon design deve tenere conto dell'estetica e della funzionalità, senza dimenticare che gli oggetti saranno immersi nella luce e nell'ambiente. Come la poltrona Finn, che ci attende silenziosa.

Two essential criteria of good design are aesthetics and functionality, without forgetting that the objects will be placed in light and a room.

Like the Finn armchair which sits there, silently waiting for us.

**L'eleganza è come le buone maniere.
Non puoi essere educato solo il mercoledì o il giovedì.
Se sei elegante, dovresti esserlo ogni giorno della settimana. Se non lo sei, allora è un'altra questione.**

Elegance is like manners.

You can't be polite only on Wednesday or Thursday.

If you are elegant, you should be every day of the week.

If you are not, then it's another matter.

0154

LUNGE

Name sofa:
Finn
~
Design:
R&D Twils
~
Shoot:
Shades of red

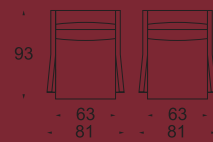

Il rivestimento di pelle e tessuto evidenzia i contorni puliti delle poltrone Finn. La superficie liscia e la superficie opaca riflettono diversamente la luce, e una semplice scelta cromatica diventa una scelta di stile.

The leather and fabric upholstery accentuates the clean lines of the Finn armchairs. The smooth and matte surfaces reflect the light differently and a simple colour choice becomes a style choice.



Cat. D Art. 679/007



Cat. E Art. 832/210



0155

0156

LINEA

Name sofa:
Finn

Design:
R&D Twils

Gli elementi che compongono il sistema Finn sono facilmente assemblabili e assicurano grande creatività modulare. A partire da un semplice divano fino alle composizioni più grandi e articolate, il living assumerà sempre un tratto di stile inconfondibile.

The elements in the Finn range are easy to assemble and guarantee great modular creativity. Whether it is a simple sofa or a large, structured composition, it will make an unmistakable style statement in the living space.

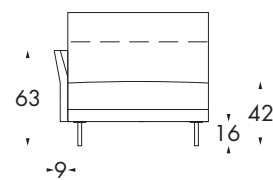
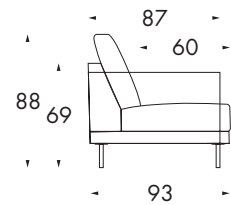

DIVANI
Sofas

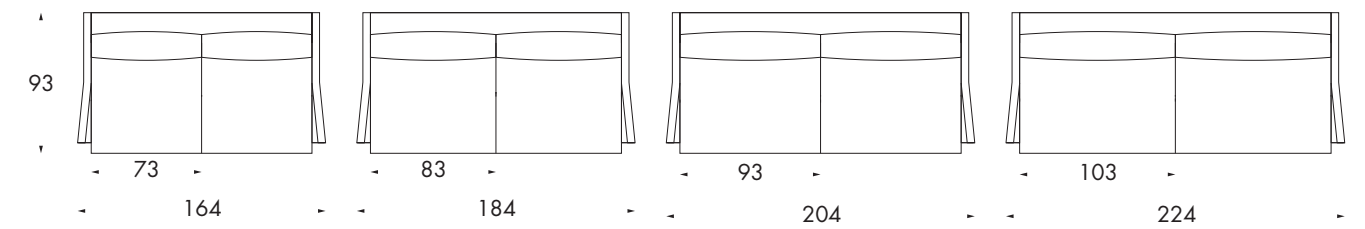

LATERALI SX
Side element - LH

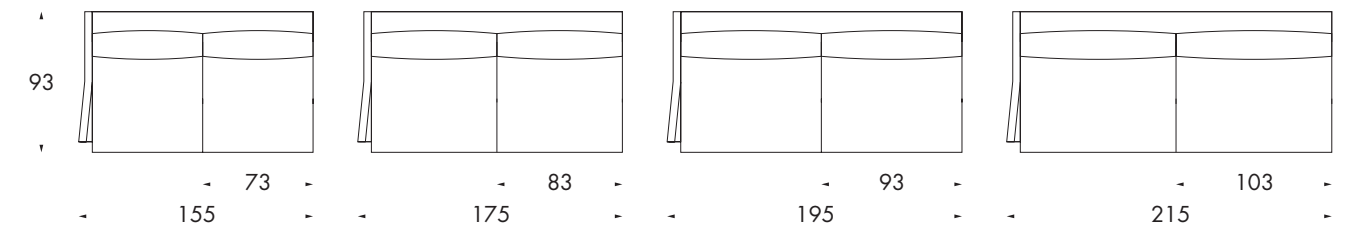

LATERALI DX
Side element - RH

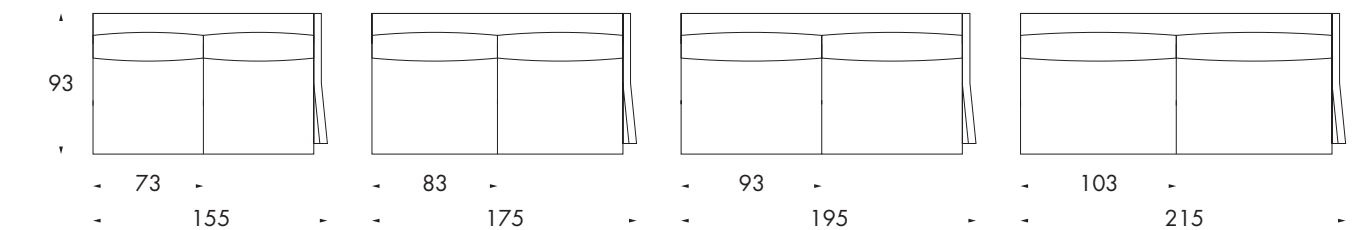

POLTRONA
Armchair

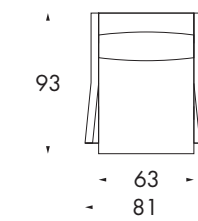

MERIDIENNE SX CON ANGOLO
Corner dormeuse - LH

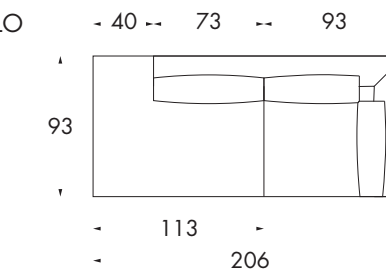

MERIDIENNE DX CON ANGOLO
Corner dormeuse - RH

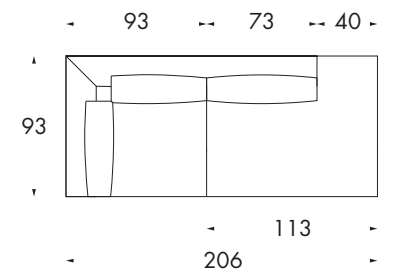

PENISOLA SX DX
chaise Longue - LH or RH

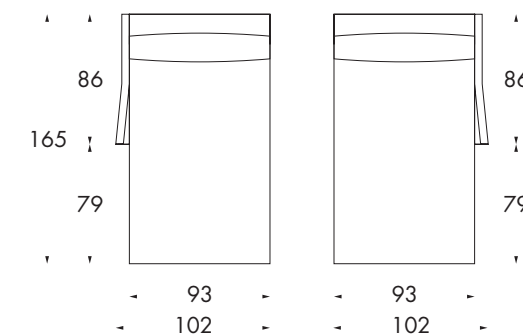

ANGOLO RETTO
Corner element

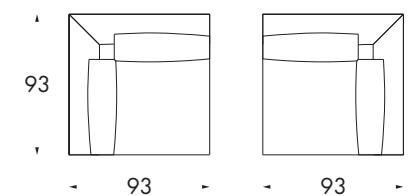

POUF
Footstool

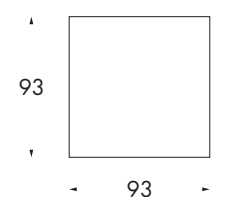

0157

Name sofa:
Revival
~
Design:
R&D Twils



REVIVAL

Ci sono forme che attraversano il tempo senza che questo sembri modificarne la percezione, tra memoria e nostalgia. Con un restyling sapiente tornano d'attualità confermandosi intramontabili.

There are shapes which appear to be unaffected by the passing years, memories and nostalgia. With intelligent restyling they are brought right up-to-date, proving they are truly timeless.

0158

LS
UN
GE

0159

Name sofa:
Revival
~
Design:
R&D Twils
~
Shoot:
Do not disturb

COLLECT MOMENTS NOT THINGS

MEMORIES

*Eleganza non significa essere notati,
ma essere ricordati.*

*Elegance is not being noticed,
it's about being remembered.*



Cat. Must Art. 969/036



0160

GENE

Lo stile di Revival è sobriamente retrò,
reinterpretato in chiave contemporanea
dall'ufficio Ricerca e Design di Twils Lounge.
Forme classiche restituite all'attualità,
per una collezione ricca di varianti dimensionali
cui vanno aggiunte le poltrone, i pratici pouf,
e adesso anche la chaise longue.

*The soberly retro style of Revival has been
given a contemporary makeover by the Twils
Lounge Research and Design department.
Classic shapes have been brought right up-to-date
to create a collection with different-sized elements,
with armchairs, practical footstools,
and now a chaise longue too.*



0161

*ELEGANCE
IS A DISCIPLINE
OF LIFE*

Con l'aggiunta del nuovo elemento chaise longue, attentamente concepito nelle proporzioni per conformarsi al canone classico di questo intramontabile divano, Revival promette un nuovo comfort. Rimane l'aspetto sobriamente formale, rimane l'armonia delle proporzioni e dei dettagli, raddoppia il relax. Con lo stile di sempre.

With the addition of the new element, the chaise longue, whose proportions have been carefully studied to satisfy the classic canon of this timeless sofa, Revival promises a new level of comfort. The soberly formal appearance is the same, the harmonious proportions and details are the same, but relaxation is doubled. And our trademark style is still the same.

0162

LS
GE



0163



I rivestimenti in tessuti materici, preziosi e ricchi di consistenza valorizzano le forme di Revival. È il ritorno dello stile formale e della convivialità composta, un modello che non è mai tramontato. Il ritorno di una foggia che ci è familiare, aggiornata e resa contemporanea da un attento restyling delle proporzioni, dei volumi e dei dettagli.

The upholstery in exquisite, textured fabrics of great substance enhances the shapes of Revival. It marks the return of formal style and composed conviviality, a model that has never gone out of fashion. The return of a familiar shape that has been brought right up-to-date by carefully restyling the proportions, volumes and details.

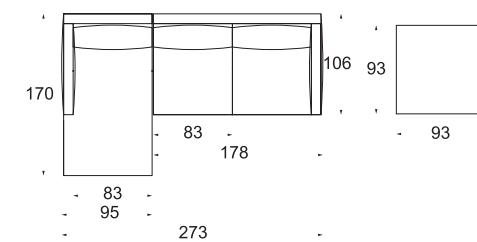

0164

LS
GE



0165



0166

CHANGE

Name sofa:
Revival

Design:
R&D Twils

Anche Revival è pensato per il comfort, garantito dallo studio delle proporzioni e dalla selezione dei materiali. Il sistema prevede tutte le configurazioni classiche e quelle più ampie e contemporanee.

Revival has been designed with comfort in mind, with carefully studied proportions and meticulously selected materials. The range offers all the classic configurations, as well as larger, more contemporary options.

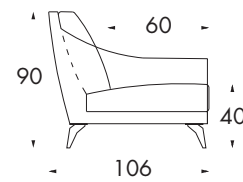
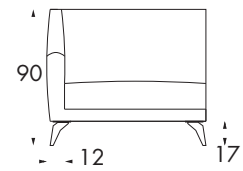

DIVANI
Sofas

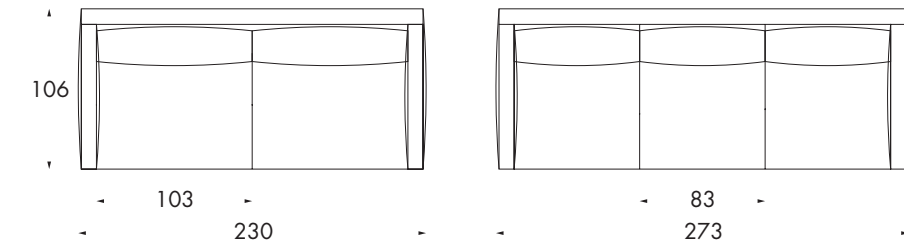
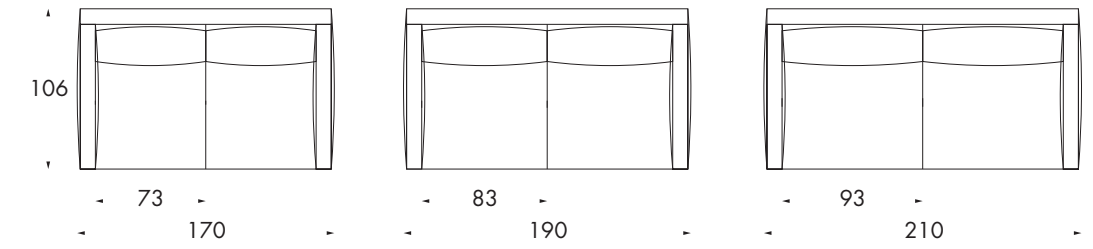

POLTRONE
Armchairs

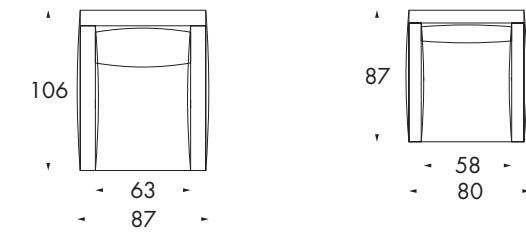

LATERALI SX
Side elements - LH

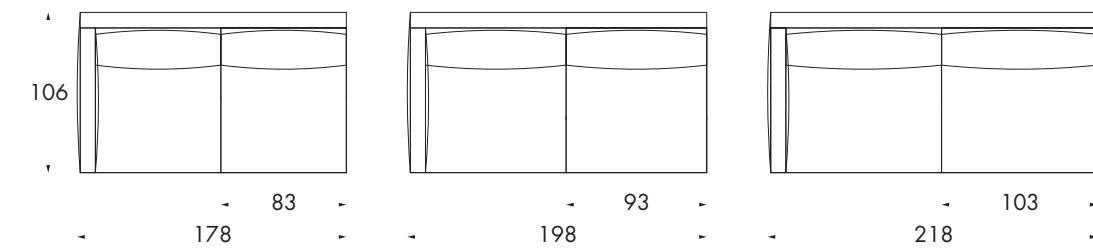

LATERALI DX
Side elements - RH

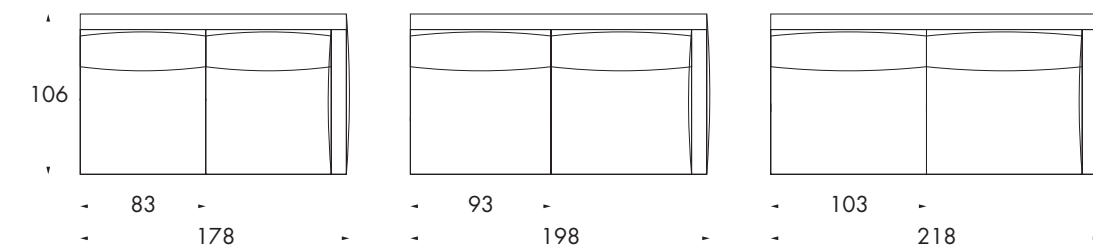

CHAISE LONGUE SX DX
Chaise Longue - LH or RH

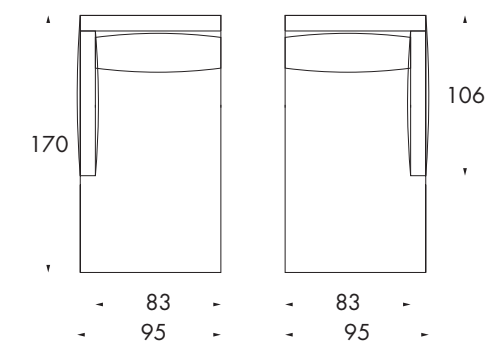

POUF
Footstool

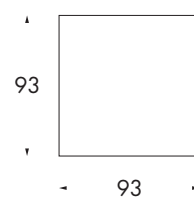

0167

Graffiti

Graffiti evoca il meritato relax, gli incontri conviviali, il piacere di stare insieme, il tempo libero e prezioso che dedichiamo a noi stessi. È un accogliente nido, soffice e spazioso, dai contorni definiti e puri.

Graffiti conjures up images of well-deserved relaxation, going out with friends, spending time together, cherished free time that we can dedicate to ourselves. It is a cosy, soft, spacious nest with defined and pure lines.

0168

Name sofa:
Graffiti
~
Design:
Studio Viganò

L
S
N
G
E

0169



Name sofa:
Graffiti
~
Design:
Studio Viganò
~
Shoot:
Look in the mirror



0170

GE
C15
C2E

Graffiti è un sistema componibile dinamico e contemporaneo, che pone sullo stesso piano privilegiato l'estetica e il comfort. Il meccanismo di alzata studiato per i cuscini dello schienale consente di regolare la posizione del corpo, per personalizzare il comfort.

*Graffiti is a dynamic, contemporary modular system which places aesthetics and comfort on the same privileged level.
The lift mechanism for the cushions on the backrest allows you to adjust your position to personalise your comfort.*

NOSTALGIA IS A SEDUCTIVE LIAR

*Il contenuto viene prima del design.
Il design, senza contenuti, non è design, è decorazione.*

*Content precedes design. Design in the absence
of content is not design, it's decoration.*

Jeffrey Zeldman



Cat. K Art. C10/010



Cat. Must Art. D46/004



Cat. K Art. D08/004

0171



0172

L
U
N
G
E

Il divano a tre posti con penisola è ormai diventato un classico del living contemporaneo, perché offre grande comfort in poco spazio. L'accogliente poltrona Graffiti è ampia e invitante, i suoi grandi braccioli sono la parentesi che accoglie il nostro relax.

The three-seater sofa with island has become a classic in modern-day living spaces because it provides maximum comfort in minimum space. The cosy Graffiti armchair is generously proportioned and inviting, its large armrests are like brackets, welcoming us into their relaxing embrace.

0173



0174

LS
GE

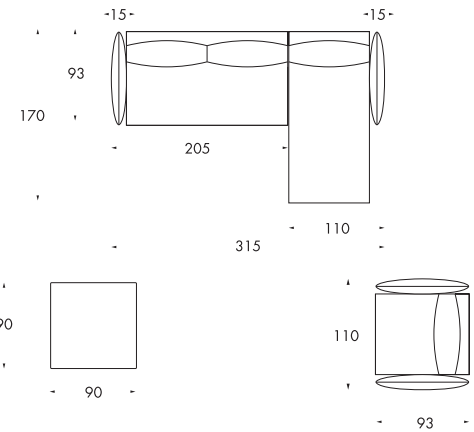

THE BEST IS YET TO COME

Nella versione con rivestimento tessile, si possono abbinare due tessuti diversi: uno per tutte le parti visibili, uno per quelle che si offrono alla vista sollevando lo schienale. Un dettaglio in linea con la cultura e il gusto sartoriale espressi da Twils Lounge.

In the fabric upholstered version, two different fabrics can be combined: one for all the visible parts and one for those which can be seen when the backrest is raised. This detail reflects the Twils Lounge philosophy and tailored style.



0175

0176

CS
GE

Name sofa: <i>Graffiti</i>
Design: <i>Studio Viganò</i>

Il design iconico, dinamico e contemporaneo di Graffiti si esprime in ogni configurazione. La poltrona singola è la sintesi dello stile che impronta tutto il sistema, i cui elementi possono essere aggregati con grande libertà compositiva, garantendo sempre un ottimo risultato estetico e funzionale.

The iconic, dynamic and contemporary design of Graffiti makes a distinctive statement in any configuration. The single armchair is the embodiment of the signature style of the system, whose elements can be combined with total freedom of expression, guaranteeing excellent aesthetic and functional results every time.

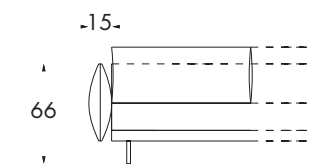
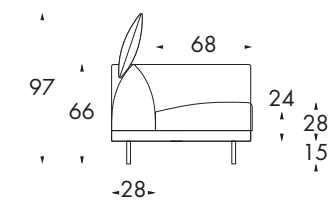
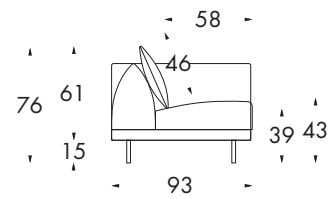

DIVANI
Sofas

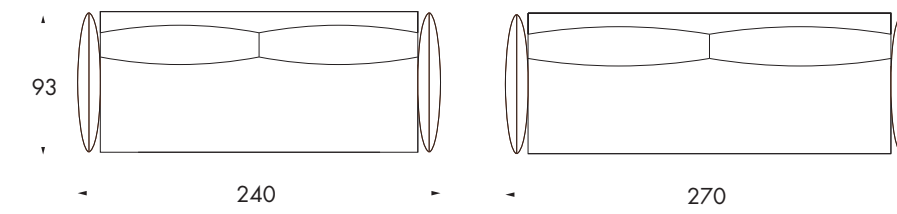
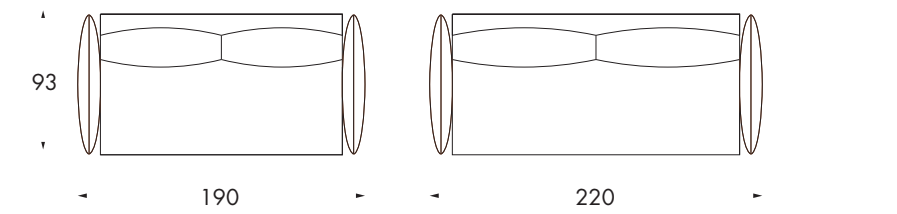

LATERALI SX
Side elements - LH

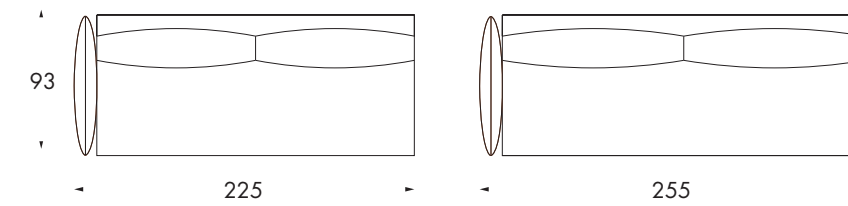
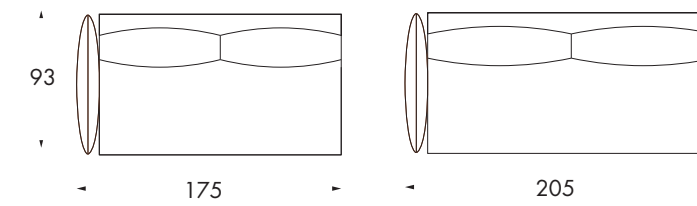

LATERALI DX
Side elements - RH

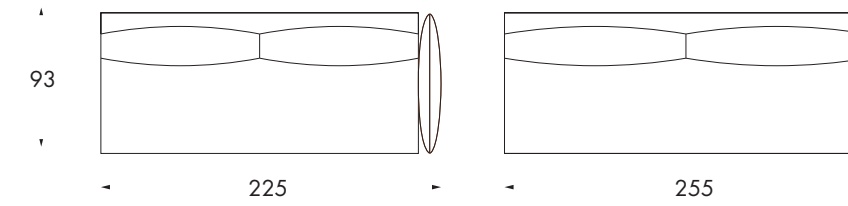
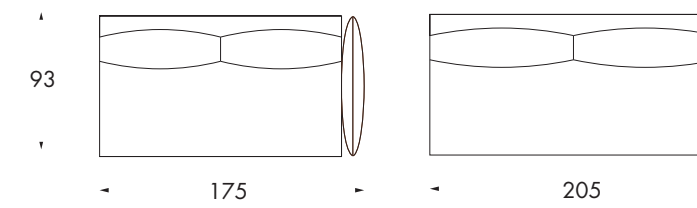

CENTRALI
Central elements

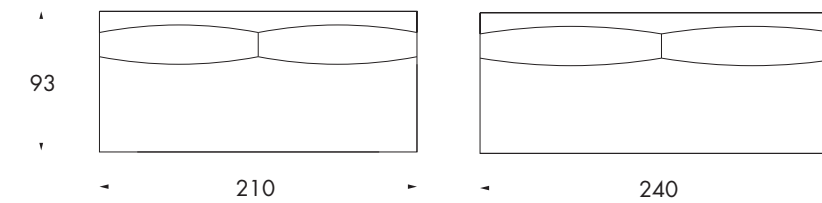
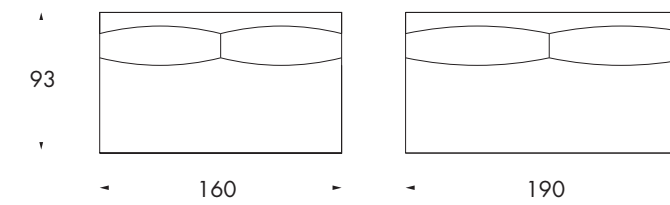

0177

0178

LONGE

Name sofa: <i>Graffiti</i>
Design: <i>Studio Viganò</i>

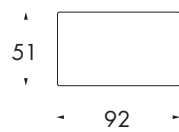
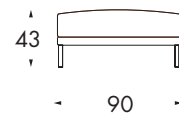
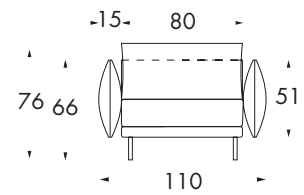
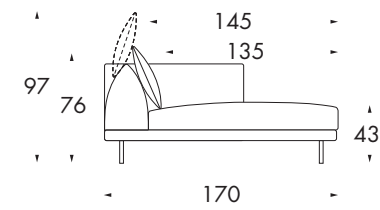

POLTRONA
Armchair

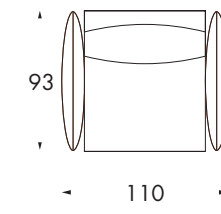

CHAISE LONGUE SX
Chaise Longue - LH

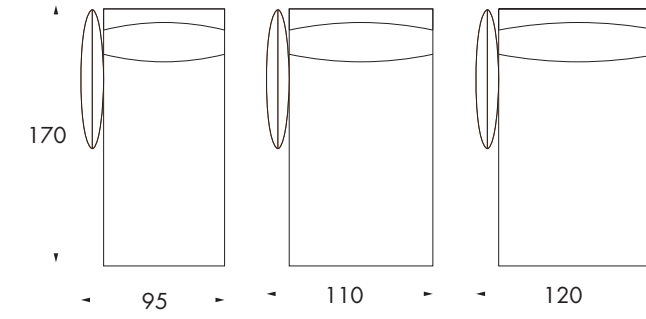

CHAISE LONGUE DX
Chaise Longue - RH

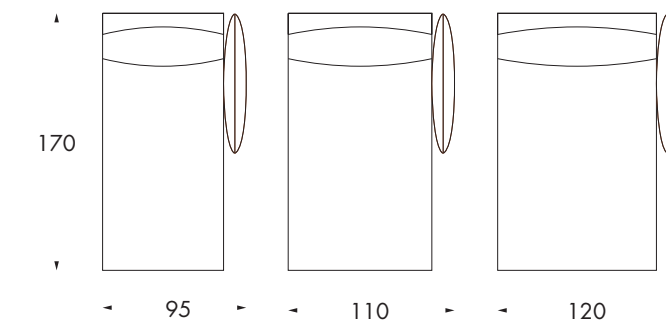

CHAISE LONGUE
Chaise longue

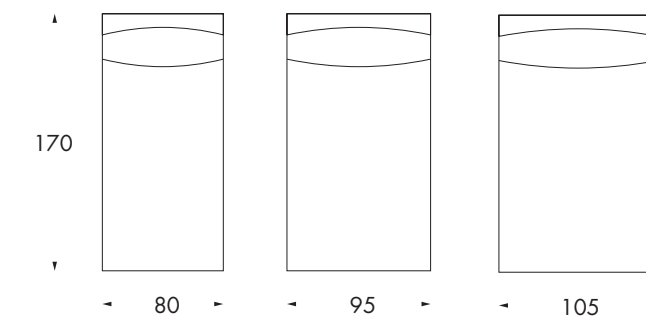

POUF
Footstool

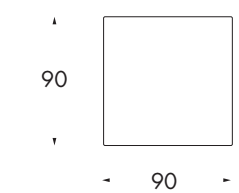

BRACCIOLO
Armrest

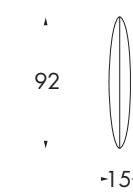

0179

Credits

Art direction & graphic:
Silvia Prevedello Studio

~

Photography:
Paolo Golumelli

~

Styling:
Anna De Cillia

~

Photolitho & Print:
Grafiche Antiga

~

Thanks to:
Gervasoni
Paola Paronetto
Carpet Edition

Twils LOUNGE
Gruppo Twils®

Via degli Olmi, 5
31040 Cessalto (TV)
Italy

T. +39 0421 469011 R.A.
T. +39 0421 469090 uff. comm.
T. +39 0421 469050 uff. sped.
F. +39 0421 327916

www.twislounge.it
info@twislounge.it