

FORMA MINIMA

-
LAMP/S & DÉCOR/S

**COLLECTION
CATALOGUE**

High-end Lightings and Décors
finely handcrafted in Italy

WWW.FORMAMINIMA.COM

/INDEX

Company Profile	1
Mission	4
Artisanal know-how	5-6
Lamp/s Collection	
Lamp/One Limited Editions:	7-18
Colour, Revamp, Black Ed.	
Limited Editions - Technical Spec.	19-32
Lamp/One Collection Suspension lights	34
The Single Suspensions Serie - Technical Spec.	35-36
The Chandeliers Serie - Technical Spec.	37-46
Lamp/Two Collection Table lights	47-50
Lamp/Two Collection - Technical Spec.	51-52
Lamp/Two Limited Editions:	
Colour, Revamp, Black Ed.	53-62
Limited Editions - Technical Spec.	63-68
Décor/s Collection	
Mirror/Zero Collection	69-74
Technical Spec.	75-80
Curiosité Collection - Décor Boxes	81-90
Technical Spec.	91-94
Contacts	96

/COMPANY PROFILE

Boldly making our mark on the Italian design scene, our emerging lighting and décors Brand strives to push the boundaries of excellence and precision in traditional craftsmanship through rigorous research and the synergy of carefully selected local artisans.

Our journey starts from a compelling exploration of tradition, the artisan mastery, and that making full of charm, care, and perseverance that characterizes the finest Italian craftsmanship.

Therefore each Formaminima creation is crafted in those same places where the know-how is handed down and thoroughly kept for generations, exclusively in our territory. Carefully selected workshops, ateliers, and studios become our precious partners in the realization of every single piece, merging sought-after materials passion, re-visited production processes, and an innovative aesthetic.



LAMP
/ONE
BRASS

“Through the accurate creation of minimal objects able to inspire and intrigue, Formaminima is aimed at those admirers of an essential, sober and functional design”.



/MISSION

We create value through the masterly realization of unique pieces resulting from the direct collaboration between our designers and the excellence of Italian craftsmanship, along with its valuable know-how.

This collaboration aims at shortening and enriching each step of a local supply chain, from materials sourcing to manufacturing; in order to deliver high-quality products straight to the customer. Moreover, preserving the slow design process, as well as its fair research process and time needed to achieve the results expected, is essential to what we believe *good design* may be.

**/ARTISANAL
KNOW-HOW**

We choose the highest quality local materials, the excellence of craftsmanship informed by a contemporary design ethos.

The Master glazier ephemeral creations

The extra-clear crystal is carefully ground and finished by hand only, creating an object that, almost disappearing from view, becomes a container of light, allowing a wide and soft light diffusion in every type of environment.

The cabinetmaker secret

Expert hands, working sought-after wood surfaces tirelessly, obtaining an unparalleled quality: the result of decades of research and deep knowledge about this unique and sustainable material. Canaletto Walnut wood, Olive and walnut briarwood are the protagonists of this woodworking tradition.

The marvellous stone translucency

A cutting edge technique allows, between many others, the Calacatta, Green Alpes and Royal Pink Yellow marbles to reach such a thickness, to become permeable to light. The result is unforeseen light contrasts between veins and colour textures.

The Blacksmith precision

The satin brass, precious and durable over time, is entirely worked in our territory. The skills-full artisans of metal can exalt every detail with the utmost precision, turning solid brass surfaces joints into lightweight paper folds.

The *biscuit* thinness

The fine Porcelain from Limoges is made as thin as an eggshell, cut raw and then baked according to an innovative temperature-controlled technique, giving life to the elements that most characterize our lighting creations. Ultimately what makes our decorative objects valuable are the calibrated play of lights, softened by Porcelain warm nuances.

/LAMP
ONE
-
LIMITED
EDITIONS

LAMP
/ONE
RED

LAMP
/ONE
COLOUR EDITION

We chose to employ exclusively local materials, respecting, preserving and enhancing traditional techniques, such as marble-carving, crystal-glass grinding, Limoges porcelain mold-production. The *Colour-Edition Chandelier* shows handcrafted decorative hanging lamps realized through a selection of iconic Italian marbles, inspired by the most outstanding artistic movements of our Territory. These objects represented our tribute to *Edit Napoli 1st Edition* (June 2019).

Red Collemandina, original of Villa Collemandina, part of the “Appennino Tosco-Emiliano” National Park, is appreciated for its rich and intense chromatic tones. *Green Alpes* is extracted from the heart of Western Alps at 1.800 metres of altitude, in Val D’Aosta region. Its dramatic contrasts recall iconic architectures, thanks to its distinctive character. *Royal Pink Yellow*, belonging to the gentle landscape of Verona, is celebrated for its prestigious yet eclectic touch.



LAMP
/ONE
YELLOW



LAMP
/ONE
COLOUR EDITION
CHANDELIER



LAMP
/ONE
GREEN



/LAMP
ONE
-
LIMITED
EDITIONS

LAMP
/ONE
REVAMP EDITION

Inspired to the early '90s this outstanding eclectic Edition embraces sophisticated patterns, high-end handcrafted details and a contemporary sleek Design.

Carefully selected and locally sourced from our beautiful territory, the prized marbles: *Palissandro Blu Nuvolato* and *Arabescato Orobico* grey and orange recall forgotten atmospheres, counterbalanced by the cutting-edge industrial taste of burnished and brushed brass surfaces.

The final exquisite touch is given by the finest briarwoods of walnut and olive essences. Which represent a minimalistic reframing of the most exclusive Art Decò collections.

This Limited Edition is available in 250 pieces, numbered and signed.

LAMP
/ONE
MARBLE REVAMP_01



LAMP
/ONE

CHANDELIER REVAMP_01



LAMP
/ONE

MARBLE REVAMP_01

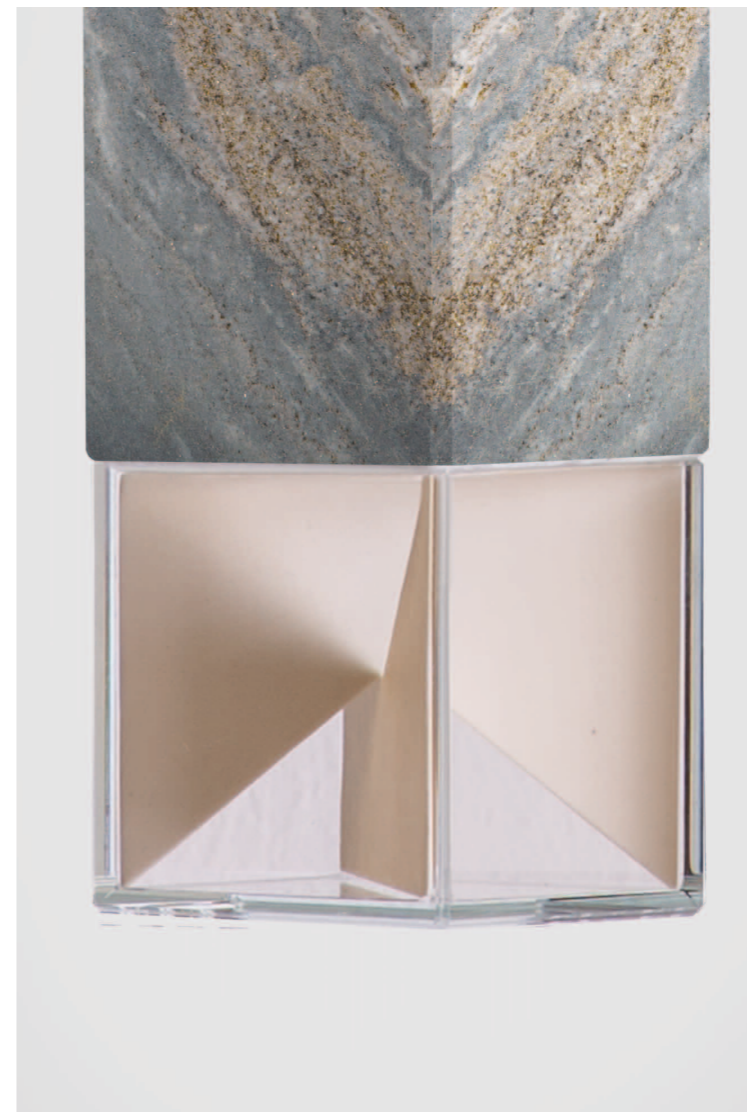

LAMP
/ONE

WOOD REVAMP_01



LAMP
/ONE

CHANDELIER REVAMP_02



LAMP
/ONE

MARBLE REVAMP_02



LAMP
/ONE

WOOD REVAMP_02

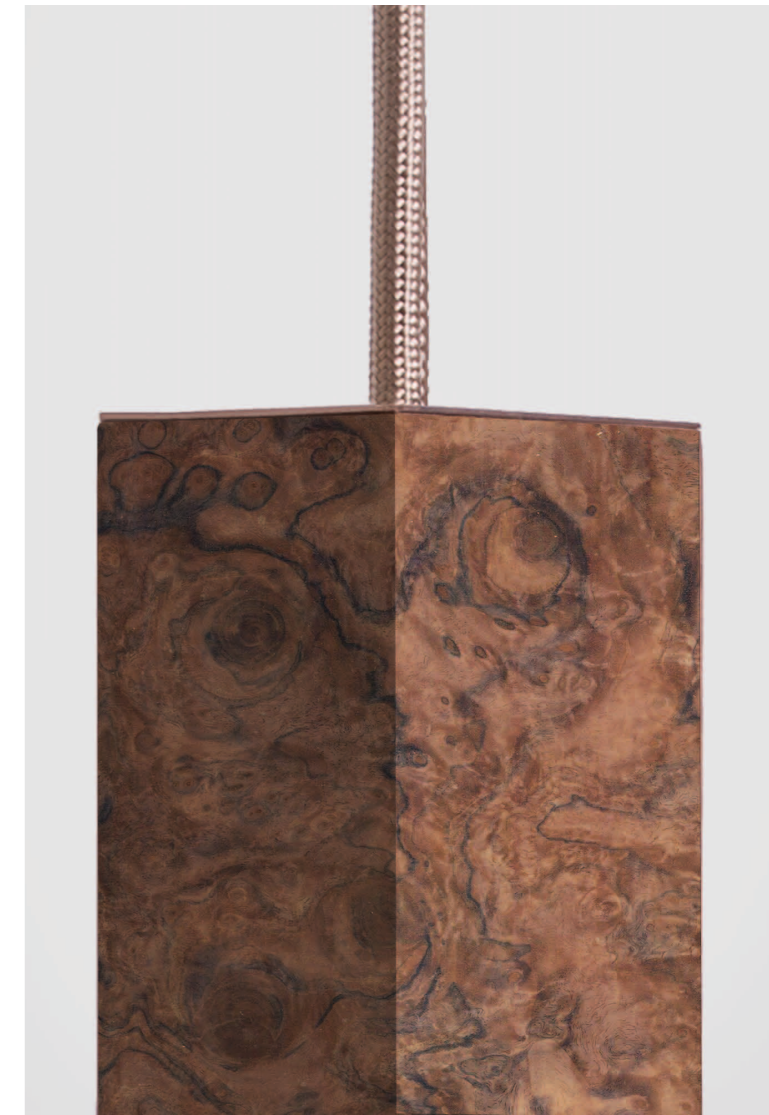

/LAMP
ONE
-
LIMITED
EDITIONS

LAMP
/ONE
BLACK EDITION

Portoro Gold marble, also known as “Black & Gold marble”, is the protagonist of this Formaminima Limited Edition, dedicated to this evergreen luxurious decorative stone. Recalling the ancient heritage of the Roman Empire, its quarries belong to the beautiful “Gulf of Poets” of Portovenere in Liguria-Italy. This prestigious polychromatic marble was employed in the decoration of Versailles castle in France, and several other remarkable historical buildings across Europe, throughout the 19th century. The velvety intense black background enriches and exalts the chromatic contrasts of large yellow-gold veins which cross the surface.



LAMP
/ONE
BLACK
6-LIGHT CHANDELIER

/TECHNICAL
SPECIFICATIONS

LAMP
/ONE
-
COLOUR EDITION
-
CHANDELIER

Lamp/One Colour Ed. Chandelier: Cod. L1-S-CE-C3

Decorative suspension lights for indoor use

Materials:

Body lamp: handcrafted solid marbles Red Collemandina, Green Alpes, Royal Pink Yellow; crystal glass diffuser, hosting Limoges biscuit-finish porcelain sheets. Ceiling rose of solid brass, satin finish

Dimensions:

h 680 (adjustable) x 300 x 300 mm
Ceiling rose: h 30 300 x 300 mm

Light source supplied per lamp:

LED 1xG9 max 2.6W, 50-60Hz G9 connection 320lm
2700K Rc 80 EU Standard compliant
Voltage: 220-240v (120v available upon request)

Supplied accessories:

Adjustable fabric cable per lamp: 2x0,75 Ø 6,2mm
minimum lenght 2m. Mounting kit: screws (4x) UX
Fischer Ø 6mm x 30mm, (1x) Anchor Fischer.



/TECHNICAL
SPECIFICATIONS

LAMP
/ONE
-
COLOUR EDITION
-
TRIO CHANDELIERS

GREEN Trio Chandelier: Cod. L1-S-GREEN-C3
RED Trio Chandelier: Cod. L1-S-RED-C3
YELLOW Trio Chandelier: Cod. L1-S-YELLOW-C3

Decorative suspension lights for indoor use

Materials:
Body lamp: handcrafted solid marbles Red
Collemandina, translucent Green Alpes, translucent Royal
Pink Yellow;
crystal glass diffuser, hosting Limoges biscuit-finish
porcelain sheets. Ceiling rose of solid brass, satin finish

Dimensions, Light source supplied per lamp,
Supplied accessories:
As featured in pages 11-12



/TECHNICAL
SPECIFICATIONS

LAMP
/ONE
REVAMP EDITION
-
CHANDELIERS

Lamp/One Revamp Ed. Chandelier _01:
Cod. L1-S-CC-RE01
Lamp/One Revamp Ed. Chandelier _02:
Cod. L1-S-CC-RE02

Decorative suspension lights for indoor use

Materials _01:
Body lamp: handcrafted solid *Palissandro Blu Nuvolato* marble, burnished satin brass, Olive briarwood, crystal glass diffuser, hosting Limoges biscuit-finish porcelain sheets. Ceiling rose of solid brass, satin finish

Materials _02:
Body lamp: handcrafted solid *Arabescato Orobico* grey and orange marble, burnished brushed brass, Walnut briarwood, crystal glass diffuser, hosting Limoges biscuit-finish porcelain sheets. Ceiling rose of solid brass, satin finish

Dimensions, Light source supplied per lamp,
Supplied accessories:
As featured in pages 11-12

LAMP
/ONE

REVAMP CHANDELIER_01



LAMP
/ONE

REVAMP CHANDELIER_02



/TECHNICAL
SPECIFICATIONS

LAMP
/ONE
BLACK EDITION
-
CHANDELIERS

BLACK Trio Chandelier: Cod. L1-S-BLACK-C3
BLACK 6-Lights Chandelier: Cod. L1-S-BLACK-C6

Decorative suspension lights for indoor use

Materials:
Black Portoro Gold vein solid marble, matt finish, crystal
glass diffuser, hosting Limoges biscuit-finish porcelain
sheets. Ceiling rose of solid brass, satin finish

Dimensions:
Trio: h 680 (adjustable) x 300 x 300 mm
6-LIGHT: h 930 (adjustable) x 300 x 300 mm
Ceiling rose: h 30 300 x 300 mm

Light source supplied per lamp:
LED 1xG9 max 2.6W, 50-60Hz G9 connection 320lm
2700K Rc 80 EU Standard compliant
Voltage: 220-240v (120v available upon request)

Supplied accessories:

Adjustable fabric cable per lamp: 2x0,75 Ø 6,2mm
minimum lenght 2m. Mounting kit: screws (4x) UX
Fischer Ø 6mm x 30mm, (1x) Anchor Fischer.

LAMP
/ONE

BLACK TRIO CHANDELIER



LAMP
/ONE

BLACK 6-LIGHTS CHANDELIER

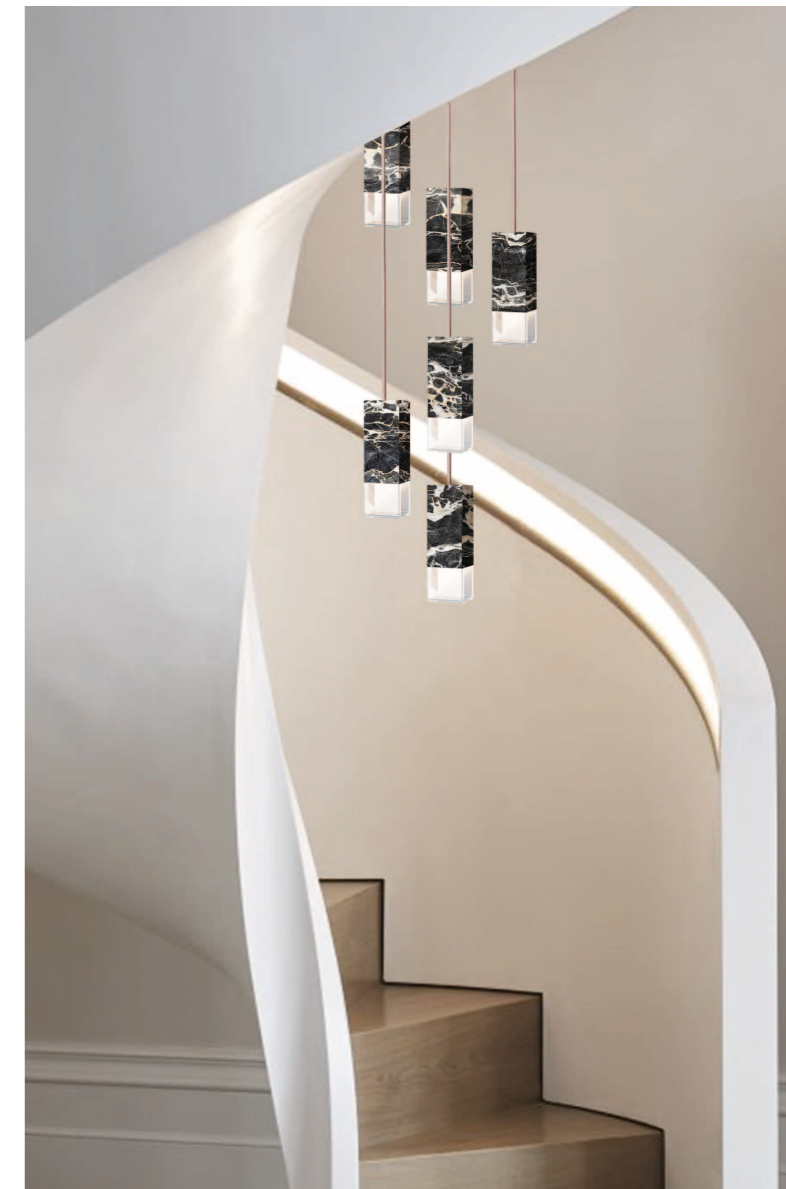

/TECHNICAL
SPECIFICATIONS

LAMP
/ONE
-
COLOUR EDITION
-
SINGLE SUSPENSIONS

Lamp/One RED: Cod. L1-S-RED
Lamp/One GREEN: Cod. L1-S-GREEN
Lamp/One YELLOW: Cod. L1-S-YELLOW

Decorative suspension light for indoor use

Materials:

Body lamp: handcrafted solid marble Red Collemantina / translucent Green Alpes / translucent Royal Pink Yellow crystal glass diffuser, hosting Limoges biscuit-finish porcelain sheets.
Ceiling rose of solid brass, satin finish

Dimensions:

Body lamp: h 170 x 50 x 50 mm
Ceiling rose: h 50 x 50 x 50 mm / ceiling rose standard
US JBOX fit: h 30 x 120 x 120 mm available upon request

Light source supplied per lamp:

LED 1xG9 max 2.6W, 50-60Hz G9 connection 320lm
2700K Rc 80 EU Standard compliant
Voltage: 220-240v (120v available upon request)

Supplied accessories:

Adjustable fabric cable per lamp: 2x0,75 Ø 6,2mm min. L 2m. Mounting kit: screws (2x) UX Fischer Ø 6mm x 30mm.

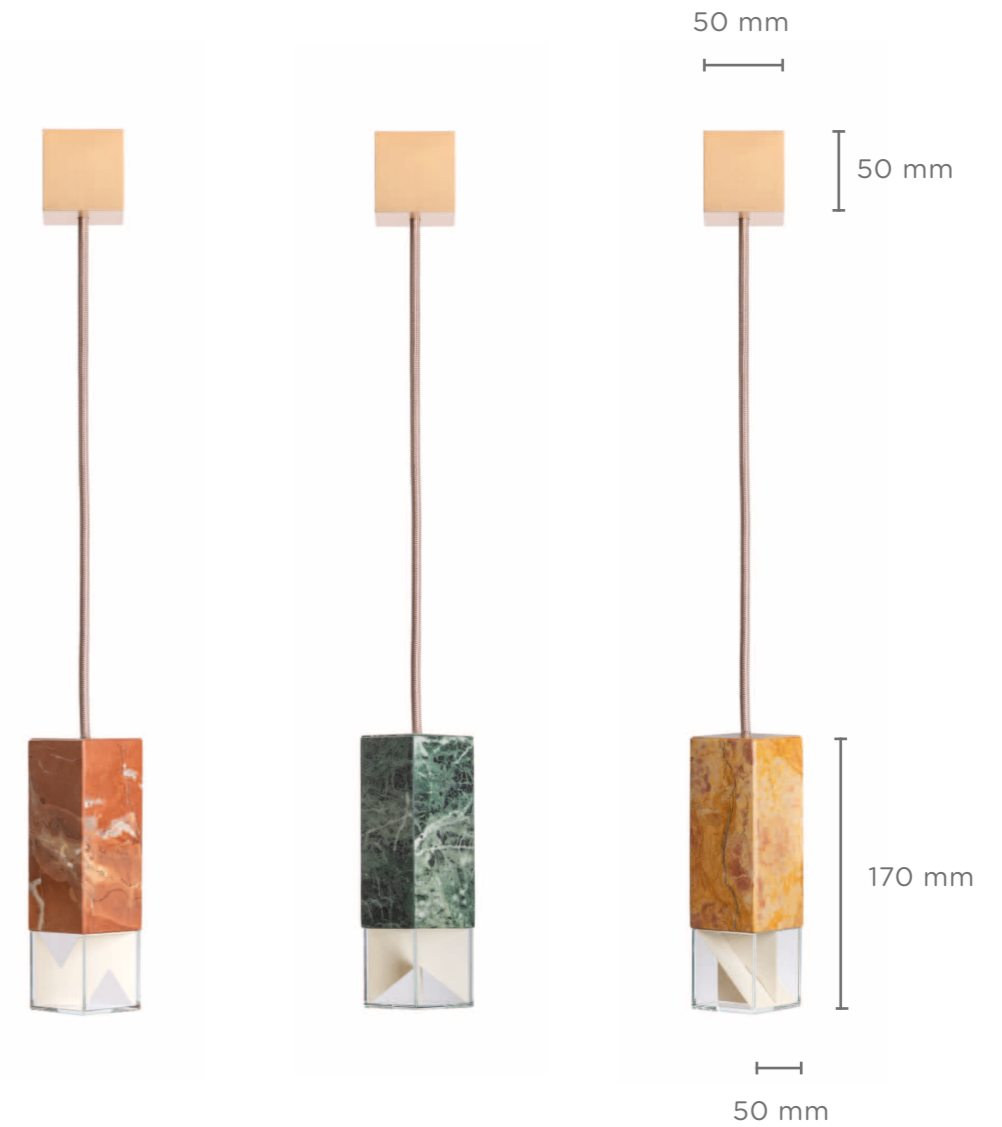

/TECHNICAL
SPECIFICATIONS

LAMP
/ONE
REVAMP EDITION 01
-
SINGLE SUSPENSIONS

Lamp/One Wood Revamp_01: L1-S-WRE01
Lamp/One Brass Revamp_01: L1-S-BRE01
Lamp/One Marble Revamp_01: L1-S-MRE01

Decorative suspension light for indoor use

Materials_01:
Body lamp: handcrafted Olive briarwood / burnished satin brass / solid *Palissandro Blu Nuvolato* marble, crystal glass diffuser, hosting Limoges biscuit-finish porcelain sheets. Ceiling rose of burnished or golden satin brass

Dimensions:
Body lamp: h 170 x 50 x 50 mm
Ceiling rose: h 50 x 50 x 50 mm / ceiling rose standard
US JBOX fit: h 30 x 120 x 120 mm available upon request

Light source supplied per lamp:
LED 1xG9 max 2.6W, 50-60Hz G9 connection 320lm
2700K Rc 80 EU Standard compliant
Voltage: 220-240v (120v available upon request)

Supplied accessories:

Adjustable fabric cable per lamp: 2x0,75 Ø 6,2mm
minimum Length: 2m. Mounting kit: screws (2x) UX
Fischer Ø 6mm x 30mm.

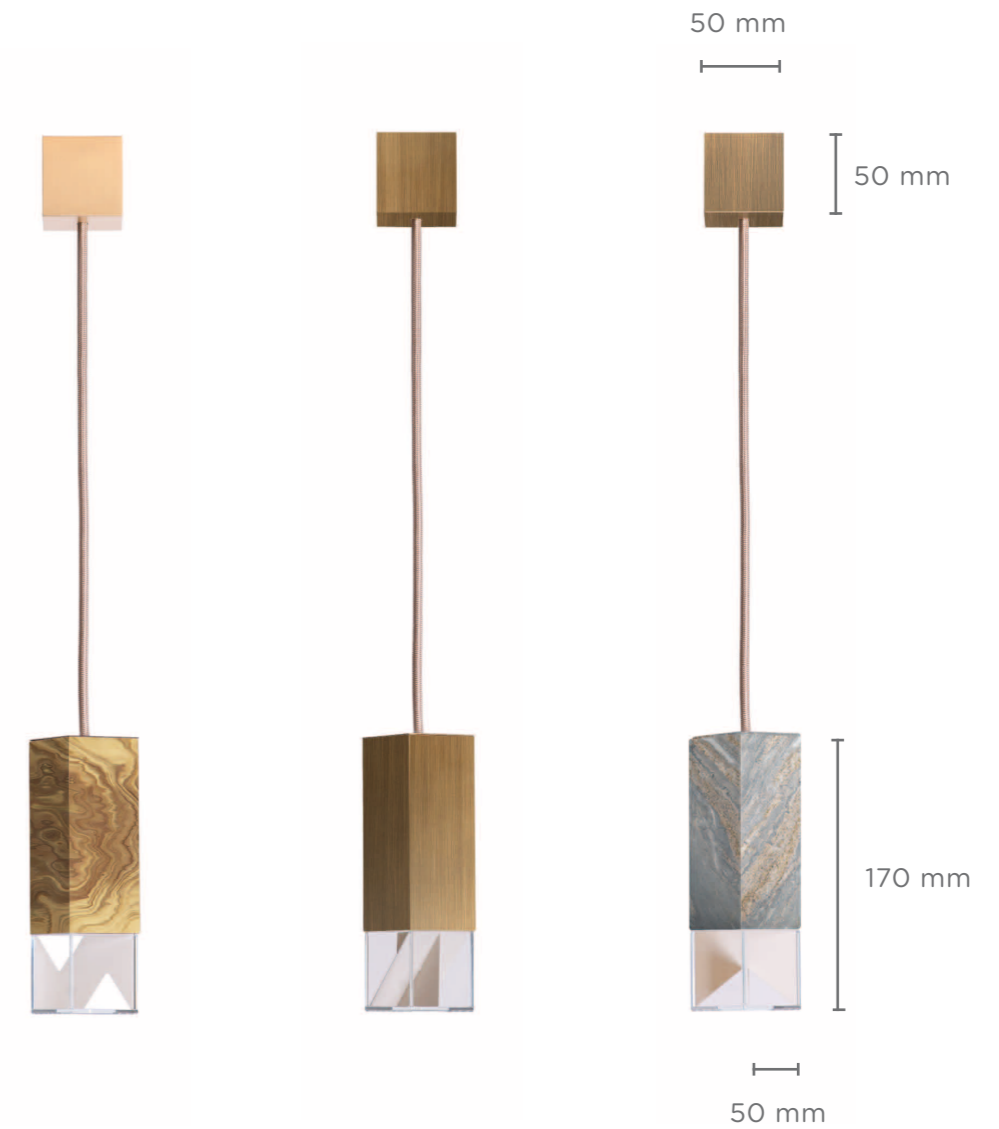

/TECHNICAL
SPECIFICATIONS

LAMP
/ONE
-
REVAMP EDITION 02
-
SINGLE SUSPENSIONS

Lamp/One Wood Revamp_02: L1-S-WRE02
Lamp/One Brass Revamp_02: L1-S-BRE02
Lamp/One Marble Revamp_02: L1-S-MRE02

Decorative suspension light for indoor use

Materials_02:
Body lamp: handcrafted Walnut briarwood / burnished brushed brass / solid *Arabescato Orobico* grey and orange marble, crystal glass diffuser, hosting Limoges biscuit-finish porcelain sheets. Ceiling rose of golden satin, brushed or burnished satin brass

Dimensions:
Body lamp: h 170 x 50 x 50 mm
Ceiling rose: h 50 x 50 x 50 mm / ceiling rose standard
US JBOX fit: h 30 x 120 x 120 mm available upon request

Light source supplied per lamp:
LED 1xG9 max 2.6W, 50-60Hz G9 connection 320lm
2700K Rc 80 EU Standard compliant
Voltage: 220-240v (120v available upon request)

Supplied accessories:

Adjustable fabric cable per lamp: 2x0,75 Ø 6,2mm min. L
2m. Mounting kit: screws (2x) UX Fischer
Ø 6mm x 30mm.

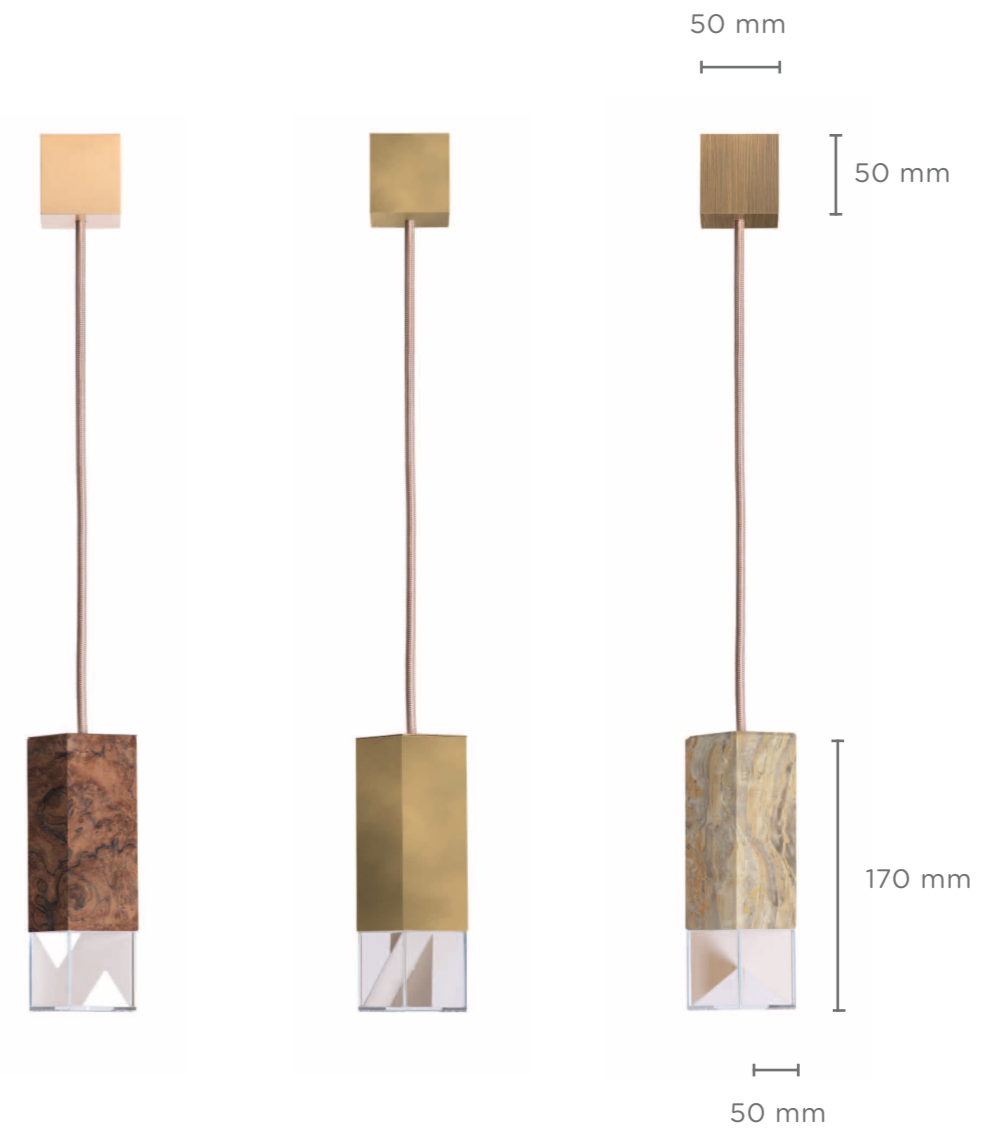



/SUSPENSION
LIGHTS

LAMP
/ONE
COLLECTION

The *Single Suspensions Serie* and *The Chandeliers Serie* are characterized by the same endless passion for fine-tuned details and statement design pieces, the genesis of the entire design process that led to the creation of the first Lamp/One Collection belongs to the world of Porcelain, to its delicate surface and structural characteristics.

Our first line of interior décor lighting was born from the exploration of two-dimensional porcelain geometries, aimed at researching the concept of lightness and thinness, bringing them to unforeseen results. Afterwards, this design journey was informed by endless curiosity, tireless research, a story about a light beam able to transform the features of a marble surface until turning it translucent, and a porcelain sheet as thin as an eggshell.

LAMP
/ONE
COLLECTION CHANDELIER

/TECHNICAL
SPECIFICATIONS
-
THE
SINGLE SUSPENSIONS
SERIE

LAMP
/ONE

WOOD
BRASS
MARBLE

Lamp/One Wood: Cod. L1-S-WW
Lamp/One Brass: Cod. L1-S-BS
Lamp/One Marble: Cod. L1-S-MCC

Decorative suspension light for indoor use

Materials:

Body lamp: handcrafted solid Canaletto Walnut wood, natural oil finish / solid brass, satin golden finish / solid Calacatta marble, translucent, matt finish; crystal glass diffuser hosting Limoges biscuit-finish porcelain sheets. Ceiling rose of solid brass, satin golden finish

Dimensions:

Body lamp: h 170 x 50 x 50 mm
Ceiling rose: h 50 x 50 x 50 mm / ceiling rose standard
US JBOX fit: h 30 x 120 x 120 mm available upon request

Light source supplied:

LED 1xG9 max 2.6W, 50-60Hz G9 connection 320lm
2700K Rc 80 EU Standard compliant

Voltage: 220-240v (120v available upon request)

Supplied accessories:

Adjustable fabric cable per lamp: 2x0,75 Ø 6,2mm
minimum lenght 2m. Mounting kit: screws (2x) UX
Fischer Ø 6mm x 30mm

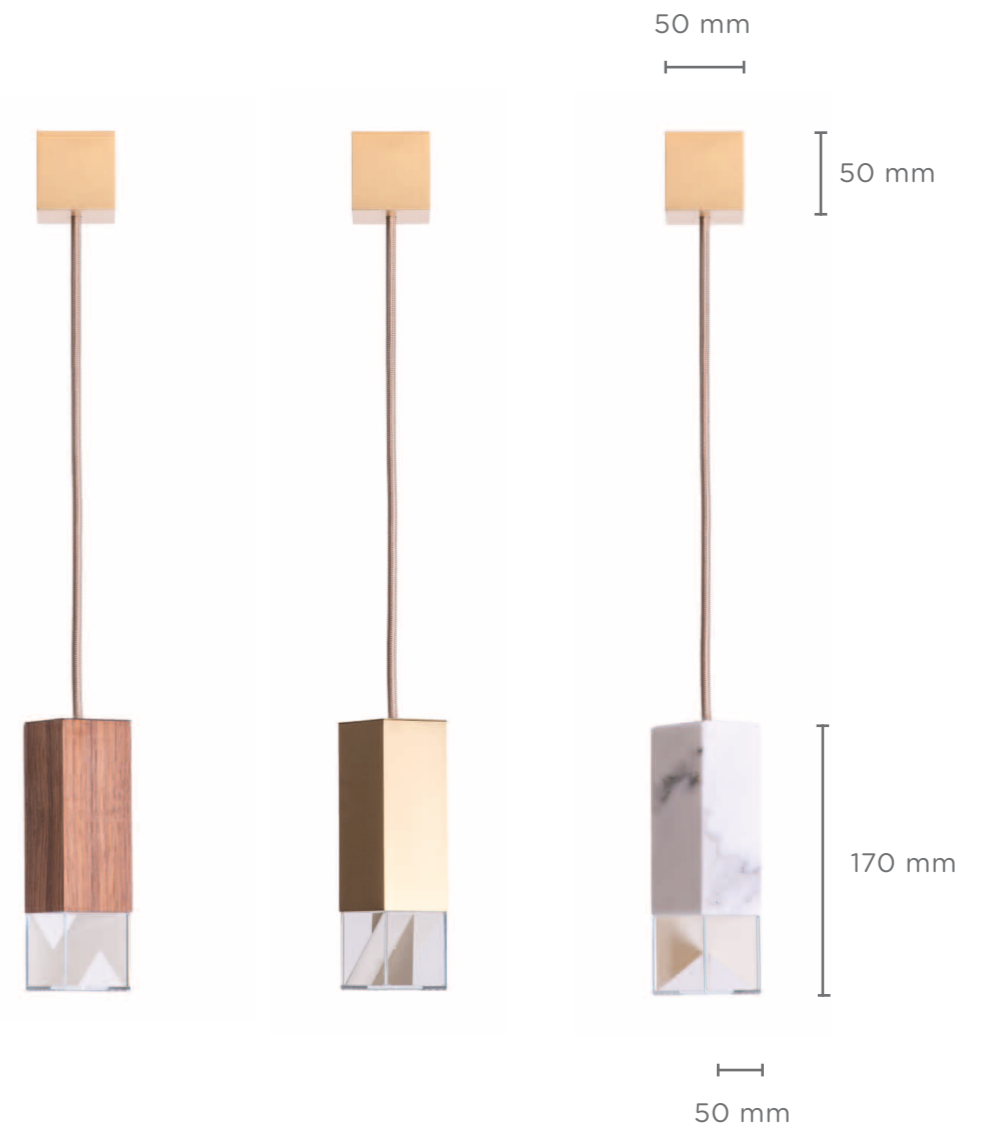

/TECHNICAL
SPECIFICATIONS
-
THE
CHANDELIERS
SERIE

LAMP
/ONE
COLLECTION
CHANDELIER

Lamp/One Collection Chandelier: Cod. L1-S-CC

Decorative suspension lights for indoor use

Materials:

Body lamps: handcrafted solid translucent
Calacatta marble, solid brass with satin finish;
solid Canaletto walnut wood, oil finish.
Crystal diffusers hosting Limoges biscuit-finish porcelain
sheets. Ceiling rose of solid brass, satin golden finish

Dimensions:

Chandelier: h 680 (adjustable) x 300 x 300 mm

Ceiling rose: h 30 x 300 x 300 mm

Body lamp: h 170 x 50 x 50 mm

Light source supplied per lamp:

LED 1xG9 max 2.6W, 50-60Hz G9 connection 320lm
2700K Rc 80 EU Standard compliant

Voltage: 220-240v (120v available upon request)

Supplied accessories:

Adjustable fabric cable per lamp: 2x0,75 Ø 6,2mm
minimum lenght 2m, Mounting kit: screws (4x) UX
Fischer Ø 6mm x 30mm, (1x) Anchor Fischer.

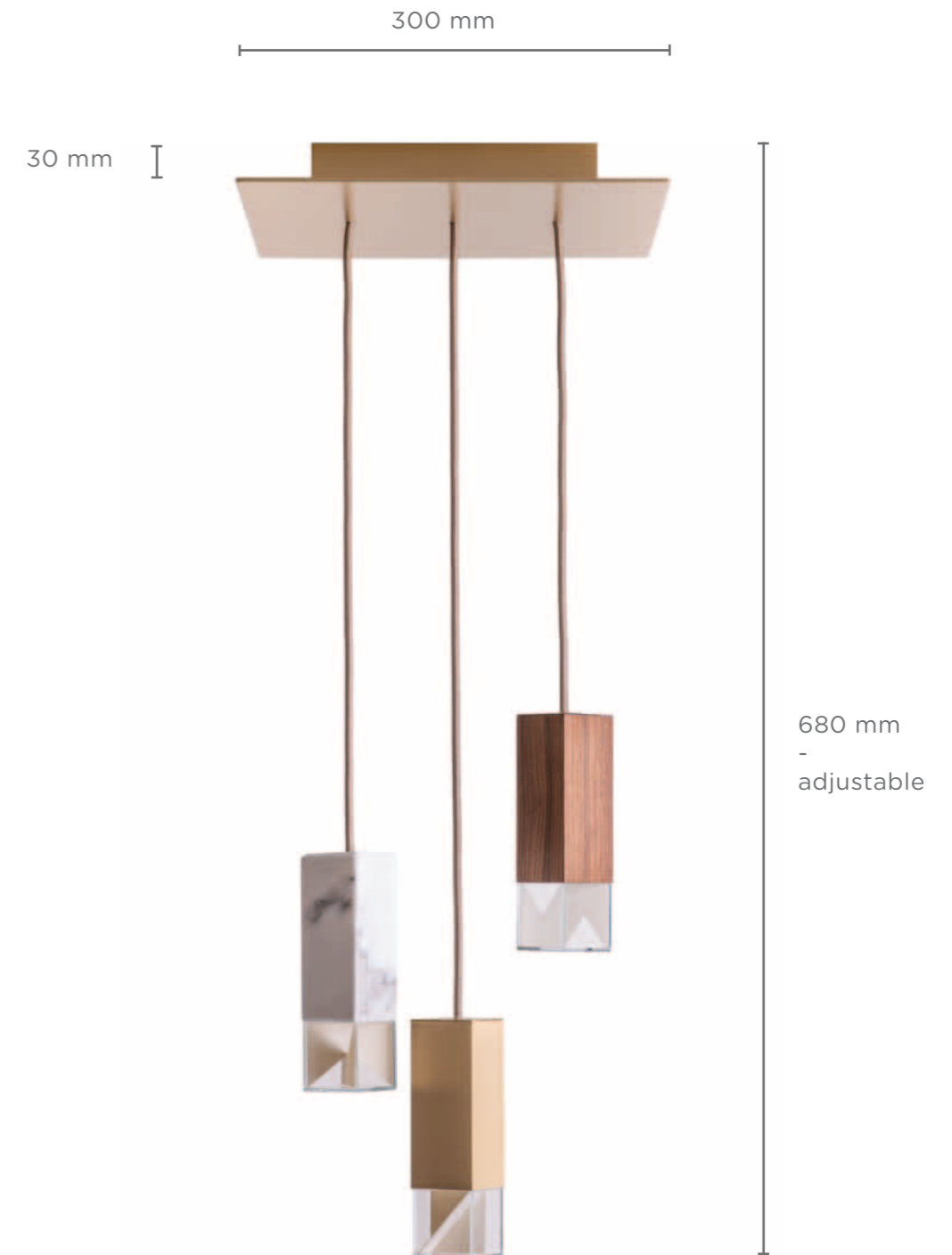

LAMP
/ONE
COLLECTION
CHANDELIER
-
DETAILS

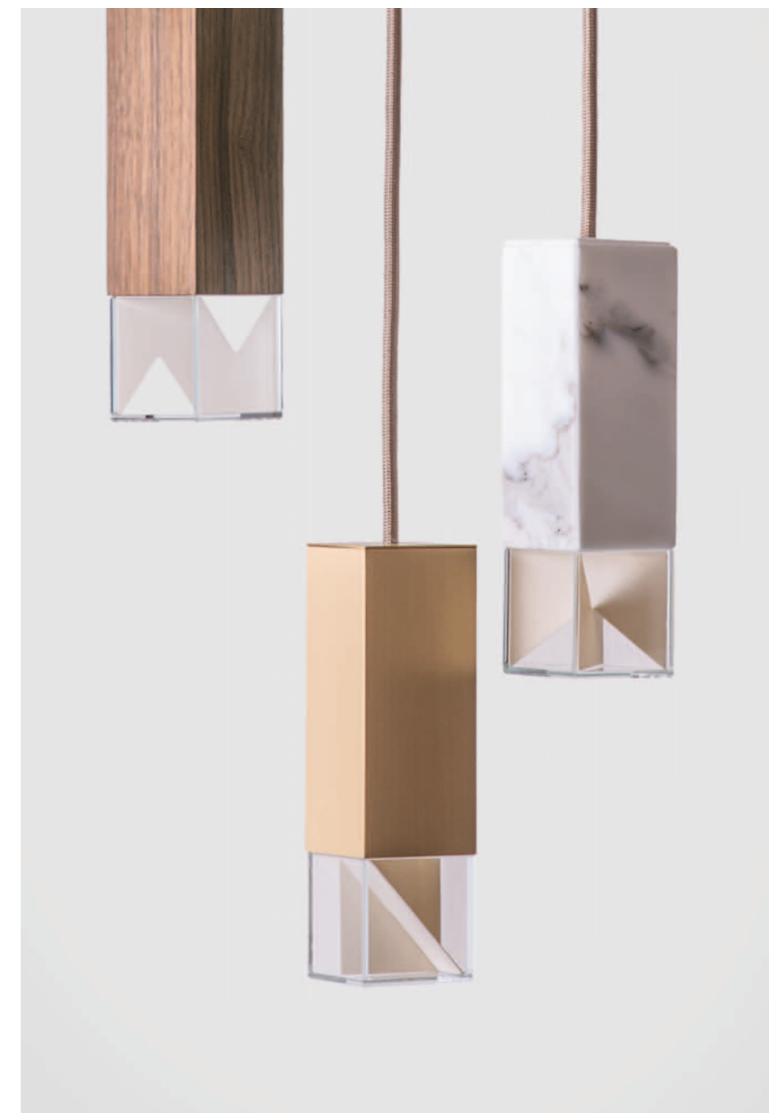



LAMP
/ONE

WOOD
-
3,6,9-LIGHT
CHANDELIERS

/TECHNICAL
SPECIFICATIONS
-
THE
CHANDELIERS
SERIE

Trio Chandelier: Cod. L1-S-WW-C3
6-LIGHT Chandelier: Cod. L1-S-WW-C6
9-LIGHT Chandelier: Cod. L1-S-WW-C9

Decorative suspension lights for indoor use

Materials:

Body lamps: handcrafted solid Canaletto walnut wood, oil finish. Ultra-thin anti-reflection crystal diffusers, hosting Limoges biscuit-finish porcelain sheets. Ceiling rose of solid brass, satin finish

Dimensions:

Trio: h 680 (adjustable) x 300 x 300 mm
6-LIGHT: h 930 (adjustable) x 300 x 300 mm
9-LIGHT: h 1.119 (adjustable) x 300 x 300mm
Ceiling rose: h 30 300 x 300 mm

Light source supplied per lamp:

LED 1xG9 max 2.6W, 50-60Hz G9 connection 320lm
2700K Rc 80 EU Standard compliant

Voltage: 220-240v (120v available upon request)

Supplied accessories:

Adjustable fabric cable per lamp: 2x0,75 Ø 6,2mm
minimum lenght 2m. Mounting kit: screws (4x) UX
Fischer Ø 6mm x 30mm, (1x) Anchor Fischer.



LAMP
/ONE

WOOD
-
9-LIGHT CHANDELIER

LAMP
/ONE

BRASS
-
6-LIGHT CHANDELIER



LAMP
/ONE

BRASS
-
3,6,9-LIGHT
CHANDELIERS



/TECHNICAL
SPECIFICATIONS
-
THE
CHANDELIERS
SERIE

Trio Chandelier: Cod. L1-S-BS-C3
6-LIGHT Chandelier: Cod. L1-S-BS-C6
9-LIGHT Chandelier: Cod. L1-S-BS-C9

Decorative suspension lights for indoor use

Materials:

Body lamps: solid brass, satin finish.
Ultra-thin anti-reflection crystal diffusers, hosting
Limoges biscuit-finish porcelain sheets.
Ceiling rose of solid brass, satin finish

Dimensions:

Trio: h 680 (adjustable) x 300 x 300 mm
6-LIGHT: h 930 (adjustable) x 300 x 300 mm
9-LIGHT: h 1.119 (adjustable) x 300 x 300mm
Ceiling rose: h 30 300 x 300 mm

Light source supplied per lamp:

LED 1xG9 max 2.6W, 50-60Hz G9 connection 320lm
2700K Rc 80 EU Standard compliant

Voltage: 220-240v (120v available upon request)

Supplied accessories:

Adjustable fabric cable per lamp: 2x0,75 Ø 6,2mm
minimum lenght 2m. Mounting kit: screws (4x) UX
Fischer Ø 6mm x 30mm, (1x) Anchor Fischer.

LAMP
/ONE
-
MARBLE
-
3,6,9-LIGHT
CHANDELIERS

/TECHNICAL
SPECIFICATIONS
-
THE
CHANDELIERS
SERIE

Trio Chandelier: Cod. L1-S-MCC-C3
6-LIGHT Chandelier: Cod. L1-S-MCC-C6
9-LIGHT Chandelier: Cod. L1-S-MCC-C9

Decorative suspension lights for indoor use

Materials:
Body lamps: handcrafted solid Calacatta marble,
translucid. Crystal diffusers, hosting Limoges biscuit-
finish porcelain sheets. Ceiling rose of solid brass, satin
finish

Dimensions:
Trio: h 680 (adjustable) x 300 x 300 mm
6-LIGHT: h 930 (adjustable) x 300 x 300 mm
9-LIGHT: h 1.119 (adjustable) x 300 x 300mm
Ceiling rose: h 30 300 x 300 mm

Light source supplied per lamp:
LED 1xG9 max 2.6W, 50-60Hz G9 connection 320lm
2700K Rc 80 EU Standard compliant

Voltage: 220-240v (120v available upon request)

Supplied accessories:

Adjustable fabric cable per lamp: 2x0,75 Ø 6,2mm
minimum lenght 2m. Mounting kit: screws (4x) UX
Fischer Ø 6mm x 30mm, (1x) Anchor Fischer



LAMP
/ONE
-
MARBLE
-
9-LIGHT CHANDELIER

/TABLE LIGHTS

LAMP
/TWO
MARBLE

LAMP
/TWO
COLLECTION

For *Lamp/Two Collection*, our mission was bringing the light a step closer, keeping the previous *Lamp/One Collection's* curated material selection and high-end crafts techniques as a leitmotiv. As a result, solid Calacatta marble, Canaletto Walnut wood and satin brass are juxtaposed to and high-lighted by a minimal structure, realized through the employment of hidden joinery, unveiling only the intersections between sober surfaces and sought-after textures.

In this Collection, the sleek brass squared tubular, enriched by the golden nuance of a satin hand-finish, designs the silhouettes of these refined table lights. These orthogonal elements gently suspend the diffuser on a brass base, softly reflecting the coming downlight into the surrounding space. The precious diffuser stands at the centre of the attention, juxtaposed to the delicacy of a crystal shade, almost invisible in the dark, unveiling extra-thin porcelain geometries from Limoges. These translucid and ephemeral biscuit layers provide sophisticated and unexpected plays of light when touched by the coming down-light.



/TABLE LIGHTS

LAMP
/TWO
DETAILS



/TECHNICAL
SPECIFICATIONS

LAMP
/TWO
WOOD
BRASS
MARBLE

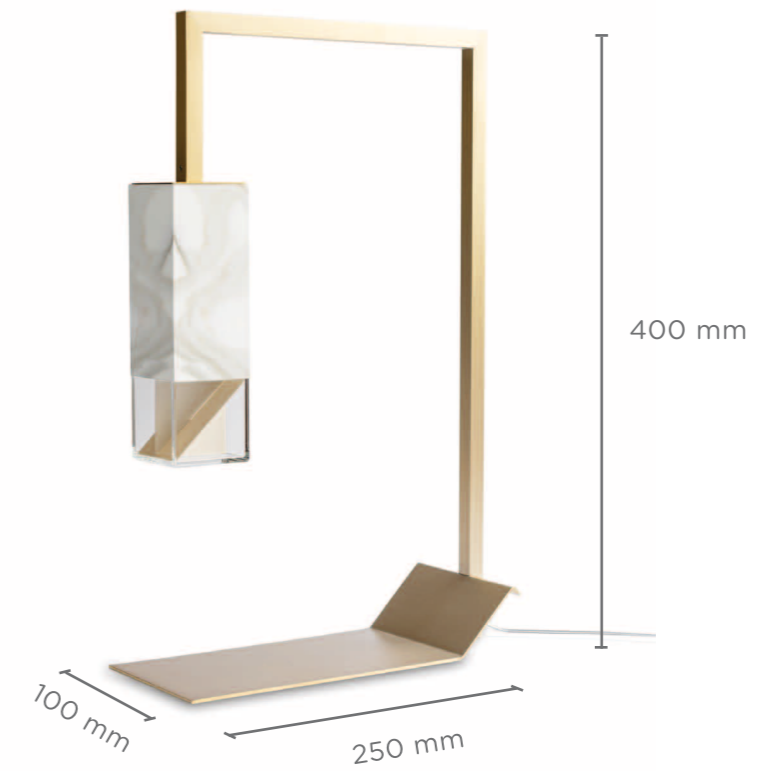

Lamp/Two Wood: Cod. L2-T-WW
Lamp/Two Brass: Cod. L2-T-BS
Lamp/Two Marble: Cod. L2-T-MCC

Decorative table-top light for indoor use

Materials:

Body lamp: handcrafted solid Canaletto walnut, natural oil finish / solid brass, golden satin finish / solid Calacatta marble, translucent, matt finish
crystal diffuser hosting Limoges biscuit-finish porcelain sheets.

Structure: solid brass, golden satin finish

Dimensions: h 400 x 250 x 100 mm
diffuser: 170 x 50 x 50 mm

Light source supplied:
LED 1xG9 max 2.6W, 50-60Hz G9 connection 320lm
2700K Rc 80 EU Standard compliant

Voltage: 220-240v (120v available upon request)

Supplied accessories:

Cable per lamp: 2x0,75 Ø 3mm L 1,2m (transparent switch along the cable and plug included)



LAMP
/TWO
COLOUR EDITION



/TABLE LIGHTS
-
LIMITED
EDITIONS



LAMP
/TWO
RED



LAMP
/TWO
YELLOW

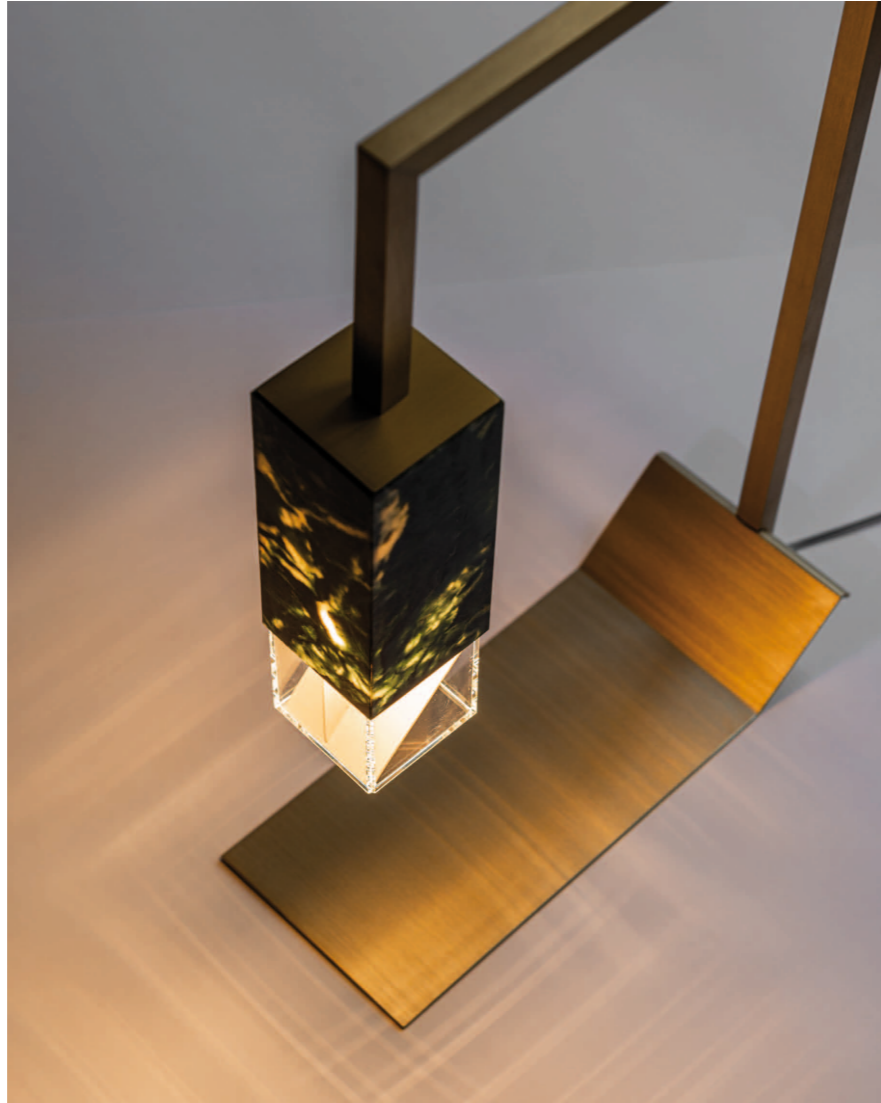

LAMP
/TWO
-
GREEN
-
TRANSLUCID MARBLE
DIFFUSER

LAMP
/TWO
REVAMP EDITION
01



LAMP
/TWO
BRASS RE01
-
BURNISHED BRASS,
BRUSHED MATT FINISH



LAMP
/TWO
WOOD RE01
-
WALNUT BRIARWOOD



LAMP
/TWO
MARBLE RE01
-
ARABESCATO OROBICO
GREY & ORANGE MARBLE



LAMP
/TWO
-
BRASS RE02
-
BURNISHED BRASS,
MATT SATIN FINISH



LAMP
/TWO
-
WOOD RE02
-
OLIVE BRIARWOOD



LAMP
/TWO
-
MARBLE RE02
-
PALISSANDRO BLU
NUVOLATO

LAMP
/TWO
REVAMP EDITION
02

/TECHNICAL
SPECIFICATIONS

LAMP
/TWO
COLOUR EDITION

RED
GREEN
YELLOW

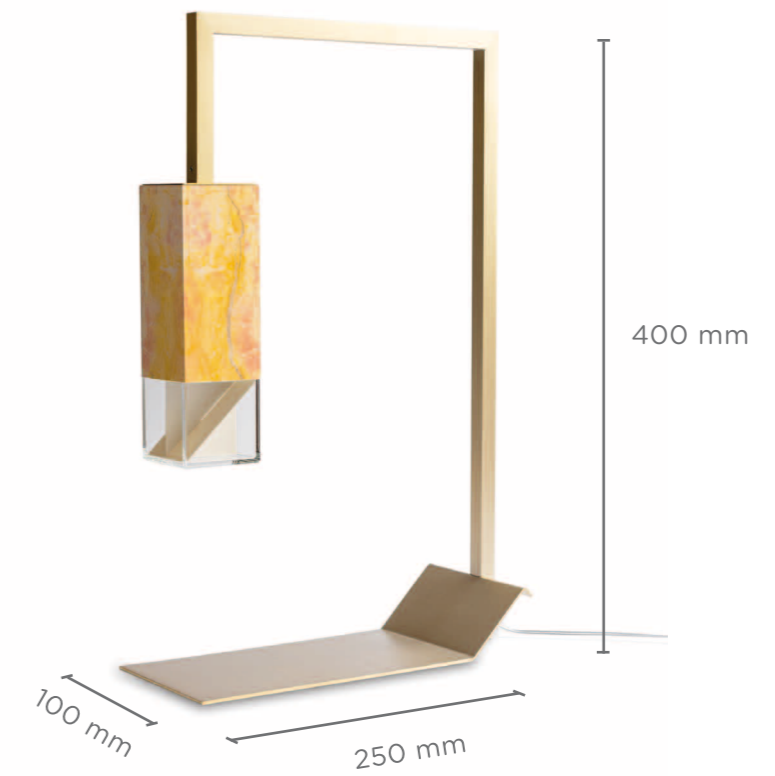

Lamp/Two RED: Cod. L2-T-RED
Lamp/Two GREEN: Cod. L2-T-GREEN
Lamp/Two YELLOW: Cod. L2-T-YELLOW

Decorative table light for indoor use

Materials:

Body Lamps: handcrafted solid marble Red Collemantina / translucent Green Alpes / translucent Royal Pink Yellow crystal glass diffuser, hosting Limoges biscuit-finish porcelain sheets.

Structure: solid brass, satin golden finish.

Dimensions: H 400 x 250 x 100 mm
diffuser: 170 x 50 x 50 mm

Light source supplied per lamp:
LED 1xG9 max 2.6W, 50-60Hz G9 connection 320lm
2700K Rc 80 EU Standard compliant

Voltage: 220-240v (120v available upon request)

Supplied accessories:

Cable per lamp: 2x0,75 Ø 3mm L 1,2m (transparent switch along the cable and plug included)

/TECHNICAL
SPECIFICATIONS

LAMP
/TWO
REVAMP EDITION
01
02

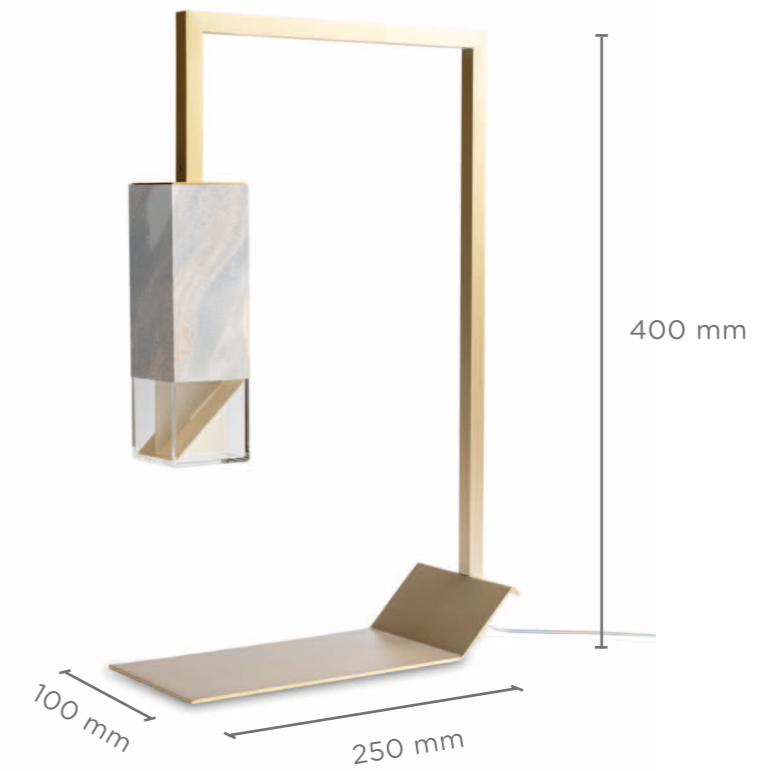

Revamp Edition 01

Lamp/Two Wood: Cod.L2-T-WRE01
Lamp/Two Brass: Cod. L2-T-BRE01
Lamp/Two Marble: Cod. L2-T-MRE01

Materials:

Body lamp: handcrafted solid walnut briarwood, matt oil finish / solid burnished brushed brass / solid Arabescato orobico grey & orange marble, crystal diffuser hosting Limoges biscuit-finish porcelain sheets.

Revamp Edition 02

Lamp/Two Wood: Cod.L2-T-WRE02
Lamp/Two Brass: Cod. L2-T-BRE02
Lamp/Two Marble: Cod. L2-T-MRE02

Materials:

Body lamp: handcrafted solid olive briarwood, matt oil finish / solid burnished satin brass / solid Palissandro Blu Nuvolato marble, crystal diffuser hosting Limoges biscuit-finish porcelain sheets.

(Light source supplied, voltage, accessories see page 51)

/TECHNICAL
SPECIFICATIONS



LAMP
/TWO

BLACK EDITION

Lamp/Two BLACK: Cod. L2-T-BLACK

Decorative table light for indoor use

Materials:

Body Lamps: handcrafted solid black Portoro Gold vein marble, crystal glass diffuser, hosting Limoges biscuit-finish porcelain sheets.

Structure: solid brass, satin golden finish.

Dimensions: H 400 x 250 x 100 mm
diffuser: 170 x 50 x 50

Light source supplied per lamp:
LED 1xG9 max 2.6W, 50-60Hz G9 connection 320lm
2700K Rc 80 EU Standard compliant

Voltage: 220-240v (120v available upon request)

Supplied accessories:

Cable per lamp: 2x0,75 Ø 3mm L 1,2m (transparent
switch along the cable and plug included)

DÉCOR/S COLLECTION
-
LIMITED
EDITIONS

MIRROR/ZERO
COLLECTION

The *Mirror/Zero Collection* reinterprets and reframes the concept of a wall mirror, emphasising its décor statement function within the Interior lexicon. As a result, the cutting-edge aesthetic of this new series plays with the fading reflections of the subject, creating a *trompe-l'oeil* effect and indissolubly blending the objective and subjective dimensions through extra-thin material layers.

The careful selection of materials: hand-ground bronze or dark-grey crystal, walnut briarwood, solid marbles and brass, features a mirror gradient, thanks to an innovative experimental craft technique of surfaces layering. Furthermore, together with a frameless and sleek appearance, a faint tilt provides a further twist in the subject perception, increasing the engagement and highlighting the thinness and lightness of this unexpected two-dimensional composition.



MIRROR/ZERO
BLACK EDITION

MIRROR/ZERO
REVAMP EDITION 01



MIRROR/ZERO
FADING BRASS
RE01



MIRROR/ZERO
FADING MARBLE
RE01

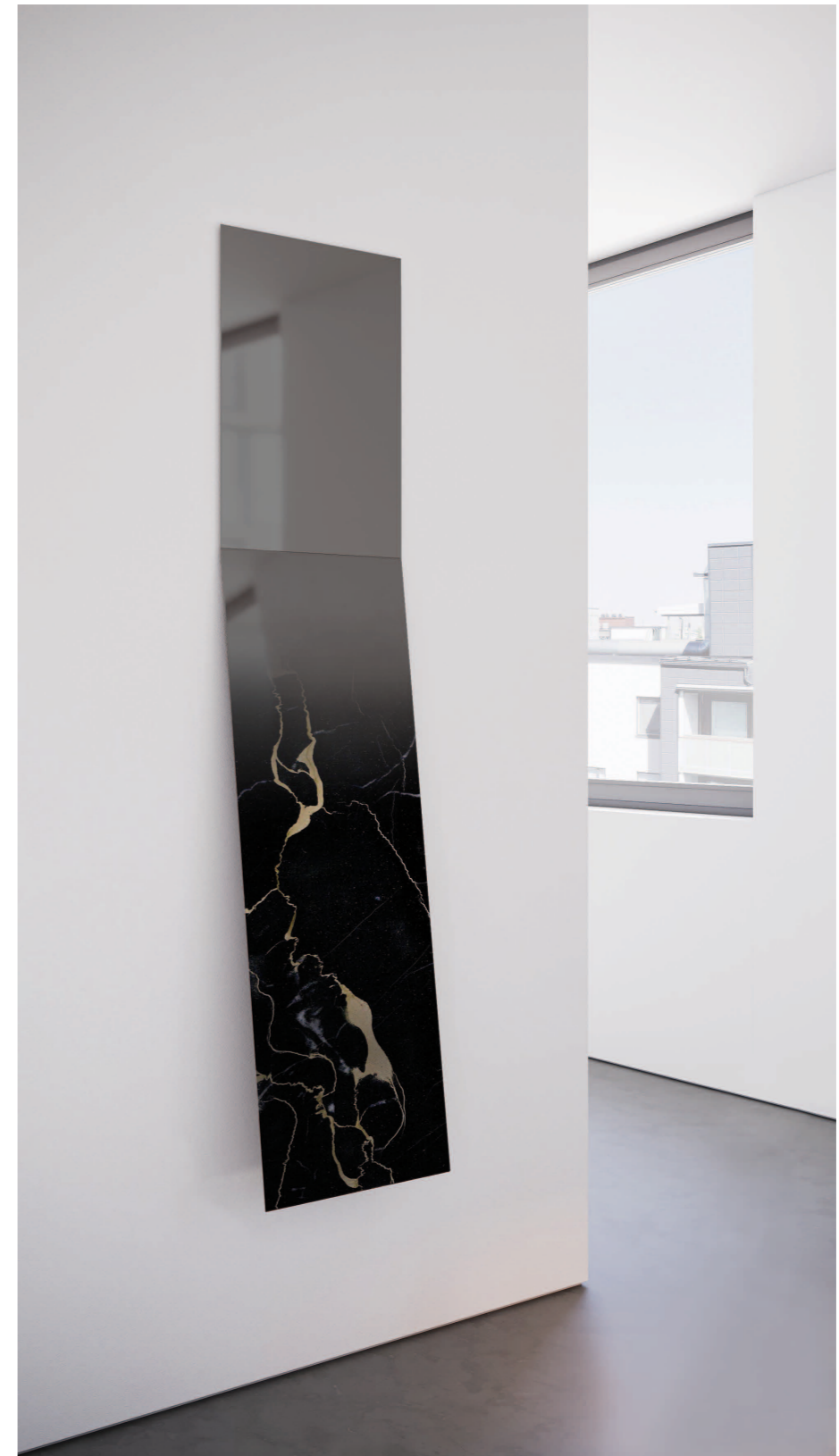

/TECHNICAL
SPECIFICATIONS

MIRROR
/ZERO
FADING MARBLE
FADING BRASS
REVAMP EDITION 01

Mirror/Zero Fading Marble: Cod. M0-W-MRE01
Mirror/Zero Fading Brass: Cod. M0-W-BRE01

Indoor decorative wall mirror handmade in Italy

Materials:

Extra-thin solid *Palissandro Blu Nuvolato* marble, hand-ground crystal layering with mirror shade finish applied by hand /Burnished solid brass, polished finish shade hand-applied

Flush wall metal brackets

Dimensions: h 157,5 x 35 x 0,5 cm
tilt 8°

Made to order

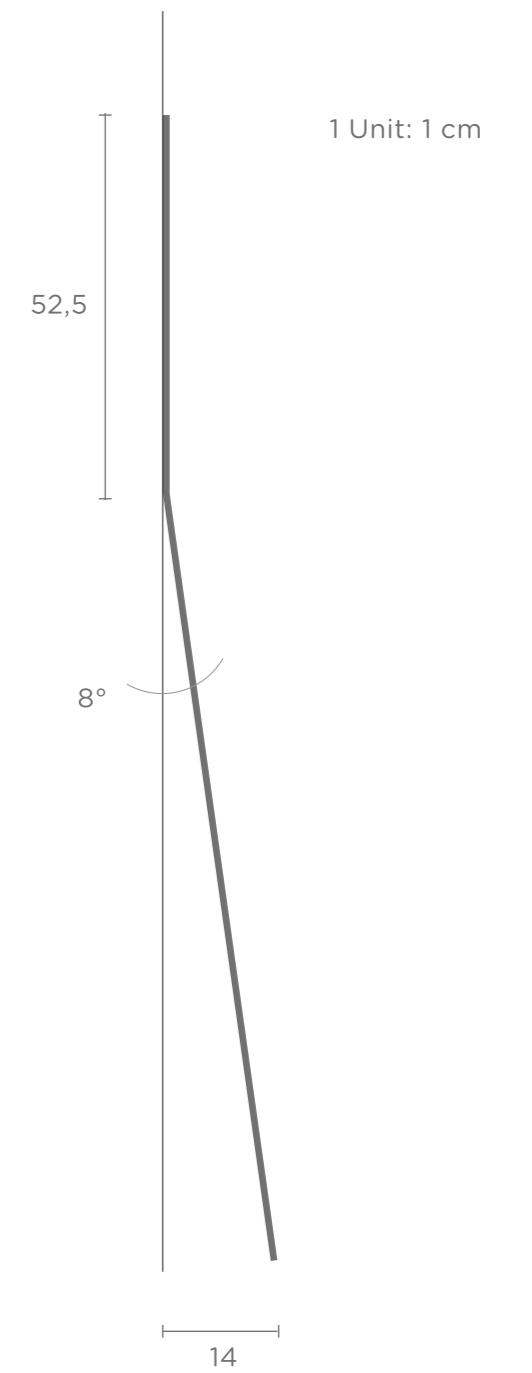
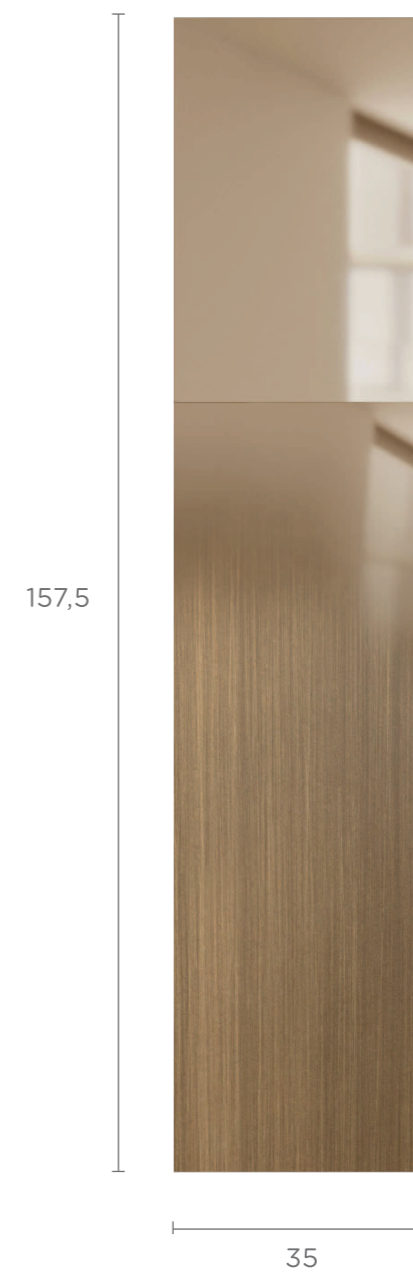

/TECHNICAL
SPECIFICATIONS

MIRROR
/ZERO
FADING WOOD
REVAMP EDITION 02

Mirror/Zero Fading Wood: Cod. M0-W-WRE02
Indoor decorative wall mirror handmade in Italy

Materials:

Walnut briarwood blend with bronze hand-ground crystal layering, mirror shade finish applied by hand

Flush wall metal brackets

Dimensions: h 157,5 x 35 x 1,2 cm
tilt 8°

Made to order

157,5



35

52,5

8°

1 Unit: 1 cm



14

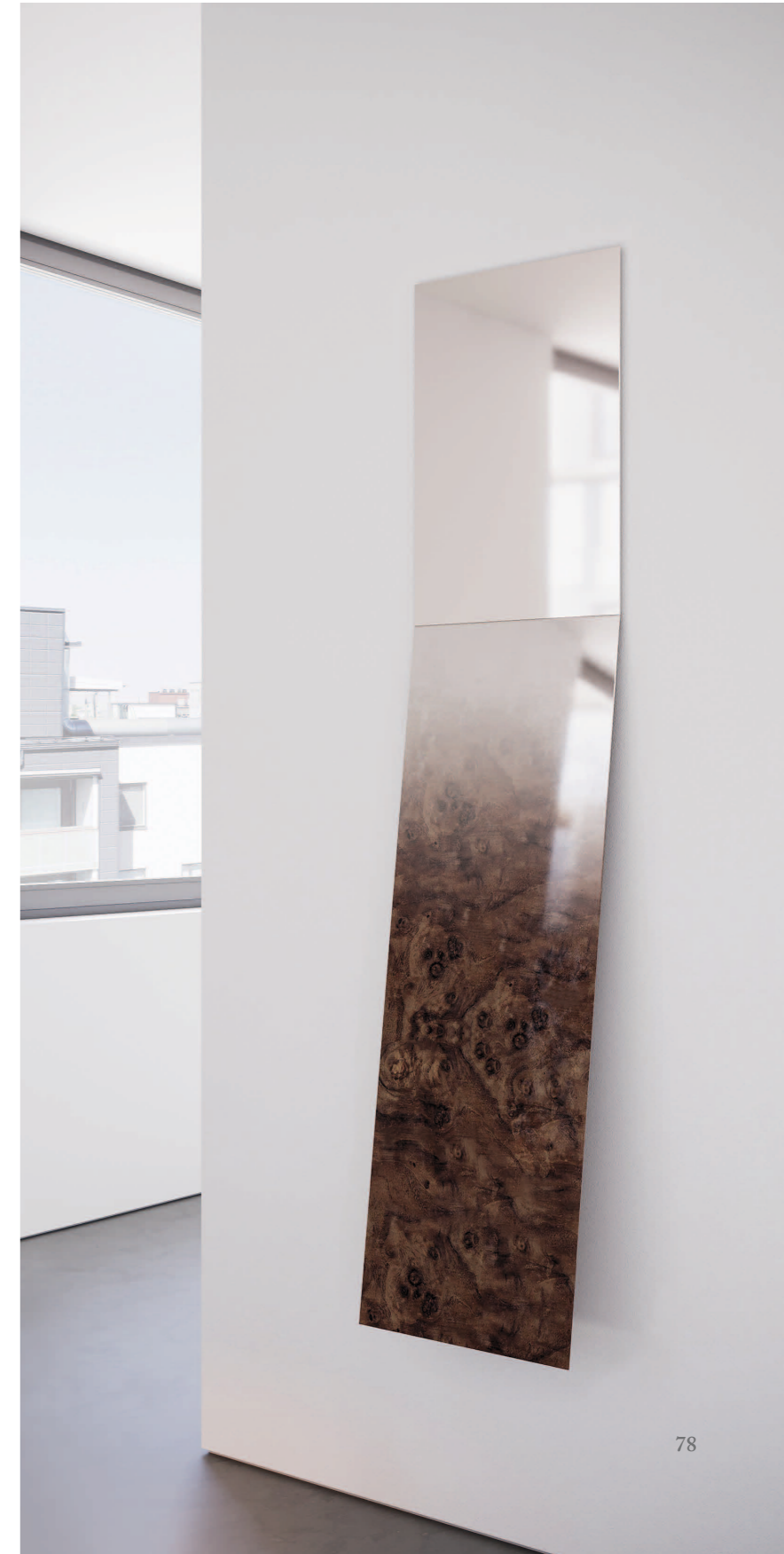

/TECHNICAL
SPECIFICATIONS

MIRROR
/ZERO
BLACK EDITION

Mirror/Zero BLACK: Cod. M0-W-BLACK

Indoor decorative wall mirror handmade in Italy

Materials:

Extra-thin solid black Portoro Gold vein marble, hand-ground dark-grey crystal layering with mirror shade finish applied by hand

Flush wall metal bracket

Dimensions: h 157,5 x 35 x approx. 0,5 cm
tilt 8°

Made to order

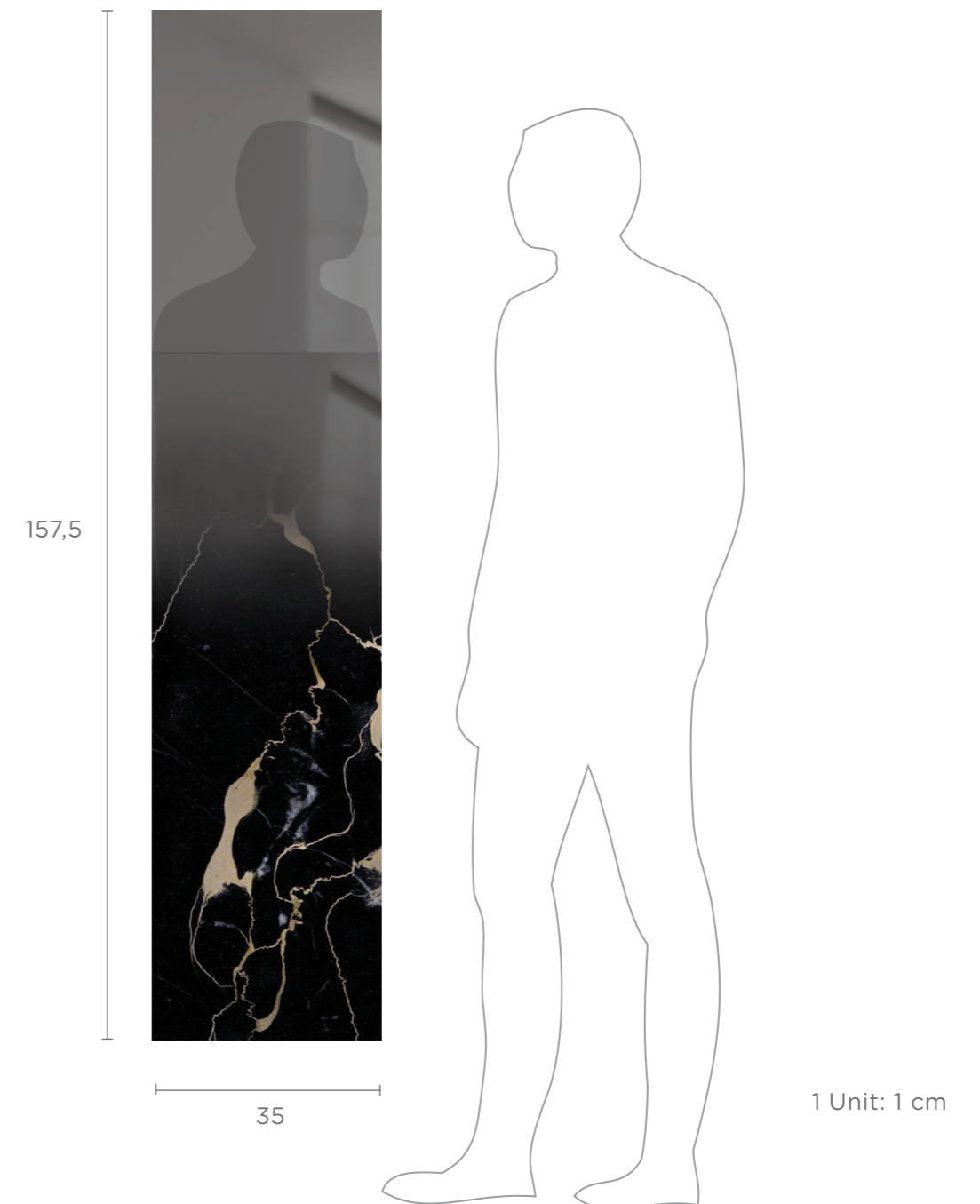

DÉCOR/S COLLECTION
-
OPEN
EDITIONS

CURIOSITÉ
DÉCOR BOXES
COLLECTION

*"THE POINT
ON THE CELESTIAL SPHERE
VERTICALLY ABOVE THE OBSERVER"*



CURIOSITÉ
DÉCOR BOXES
COLLECTION

The *Curiosité Collection* is inspired by imaginary scenarios, playing with the several reflections of crystal glass surfaces, masterly handcrafted and enriched by sought-after mirror shade finish. These minimalist and plain volumes invite the observer to pursue more than one preferred point of view, on the hunt for that perfect intersection where shapes, translucent surfaces and mirror finishes provide an unexpected *Trompe-l'oeil* effect; creating a visual continuity where the objects of this composition blend flawlessly and disruptively.

ZENITH
DÉCOR BOXES SET



CURIOSITÉ
-
SUNRISE
ZENITH & DAZZLE

Sunrise, Zenith and Dazzle are part of the *Décor Boxes* series, representing the multiple variations of the abstract merge between the minimalist volumes tidily arranged on a squared tray and the imaginary solar rays which touch these latter.

In the attempt to conceptualise the light cast by a nordic sunrise, by the zenithal rays of a mid-day of summer, or the dazzle of the blue sea on a sunny afternoon at the beach. In this series, these imaginary rays are formally transposed into mirror shades, rigorously applied by hand on each piece, with a final effect able to twist the initial perspectives hierarchy and, by subtraction, draw the attention where the crystal translucency remains untouched by the mirrored hue.

"THE DAZZLE

OF THE CHOPPED SEA

ON A SUNNY AFTERNOON AT THE BEACH"



DAZZLE

DÉCOR BOXES SET



DAZZLE
CURIOSITÉ COLLECTION



SUNRISE
DÉCOR BOXES SET



*"THE RISE
OF THE SUN
ABOVE THE HORIZON"*



SUNRISE
DÉCOR BOXES SET

/TECHNICAL
SPECIFICATIONS

CURIOSITÉ
DÉCOR BOXES
COLLECTION

Zenith: Cod. CC-DB-ZENITH
Dazzle: Cod. CC-DB-DAZZLE
Sunrise: Cod. CC-DB-SUNRISE

Decorative table boxes set handmade in Italy

Materials:

Zenith: Handcrafted grey crystal glass, dark grey mirror finish gradient

Dazzle: Handcrafted light pink crystal glass, pink mirror finish gradient

Sunrise: Handcrafted transparent crystal glass, silver mirror finish gradient

Dimensions:

Each set is made of 3 Boxes with lids and 1 Plate
Box 1: H 50 x L 105 x D 50 mm - Box 2: H 50 x L 50 x
D 50 mm - Box 3: H 150 x L 50 x D 50 mm
Plate: H 3 x L 210 x D 210 mm

Boxes are laid off at the centre of the plate with 5 mm space between each other, they are removable

Customization available:

engraved initials (price upon request)

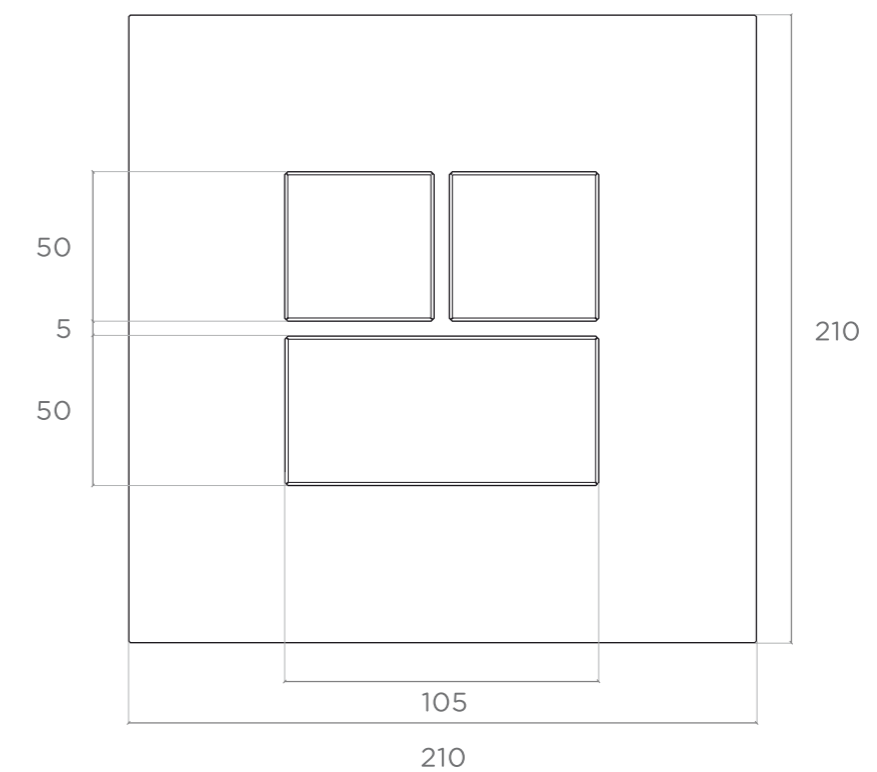
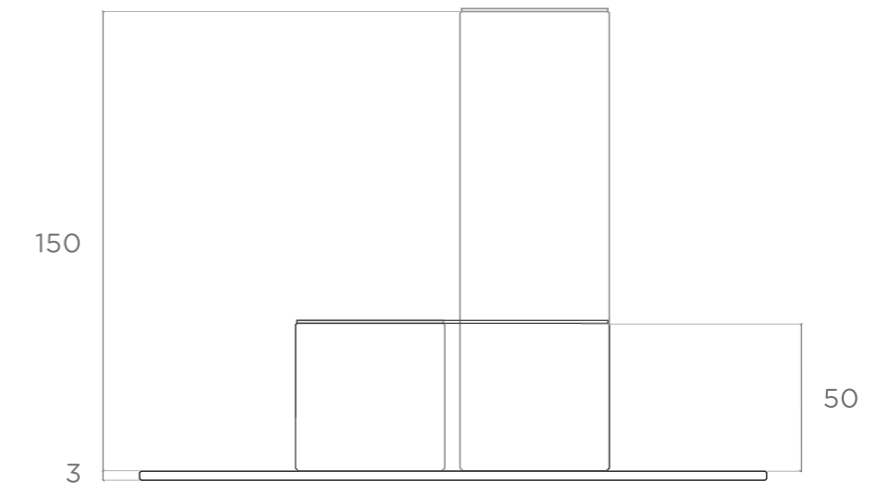

1 Unit: 1 mm

ZENITH

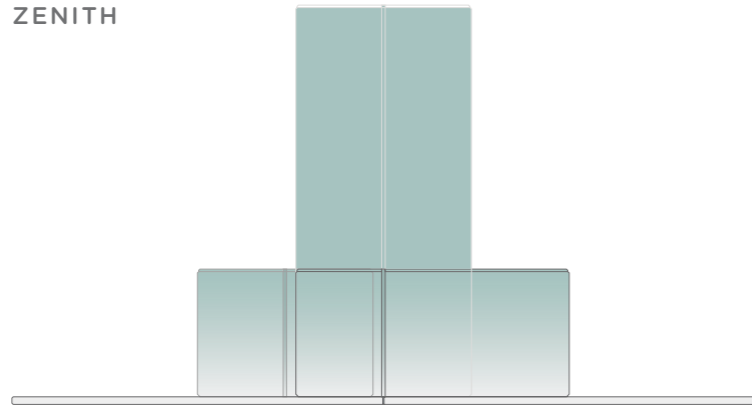

DAZZLE

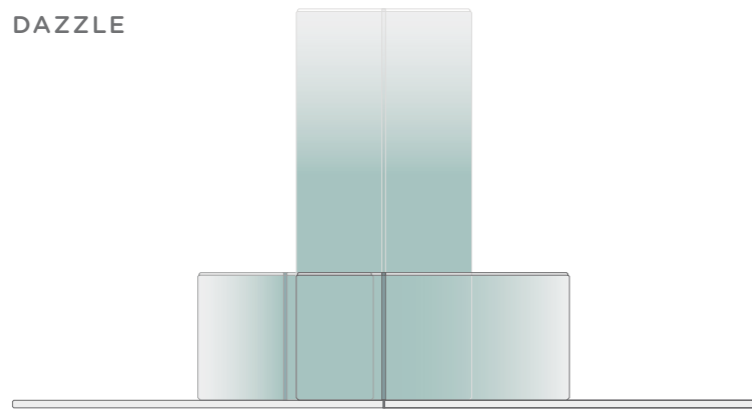

SUNRISE

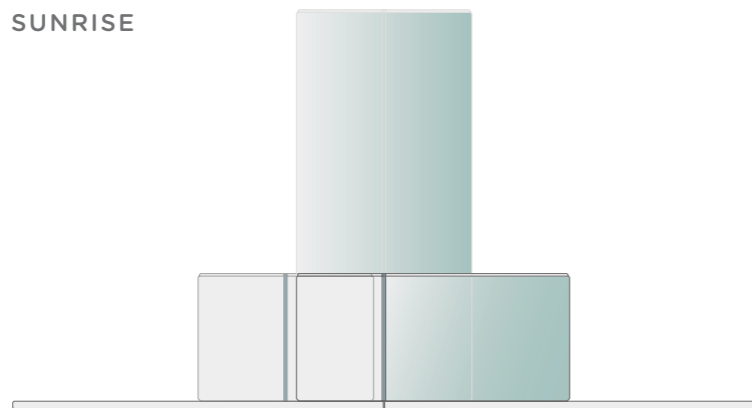

■ crystal glass

■ mirror shade



/CONTACTS

www.formaminima.com

info.formaminima@gmail.com

Trieste, Italy



pinterest.com/formaminima [@_formaminima_](https://www.instagram.com/_formaminima_) facebook.com/formaminima

Lamp/s & Décor/s Collection Catalogue 2023

Design, art direction and editorial realization:

Formaminima-Trieste

Photographic references:

© 2022 Formaminima

© 2022 Davide Maria Palusa

Pages: 2,3,6,8,9-10, 20, 28, 33, 36, 38,
39-40, 49-50, 53-54, 56, 57-59

Printing, bookbinding: Tipografia Marioni (UD)

No part of this catalogue can be reproduced
or transmitted in any form or by any electronic, mechanical
or other means without the written permission of the rights
owners.

© 2022 Formaminima by Caterina Vrabec
Via G.Ciamician 6, 34124, Trieste
REA: TS-202475, C.F: VRBCN90A49L424Y
VAT N: 01307530327