

News book

2019

**Nb**

mdf italia

Novelties for living  
and office



**mdf italia**

Minima 3.0	34
Sketch	
Room Divider	
Sideboard	
Qubit	44
Super_Position	50
Flow Textile	56
Flow Leather	62
Flow Filo	68
Aïku stool	74
M1 color	78
Rock Table	82
Tense	86
Diamond	
Fine Wood	
Low table	
Outdoor	
Tense Curve	94
S Table	98
Metodo	102
20.Venti Home	106
20.Venti system	112
Neil Basic	116
Neil Twist	120
Mirror Lines	124

A newly conceived newsbook, to describe MDF Italia's latest products: brand new products, icons that change and transform, all of them featuring a simplicity that, together with essentiality and elegance, are MDF Italia's hallmarks.

A visual tale based on few signs and discreet presences. "Alluded", never showy living spaces, where balance, rigour and silence stand out. There are few objects in the domestic scenarios evoked by this catalogue, in a harmonious dialogue of shapes and finishes. Highlighted objects are well selected such as felt carpets, iconic lamps, books, skittles, but also terracotta sculptures reminding architectonic and mechanical elements.

An intentional abstraction, that leaves room for imagination and that allows to spontaneously adapt MDF Italia's products to our personality and spaces. The typographic layout, the product sheets and the rhythm feature a language based on pureness and essentiality, perfectly in tune with MDF Italia's collection and philosophy.

L'essenza di MDF Italia raccontata attraverso nuovi prodotti molto diversi tra loro, per forma e funzione, ma che hanno in comune forti caratteristiche identitarie: linee geometriche ed equilibrio compositivo.

Un News Book di nuova concezione, per raccontare le ultime novità di MDF Italia: prodotti inediti, icone che mutano e si trasformano, tutte caratterizzate da quella semplicità che, assieme all'essentialità e all'eleganza rappresentano i tratti distintivi di MDF Italia.

Un racconto visivo costruito su pochi segni e presenze misurate. Ambienti abitativi "suggeriti" e mai ostentati, in cui spiccano equilibrio, rigore e silenzio.

Pochi gli oggetti negli scenari domestici evocati dal catalogo, in un dialogo armonico di forme e finiture, ma quelli presenti sono ben selezionati come i tappeti in feltro, le lampade iconiche, i volumi, i birilli, ma anche le sculture in terracotta che ricordano elementi architettonici e meccanici.

Un'astrazione voluta, che vuol lasciare immaginare e che permette di pensare e adattare con spontaneità i prodotti MDF Italia alla propria personalità e ai propri spazi. Il layout tipografico, le schede tecniche e il ritmo denotano un linguaggio basato su purezza ed essentialità in perfetta sintonia con la collezione e la filosofia MDF Italia.

mdf Italia's essence described through new products that are so different from one another in terms of shape and function, but that have in common a few hallmarks: geometrical lines and compositional balance.



Neil Twist armchair  
L75.2 D66 H71  
seduta / seat H41.3

Metodo coffee table  
Ø40 H30, Ø50 H40

Minima 3.0 Sketch  
composizione / composition MS-5  
L360 D33 H41.5

Cosy sofa system  
L370 D275 H70

Minima 3.0 Sideboard  
composizione / composition SB-4  
L366 D39 H100

STable  
Ø 156 H73

Flow Chair Color  
base a stelo / central leg  
L53 D54 H80.5  
seduta / seat H44

Neil Twist armchair  
L75.2 D66 H71  
seduta / seat H41.3



Minima 3.0 Sideboard  
composizione / composition SB-4  
L366 D39 H100

S Table  
Ø 156 H73

Flow Leather Chair  
base a stelo / central leg  
L53 D54 H80.5  
seduta / seat H45



Yale Bed  
L220 D200 H103

Metodo coffee table  
Ø50 H40

Mirror Lines  
composizione / composition 6  
L32 D5 H140

Mirror Lines  
composizione / composition 5  
L12 D5 H145

Inmotion modular system  
L144, L85 D48 H32

Qubit bookcase  
L63 D46 H66.5, H90.5

Neil basic  
L78 D67 H69.5  
seduta / seat H41



Yale Bed  
L220 D200 H103  
Metodo coffee table  
Ø50 H40



Neil basic  
L78 D67 H69.5  
seduta / seat H41

Super\_Position bookcase  
composizione / composition I  
L275 D40 H204.2

Metodo coffee table  
Ø40 H30





Yale X sofa  
L250 D86 H80

Tense Material low table  
L90 D90 H35

Qubit bookcase  
L63 D46 H161.5

Tense Curve  
L140 D140 H73

Flow Textile Chair  
VN 4 gambe rovere / oak VN 4 legged  
L56 D56 H80.5  
seduta / seat H44

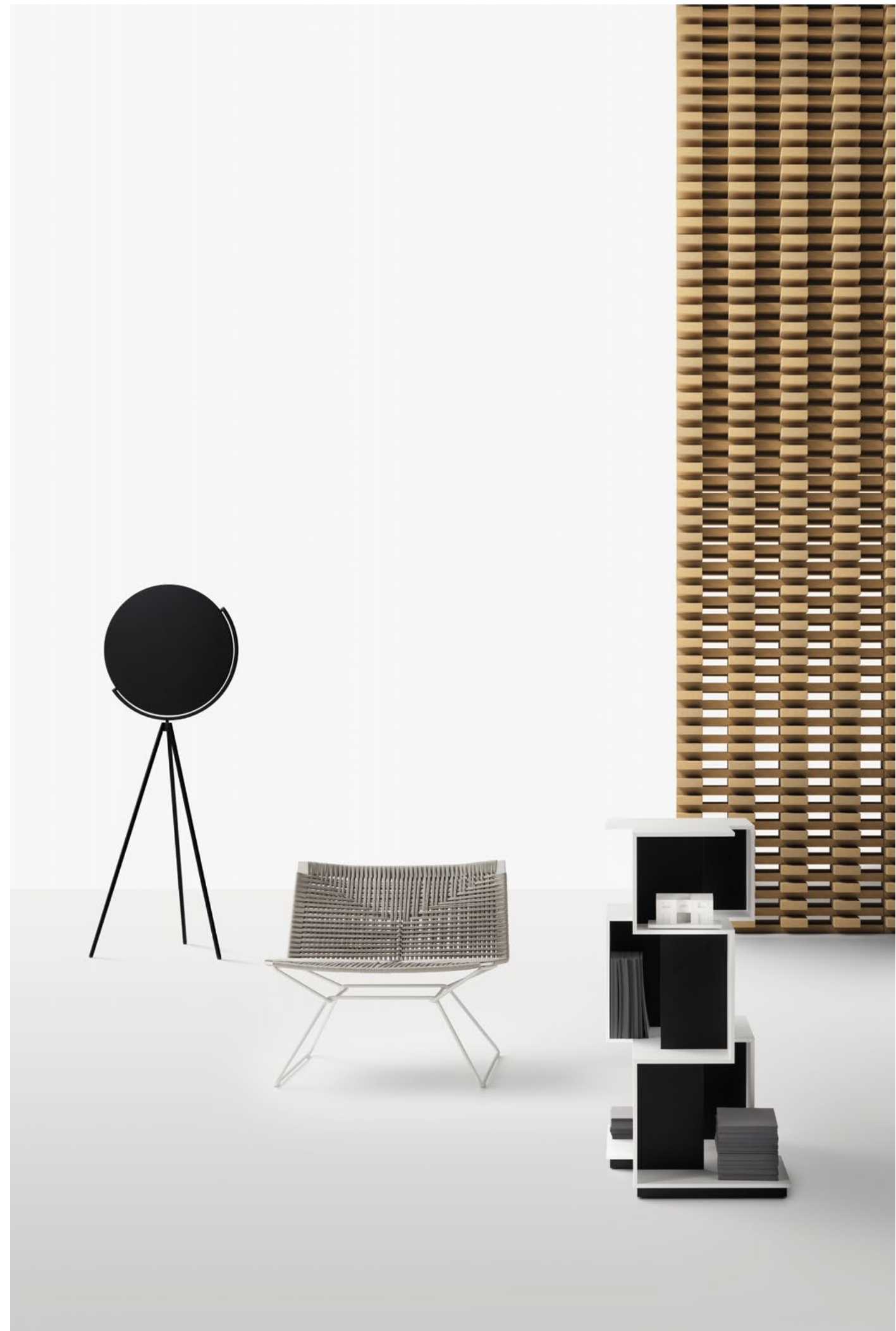





Minima 3.0 system  
elettrificata / electrified  
L243 D33 H188,5

Flow Leather Slim  
base a stelo / central leg  
L55 D54 H76,4  
seduta / seat H44

Tense Material Fine Wood  
L300 D100 H73









# Novelties



Aiku stool  
base a slitta / sled base  
L61 D55 H96

20.Venti High Workstation  
L200 D100 H110



# Minima 3.0 Sketch Room Divider Sideboard

By Metrica  
design Bruno Fattorini

Oggi Minima 3.0 si evolve e si rinnova, trasformandosi in un sistema d'arredo ancora più versatile e adattabile, capace di unire più funzioni. La nuova Minima 3.0 si suddivide in cinque tipologie: a terra, pensile, sketch, sideboard e room divider. Ulteriore novità: mensole con integrazione di luci a led e due nuove finiture grigio ombra e nichel perla.

Minima 3.0 Sketch, è una collezione di composizioni pensili dinamiche e dal notevole impatto estetico, che si presta a diverse interpretazioni e funzioni. Un disegno sulla parete che movimentata la superficie, rendendo unico lo spazio che lo ospita. Disponibile in 10 composizioni predefinite in svariate lunghezze e altezze.

Minima 3.0 Sideboard, è una collezione di madie funzionali, da utilizzare sia come divisorio che come elemento a muro, per la zona giorno o per l'area notte. La madia separa, contiene e ospita, conferendo ritmo allo spazio. Disponibile in otto composizioni predefinite, due altezze e in svariate lunghezze.

Minima 3.0 Room Divider è un sistema divisorio di grande flessibilità, che può raggiungere i 3 metri di altezza. Nata per separare, divide in modo funzionale sia gli spazi residenziali che professionali, favorendo così lo smart working. Dunque, non è solo una libreria, ma un vero e proprio sistema versatile adatto a differenti usi, in linea con l'epoca veloce e multitask del web. Una soluzione d'arredo dallo stile minimale e carismatico, che amplia le proprie opzioni di personalizzazione, adattandosi a svariate ipotesi d'uso per venire incontro a differenti esigenze dei fruitori finali. Disponibile in dieci altezze e massimo sei campate.

Today Minima 3.0, evolves and renews, turning into a more versatile and adaptable furnishing system, capable of joining more functions. The new minima 3.0 is divided into five types: ground-resting, hanging, sketch, sideboard and room divider. New shelves with led lights integration and new finishes: pearl nickel and shadow grey.

Minima 3.0 Sketch is a dynamic and eye-catching wall composition collection, lending itself to different functions and interpretations. A design on the wall, a graphic, but highly functional trait. A sketch that makes the surface move, together with its unique surrounding space. Available in ten configurations.

Minima 3.0 Sideboard is a functional and multi-purpose sideboard collection, to be used both as a partition and as a wall element either for the living or the night area. Minima Sideboard separates, contains and gives space a good rhythm. Available in two heights and eight configurations.

Minima 3.0 Room Divider, is an extremely flexible system, which reaches 3 meters in height. It was born to separate, and it divides in a functional way both residential and contract spaces. It's not just a bookcase, but a versatile system suitable for different uses, in line with the fast and multitask era of the web. Thus, a minimal and charismatic furnishing solution, that extends its customisation options, to adapt to different end uses and to meet different customers' needs. The Room Divider version comes in ten heights and max six columns as per compositions.

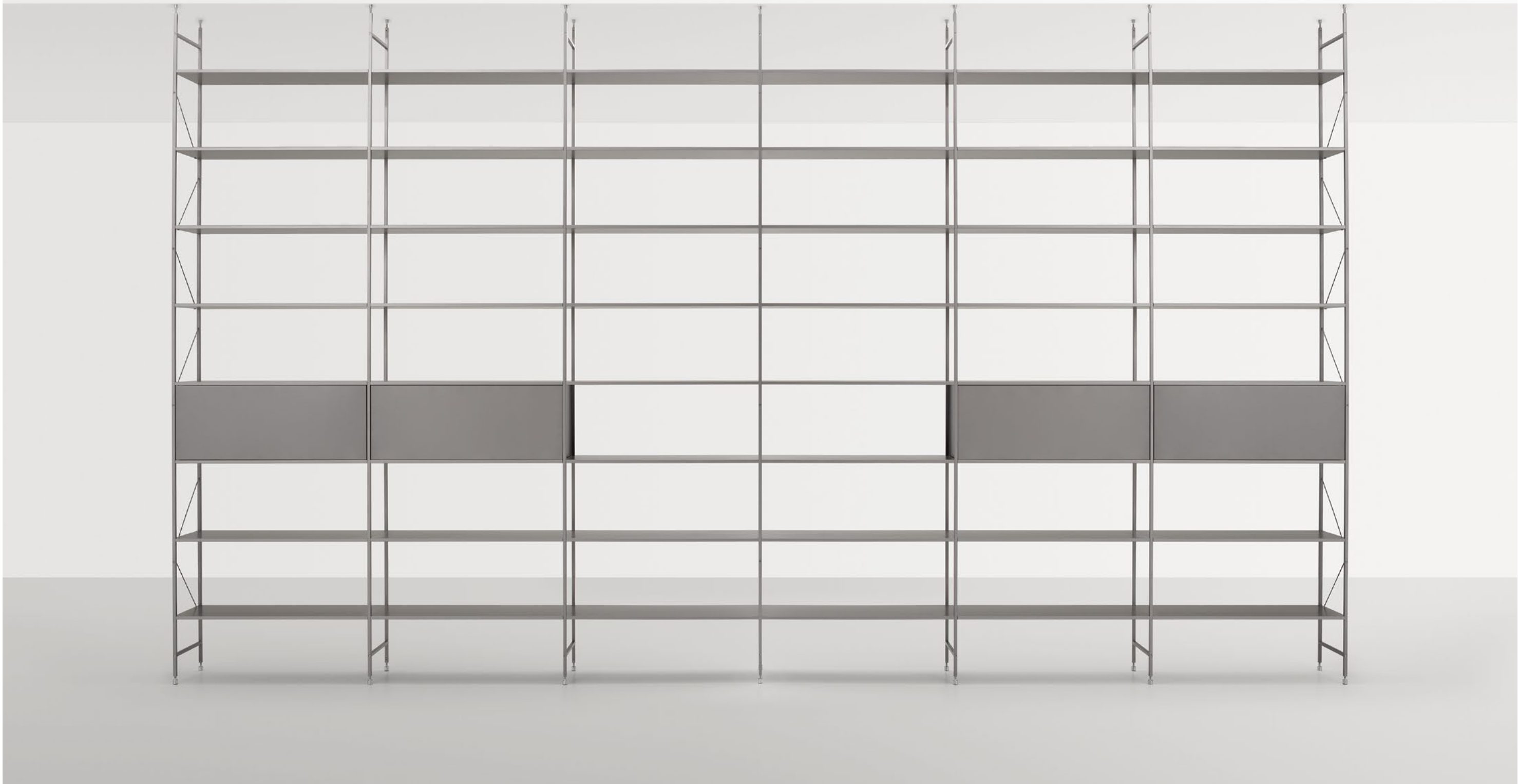



Sideboard  
Dettaglio top materico in marmo ricostruito  
nero ebano / detail of the material top  
in black ebony reconstructed marble



Sideboard  
Composizione / composition SB-2  
Struttura verniciata opaca grigio grafite  
Matt painted graphite grey structure  
L244 D39 H100

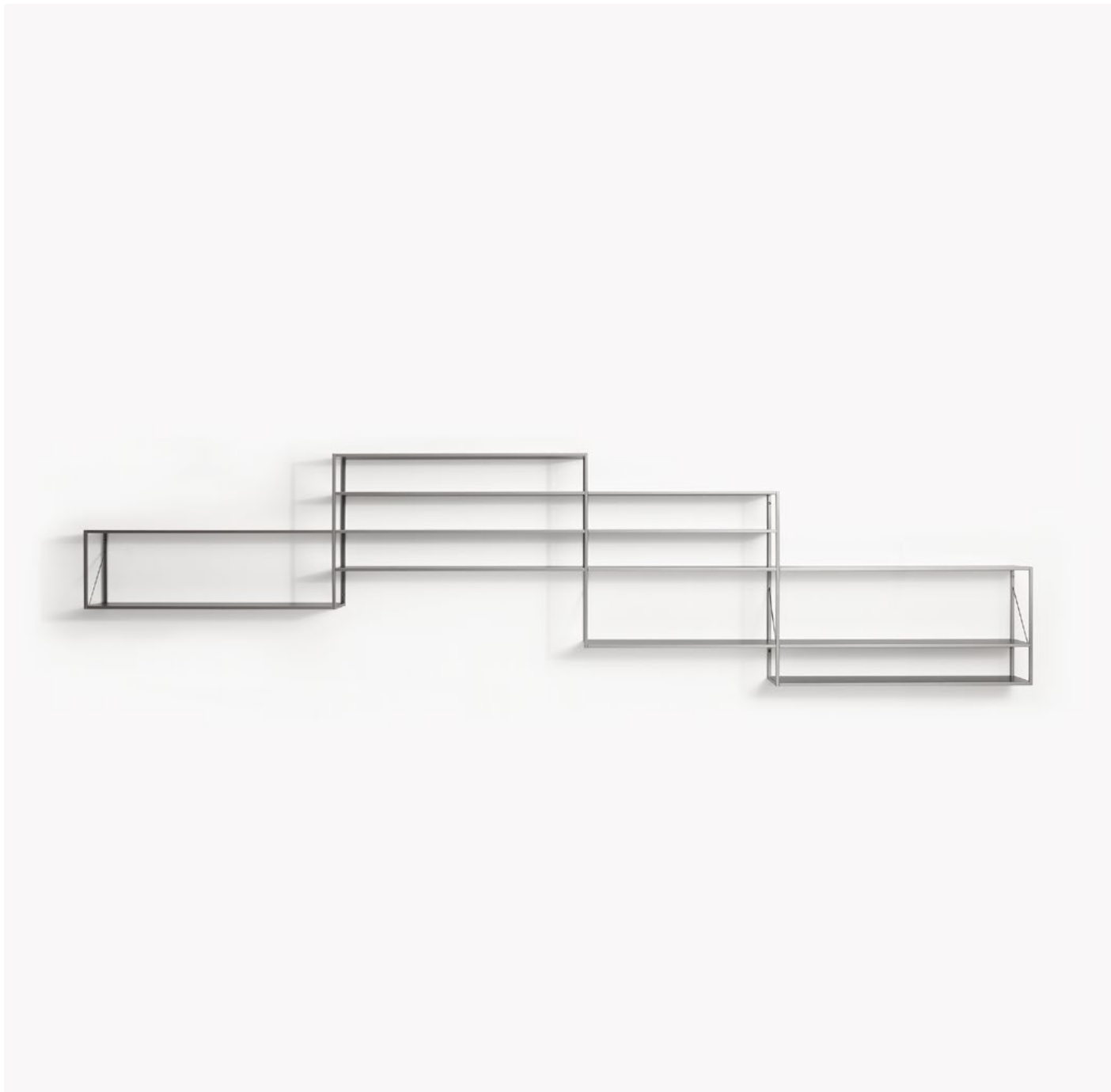

Skeeth  
Composizione / composition S-5  
Verniciata opaca nichel perla  
Matt painted pearl nickel  
L458 D33 H110

Skeeth  
Composizione / composition MS-5  
Struttura verniciata opaca grigio grafite  
top in marmo ricostruito bianco Carrara  
Matt painted graphite grey structure  
material top in white Carrara reconstructed marble  
L360 D33 H41.5



# Sketch

# Sideboard and Room Divider

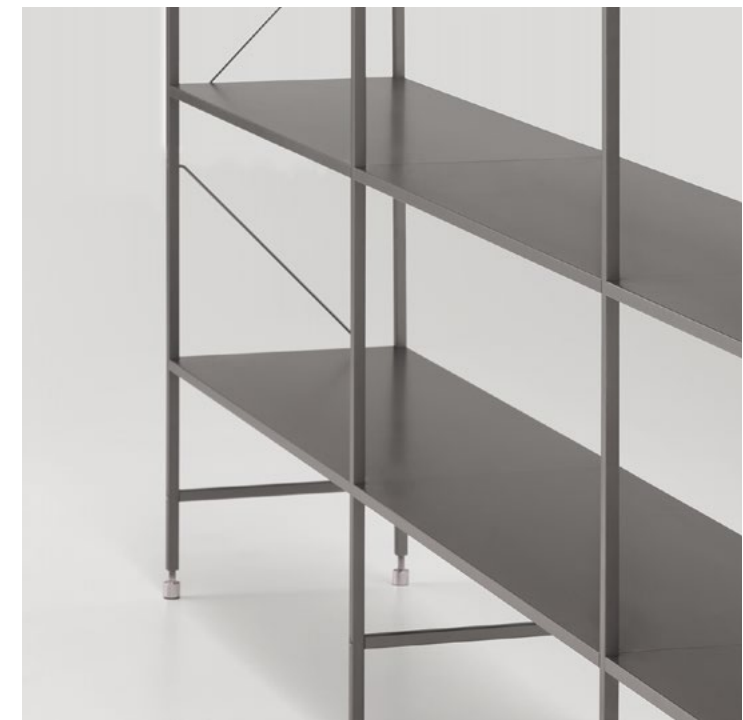

1. Minima 3.0 Skecth, dettaglio top materico in marmo ricostruito bianco Carrara / detail of the material top in white Carrara reconstructed marble.

2. Room Divider, dettaglio struttura verniciata opaca nichel perla / detail of the structure matt painted pearl nickel.

<p>Composition MS-1 L210 D33 H23</p>	<p>Composition MS-2 L240 D33 H23</p>	<p>Composition S-1 L185 D33 H74.5</p>	<p>Composition S-2 L246 D33 H74.5</p>	<p>Composition 1 H 230, 240, 250, 260, 270, 280, 290, 300, 310, 320 L 60, 90, 120</p>	<p>Composition 2 H 230, 240, 250, 260, 270, 280, 290, 300, 310, 320 L 120, 190, 240</p>	<p>Composition SB-1 L184 D39 H100 L184 D39 H64</p>	<p>Composition SB-2 L244 D39 H100 L244 D39 H64</p>
<p>Composition MS-3 L270 D33 H41.5</p>	<p>Composition MS-4 L300 D33 H41.5</p>	<p>Composition S-3 L276 D33 H93</p>	<p>Composition S-4 L368 D33 H110</p>	<p>Composition 3 H 230, 240, 250, 260, 270, 280, 290, 300, 310, 320 L 180, 270, 360</p>	<p>Composition 4 H 230, 240, 250, 260, 270, 280, 290, 300, 310, 320 L 240, 360, 480</p>	<p>Composition SB-3 L276 D39 H100 L276 D39 H64</p>	<p>Composition SB-4 L366 D39 H100 L366 D39 H64</p>
<p>Composition MS-5 L360 D33 H41.5</p>		<p>Composition S-5 L458 D33 H110</p>		<p>Composition 5 H 230, 240, 250, 260, 270, 280, 290, 300, 310, 320 L 300, 450, 600</p>	<p>Composition 6 H 230, 240, 250, 260, 270, 280, 290, 300, 310, 320 L 360, 540, 720</p>	<p>Frame <span style="float: right;">Material shelf</span></p> <p>Cabinet</p>	



# Qubit

Designed by Victor Vasilev

Qubit: un nome che rende omaggio alla teoria quantistica e alla sua unità di misura per una libreria-contenitore caratterizzata da una geometria rigorosa, ma originale e ammaliante.

Il designer ha infatti sviluppato una sequenza fluida per questo complemento, il cui ritmo viene trasmesso dalla ripetizione dei singoli moduli. Dunque rigore e modularità, ordine e forte personalità, flessibilità e precisione s'intrecciano in questo inedito contenitore, fruibile in molti spazi domestici – dal living alla zona notte – sia come divisorio, che come elemento da accostare al muro. Ma anche totem free-standing, una vera e propria "microarchitettura", come la definisce Vasilev, vivibile da entrambi i lati e in tutte le dimensioni.

Qubit: a name that pays tribute to the quantum theory and its unit of measurement, for a storage-bookcase featuring a rigorous, but original and bewitching geometry.

The designer, actually developed a flowing sequence for this furnishing solution, whose rhythm is transmitted by repeating the individual modules. So, rigour and modularity, order and strong personality, flexibility and precision interweave in this brand new storage unit, that can be used in many home spaces – from the living to the night areas – both as a partition and as an element to pull over to the wall. But also as a freestanding "totem", a real "micro-architecture", as Vasilev calls it, to be lived on both sides and in all sizes.



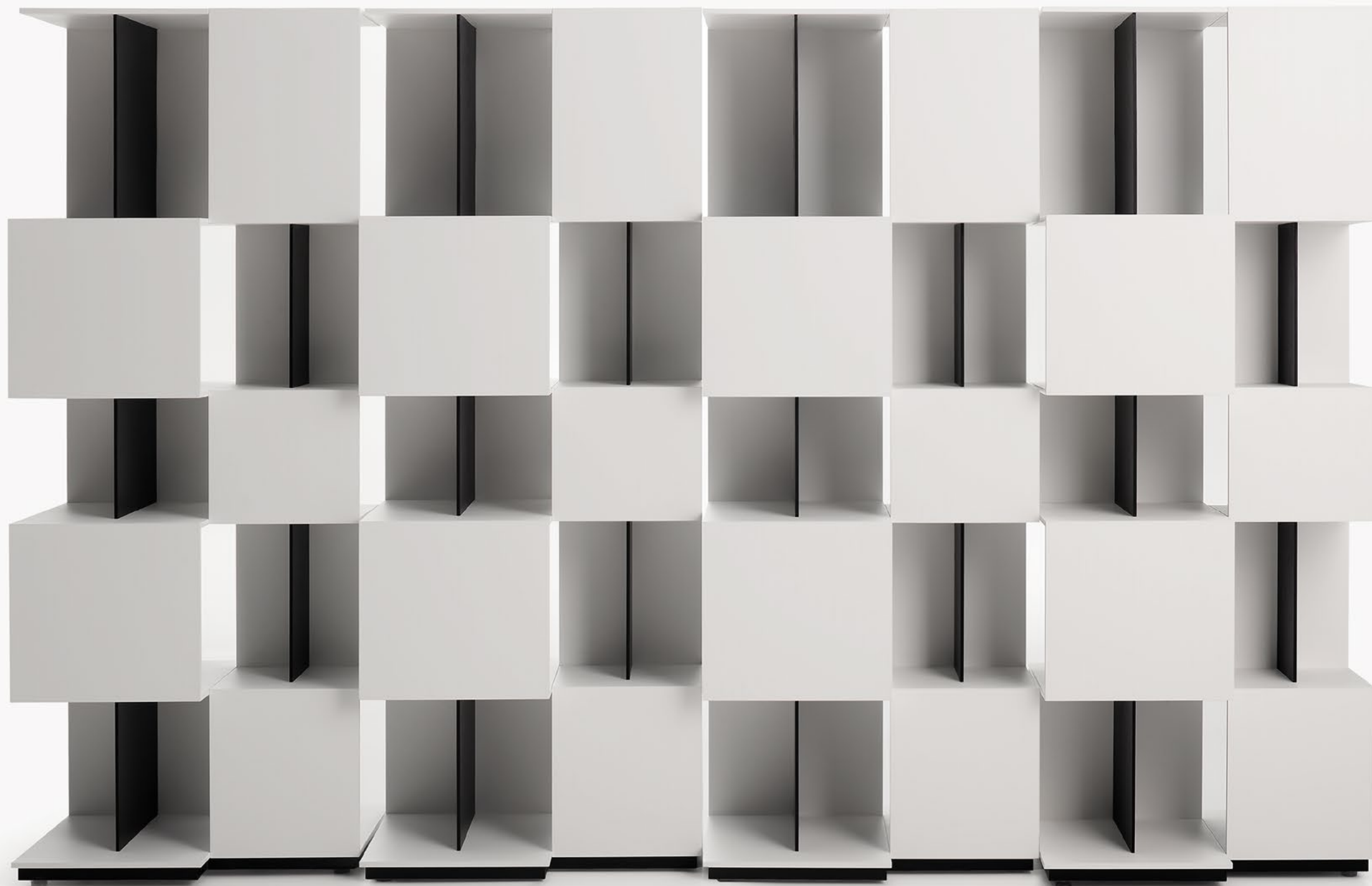

# Micro-architecture



1. Disponibile in due combinazioni sempre a contrasto tra gli elementi / Available in two options, always creating contrast between the elements.



## Modular elements and finishes

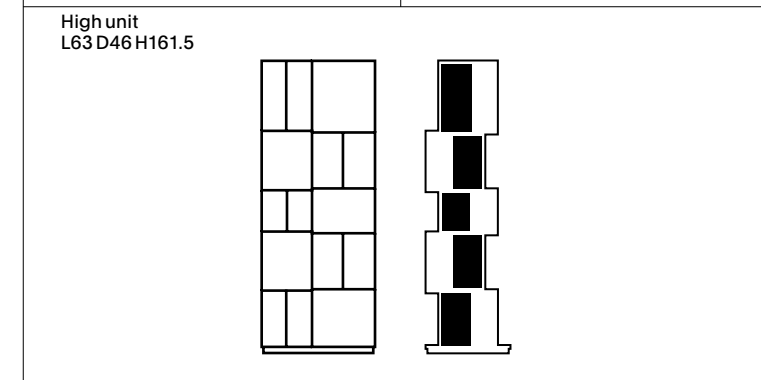
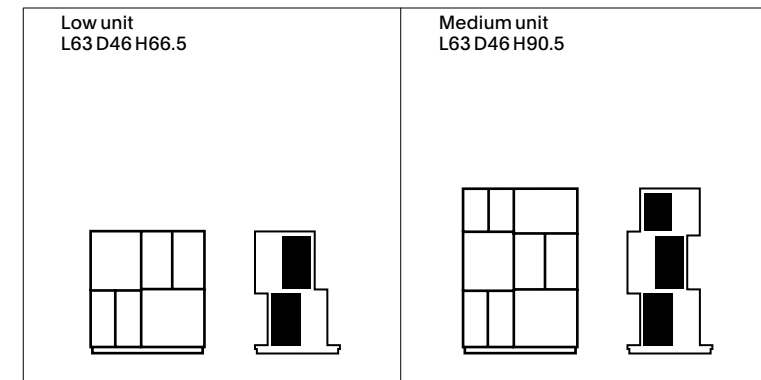

Il contrappeso permette l'utilizzo centrostanza o contro parete / the counterweight allows the installation in the middle of a room or against a wall  
L63 D46 H161.5

# Super\_Position

Designed by Jean Nouvel Design



Leggerezza formale, graficità, semplicità progettuale, estetica armoniosa, essenzialità sono i tratti distintivi di Super\_Position.

Le sovrapposizioni sono un inno alla leggerezza dell'orizzontalità. I piani, attraversati dalla discontinuità delle verticali ininterrotte, sono dei piccoli trampolini che si proiettano nel vuoto circostante.

Gli oggetti, i vasi, le sculture possono esprimere le loro differenze di scala negli spazi vuoti, nelle nicchie al centro o alle estremità delle linee sovrapposte.

Formal lightweight, graphic sign, simple design, harmonious aesthetics, essentiality are the hallmarks of Super\_Position bookcase family.

Overlapped lines are a tribute to the lightness of horizontality. Uninterrupted vertical lines cross the shelves, which extend like small diving boards into the void.

Objects, vases and sculptures can express their differences of scale in empty spaces, in the niches in the middle or on the ends of the overlapped lines.

Verniciata opaca nichel nero e alluminio spazzolato anodizzato naturale  
Matt painted black nickel and natural anodised aluminium

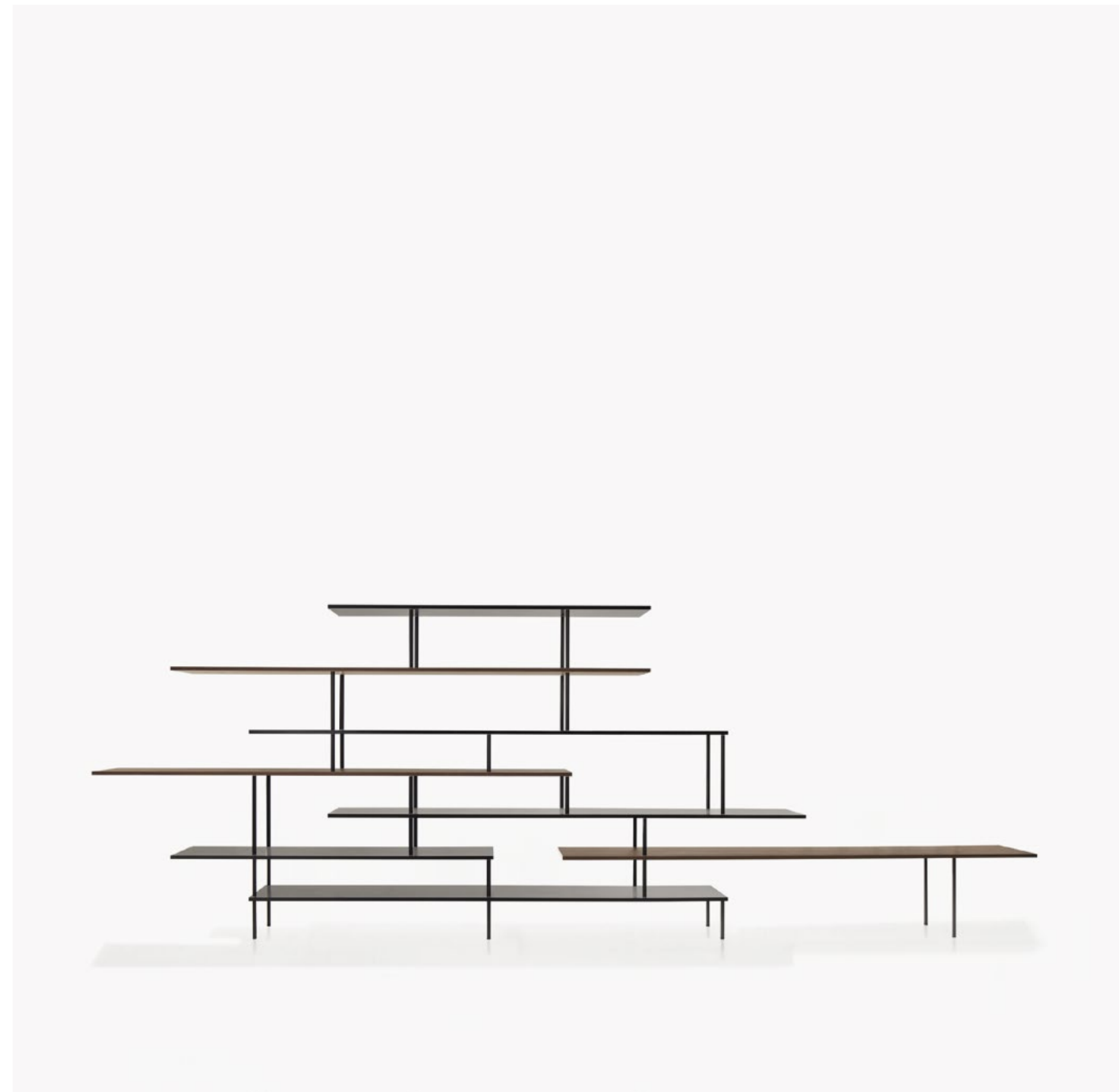

Ripiani dotati di tappo di chiusura in estrusione di alluminio con innesto a pressione  
Shelves equipped with extruded aluminium end caps with push-in connection

Composizione / composition A  
Verniciata opaca nichel nero, mensole in noce canaletto  
Matt painted black nickel, Canaletto walnut shelves  
L545 D40 H192.2



## New wood shelves



1. Mensola in rovere sbiancato  
Bleached oak shelf.



2. Mensola in noce canaletto  
Canaletto walnut shelf.

## Compositions and finishes

<p>Composition A L545 D40 H192.2</p>	<p>Composition B L365 D40 H108.2</p>
<p>Composition C L275 D40 H96.2</p>	<p>Composition D L320 D40 H60.2</p>
<p>Composition E L275 D40 H72.2</p>	<p>Composition F L230 D40 H72.2</p>
<p>Composition G L365 D40 H84.2</p>	<p>Composition H L365 D40 H156.2</p>
<p>Composition I L275 D40 H204.2</p>	<p>Composition J L410 D40 H180.2</p>

Structure and shelf

Wood shelf



Composizione / composition A  
Verniciata opaca nichel nero, mensole in noce canaletto  
Matt painted black nickel, Canaletto walnut shelves  
L545 D40 H192.2

# Flow Textile

Designed by Jean Marie Massaud



A pochi mesi dal debutto a Imm 2019, Flow Textile si conferma una nuova icona di stile, eleganza e comfort nella collezione Flow.

Flow Textile si arricchisce di nuove collezioni tessili dallo stile esclusivo, radicale, elegante e grafico, che protende verso l'universo delle arti grafiche. Questa nuova versione, dal raffinato lavoro di tappezzeria, troverà la sua naturale collocazione in tutti gli spazi soft contract o residenziali.

At the International Furniture Fair in Cologne the iconic Flow collection is presented in a padded and completely upholstered version with a wide range of bases and finishes.

The collection expands with new textile lines, featuring an exclusive, radical, elegant design, that leads to the universe of graphic arts. A new version offering a refined upholstery work, to be naturally located in every soft business and residential space.



Basamenti / bases:  
VN 4 gambe rovere marrone  
VN 4-legged brown oak base,  
Base a stelo verniciato opaco grigio grafite  
Matt painted graphite grey central leg

Basamenti / bases:  
Base a stelo verniciato opaco bianco  
Matt painted white central leg,  
4 gambe VN acciaio verniciato opaco bianco  
Matt painted white VN 4-legged steel base



## New fabrics with graphical details



1. Balla fabric

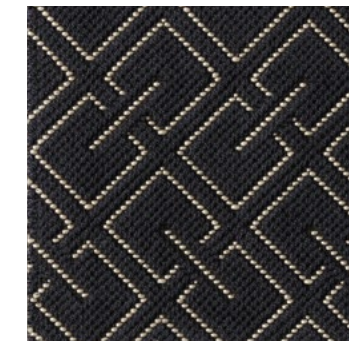

2. Grid fabric



3. Monometry fabric

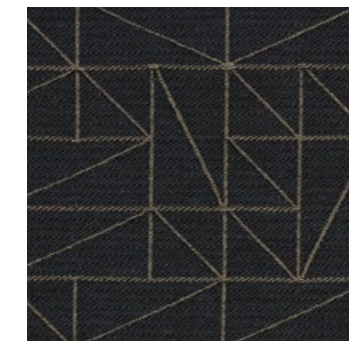

4. Timpi fabric

## Versions and finishes

Chair		Slim	
Central leg 	VN4 legged steel VN4-legged oak 	4 legged oak 	4 legged cross 4 legged oak cross 
Chair L53 D54 H80.5	L56 D56 H80.5	L54 D54 H80.5	L55 D54 H80.5
Slim L55 D53.1 H76.4	L56 D56 H76.4	L55 D54 H76.4	L53 D54 H76.4
Base			

Scocca composta da controscozza termoformata ed imbottita  
Shell composed of a thermoformed and padded countershell



# Flow Leather

Designed by Jean Marie Massaud



Il design raffinato, semplice e identitario di Flow Chair e Flow Slim varca i confini della sua democratica trasversalità, vestendo, letteralmente una nuova pelle e trasformandosi in un prodotto elegante e sartoriale, nasce così Flow Leather. La seduta di Jean Marie Massaud si propone rivestita in due tipologie di pelle.

La prima viene offerta in sette differenti tonalità, punzonata esternamente, mentre all'interno è liscia. Si tratta di una pelle premium, adatta a specifici ambienti domestici, come sale da pranzo, aree living, ma anche per gli spazi riservati all'home office e allo smart working.

La seconda tipologia invece, pensata per ambienti contract, come ristoranti, hotel, uffici, è una pelle punzonata internamente, mentre è liscia all'esterno: si tratta di un rivestimento contemporaneo, dinamico, di grande impatto, che a tratti ricorda il look dei sedili delle auto sportive e viene proposto in ben 11 tonalità.

Flow Chair and Flow Slim's smart, simple and eye-catching design, crosses the boundaries of its democratic cross-cutting nature, changing skin and turning into an elegant and tailor-made product. This is how Flow Leather was born. Jean Marie Massaud's chair comes coated in two types of leather.

The former is offered in seven different colours. It is micro-perforated externally, while inside it is smooth. It is a premium leather, suitable for specific home environments such as dining rooms, living areas, but also for home office and smart working spaces.

The second leather type, conceived for business and public venues such as restaurants, hotels, offices, is a leather micro-perforated internally, while it is smooth on the outside: it is a contemporary, dynamic, high-impact covering, which at times recalls the look of sports car seats and comes in 11 colour tones.



Basamenti / bases:  
4-legged cross verniciato opaco grigio grafite  
matt painted lead grey 4-legged cross

Flow Leather

2019 News book

Basamenti / bases:  
4 gambe rovere sbiancato / 4-legged bleached oak base  
VN 4 gambe rovere marrone / VN 4-legged brown oak base

65

64



## New leather



1. dettaglio pelle punzonata / detail of micro-perforated leather.

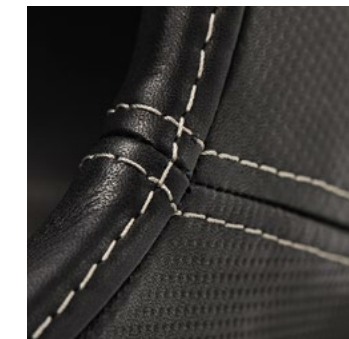

2. dettaglio cucitura Anilina con punto a contrasto / detail of the contrast stitching Anilina.

## Versions and finishes

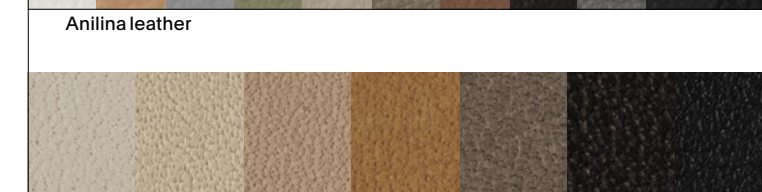
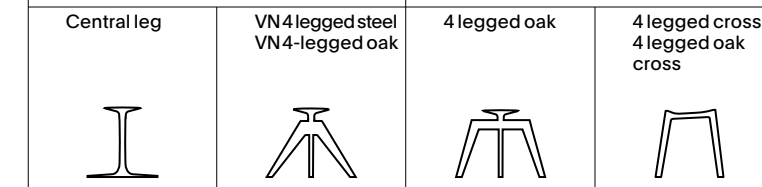
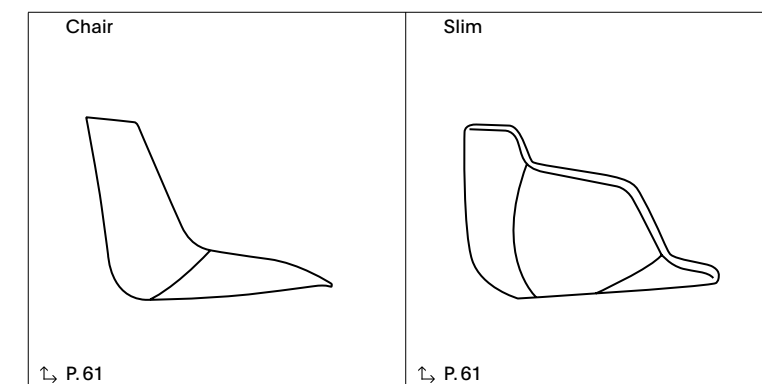

Ogni poltroncina è altamente personalizzabile grazie a due tipologie differenti di pellami  
Every armchair can be customised thanks to two different types of leather.

# Flow Filo

Designed by Jean Marie Massaud



Flow: un'icona senza tempo, che compie 10 anni!

Per festeggiare questa importante ricorrenza, Jean Marie Massaud ha creato un'inedita versione della celebre seduta, sia in versione chair, che slim, in cui si fondono ricerca ed artigianalità. Con un'anima d'acciaio, la nuova seduta viene proposta con o senza pad (indoor/outdoor). Un unico basamento a slitta completa il prodotto.

Perfetto abbinamento tra design ed estro manuale, Flow Filo spicca per la preziosa artigianalità della sua lavorazione, ottenuta saldando insieme i sottili e splendidi fili d'acciaio di cui è composta. Come un prezioso manufatto, la seduta trova la sua ideale collocazione in abitazioni dallo stile sia classico che contemporaneo, anche nella versione outdoor.

Flow: a timeless icon, that celebrates 10 years!

For this important anniversary, Jean Marie Massaud created a brand new version of the famous chair in its two versions – chair and slim – in which research and craftsmanship are combined. With a steel core, the new chair is proposed with or without pad (indoor/outdoor). A single sled base completes the product.

Perfect combination of design and manual flair, Flow Filo stands out for the precious craftsmanship of its processing, got by welding together the thin and shining steel wires which it is composed of. Like a precious artifact, the chair finds its ideal location in homes with both classic and contemporary style, also available in the outdoor version.

Slim  
Verniciata opaca bronzo e nichel nero  
Matt painted bronze and black nickel  
L56.8 D55.6 H76.5 seduta / seat H44



Chair  
Struttura cromo nichel, pad cuoio nero  
Nickel chrome structure, pad in black leather  
L53.2 D55.6 H80.5 seduta H44



Slim  
Verniciata opaca nichel nero  
Matt painted black nickel  
L56.8 D55.6 H76.5 seduta H44



Indoor and outdoor





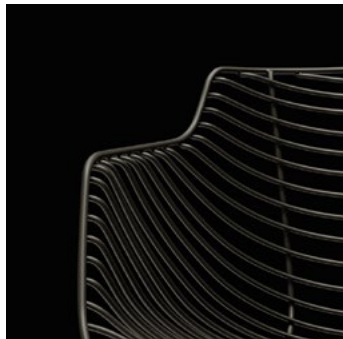

1. Verniciato opaco nichel nero / matt painted black nickel.



2. Verniciato opaco bronzo / matt painted bronze.

Versions and finishes

<p>Chair L53.2 D55.6 H80.5 seat H44</p> 	<p>Slim L56.8 D55.6 H76.5 seat H44</p> 
<p>Indoor pad in leather seat L45 D45</p> 	<p>Indoor pad in leather backrest L23 H39 / seat L45 D45</p> 
<p>Indoor/outdoor pad in polyurethane seat L45 D45</p> 	
<p>Steel rods</p>	<p>Pad</p>



# Aïku stool

Designed by Jean Marie Massaud



La famiglia di sedute Aïku, ispirata ai brevi e romantici componimenti poetici giapponesi (haiku), si amplia, proponendo anche la versione stool.

Lo sgabello Aïku, elegante, conviviale e cool, viene proposto con basamento in legno o con slitta. Quest'ultima versione è impilabile, il che rende lo stool straordinariamente performante, confermando la sua doppia natura, estetica e funzionale. La scocca viene proposta in tutte le opzioni disponibili per la seduta, inclusa la confortevole e avvolgente versione imbottita. Come la sedia, anche Aïku Stool è stato pensato per abitazioni, ristoranti – in particolare accanto a banconi di cucine, bar o aree conviviali – spazi collettivi.

Negli uffici è una soluzione ideale per le sempre più diffuse e veloci riunioni "in piedi" delle imprese 4.0, in spazi condivisi e un po' meno formali delle sale riunioni.

The Aïku chair collection, inspired to the short and romantic Japanese poems (haiku), extends and also includes stools.

Aïku stool – elegant, convivial and smart – comes either with wooden base or with sled. The latter is stackable, which makes the stool highly performing, thus confirming its double aesthetic and functional nature. The shell is offered in all of the versions available for the chair, including the comfortable and wrapping padded model. Like the chair, Aïku stool was conceived for homes, restaurants – in particular, is recommended next to kitchen counters, bars and get-together areas – and collective spaces.

In offices, Aïku stool is an ideal solution for the increasingly widespread habit of fast and standing meetings in 4.0 companies, in shared spaces, slightly less formal than meeting rooms.



Scocca in polipropilene bicolore nero/grigio scuro  
base a slitta verniciata opaca grigio grafite  
Shell made from two-colour polypropylene black/dark grey  
matt painted graphite grey sled base







Aïku stool

Great impact and comfort



1. Slitta in filo di acciaio, verniciato opaco nei colori bianco, grigio grafite o cromato / Sled base in steel wire, matt painted white, graphite grey or chrome-plated.

### Versions and finishes

<p>Sled base L61 D55 H96 seat H64</p> 	<p>Sled base L63 D55 H109 seat H76</p> 
<p>4-legged oak base L49 D55 H96 seat H64</p> 	<p>4-legged oak base L49 D55 H109 seat H76</p> 
<p>Shell</p>  <p>Base</p> 	





# M1 color

Designed by Piergiorgio Cazzaniga

Le linee pure ed essenziali di MDF Italia declinate in un'eleganza pratica, multifunzione, più informale.

E' questo il biglietto da visita di M1 di Piergiorgio Cazzaniga, una seduta green, completamente riciclabile. Ma anche impilabile nella versione con scocca in plastica, all'insegna della massima funzionalità in ogni spazio. Disponibile con scocca in plastica, verniciata o rivestita con più di 400 varianti colore tra tessuti e pelli, M1 si propone con il classico basamento in acciaio inox o cromato, al quale si è recentemente aggiunto il basamento verniciato ton-sur-ton.

Un colore, un'emozione, per assecondare le esigenze di ambienti differenti: dai contesti domestici quali la cucina, il living e la camera da letto, agli ambienti contract, come uffici, sale conferenze sino ai luoghi pubblici, come bar e ristoranti. La silhouette di M1 si ritrova sia in ambienti chiusi che esterni, confermando la sua versatilità che l'ha resa protagonista di molti progetti.

MDF Italia pure and essential lines expressed in a practical, multitask slightly informal elegance.

Piergiorgio Cazzaniga's M1 looks like this: an eco-friendly, fully recyclable chair, that is also stackable, in the plastic shell version, offering top functionality in every space. Available with plastic shell, either painted or coated with over 400 fabric or leather colour variations, M1 comes with the classic stainless steel or chrome base, and more recently, with a tone-on-tone painted base.

A colour, an emotion to meet the needs of different environments: from home – kitchen, living area and bedroom – to business spaces, such as offices, conference rooms, up to public venues, such as bars and restaurants. M1 shape can be seen in both indoor and outdoor spaces, thus confirming its versatility that has made it the protagonist in many projects.



New colors



1. Le scocche possono essere abbinare allo stesso colore dei basamenti, oppure abbinare alle finiture cromate o inox / the shells can be matched with bases in the same colour or with the chrome-plated or stainless steel finishes.

Dimensions and finishes

L54 D49.7 H75.7  
seat H44

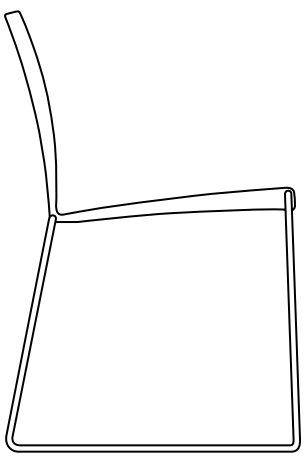

Shell and base



# Rock Table

Designed by Jean Marie Massaud



Rock Table nel 2019 si arricchisce di nuove finiture: piano in legno texturizzato rovere sbiancato, in abbinamento alla base in cemento naturale e piano in legno texturizzato rovere antracite, in abbinamento alla base in cemento antracite. Top in legno di quercia naturale (rovere), con particolare trattamento superficiale ottenuto grazie ad innovativi processi di levigatura, donano una caratteristica ed originale finitura "tessile", unica nel riprodurre l'intreccio di trama ed ordito abbinata alla naturale matericità del legno.

A completare la particolare superficie la raffinata finitura sbiancata ed antracite, la combinazione della texture con le cromie del legno creano un originale effetto opaco e disteso ma allo stesso tempo rugoso e vissuto. L'iconico tavolo, dalla silhouette fluida ed elegante, rivela completamente la natura di quello che rappresenta: "una tavola rotonda" che levita apparentemente sopra una solida base inorganica. Una miscela di materiali naturali e industriali, che si fondono in un prodotto unico dal design morbido nella stessa filosofia della collezione Flow.

Un oggetto raffinato e solido, leggero e stabile, radicale e sensuale. Lo stile unico, basato sulla semplificazione delle forme, si combina con sistemi di produzione innovativi e questo rende i tavoli Rock adatti non solo ad aree living e soggiorni moderni ma anche a contesti lavorativi, come uffici, meeting room, conference rooms dalla forte identità.

In 2019 Rock Table introduces new finishes: a textured whitened oakwood top, combined with the natural cement base and a textured anthracite oakwood top, combined with the anthracite concrete base. Top in natural oak wood with a special surface treatment obtained thanks to innovative smoothing processes that create a characteristic and original "textile" finish, unique in the way it reproduces the warp and weft pattern combined with the natural material feel of the wood.

The original surface is completed with the refined bleached and anthracite finish. The combination of the texture and the colours of the wood creates an original relaxed matt effect that also has a furrowed and slightly worn feel to it. The iconic table, with its fluid and elegant silhouette, completely reveals the nature of what it represents: "a round table" that seems to float above a solid, inorganic base. A mixture of natural and industrial materials that are blended to create a new product with a smooth design, following the same philosophy of Flow collection.

A refined solid object, light and stable, radical as well as sensual. Rock Table unique style, based on simplified shapes, is combined with innovative production systems and this makes MDF Italia tables suitable not only to modern living rooms, but also to lounge designs and working contexts, such as offices, meeting rooms, conference rooms with a strong identity.

Top in legno texturizzato antracite  
base in cemento antracite  
Top in anthracite textured wood  
anthracite cement base



## New textured oak



1. Legno di rovere sbiancato texturizzato, spessore 25 mm / textured bleached oak, 25 mm thick.

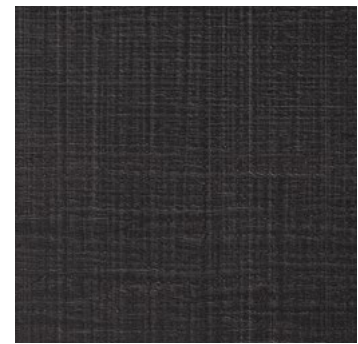

2. Legno di rovere antracite texturizzato, spessore 25 mm / textured anthracite oak, 25 mm.

## Dimensions and finishes

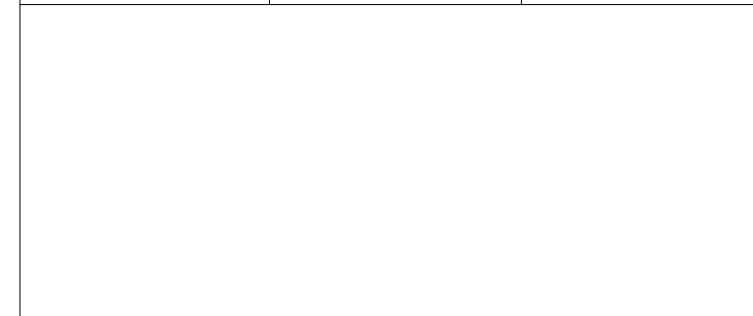
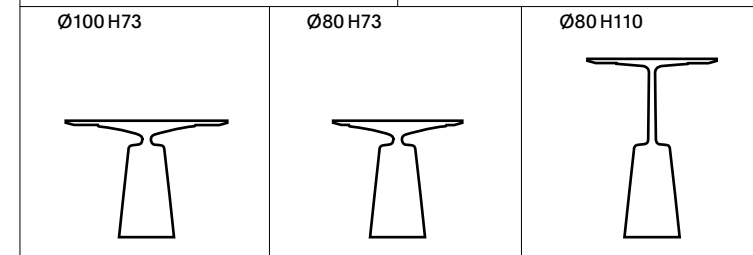
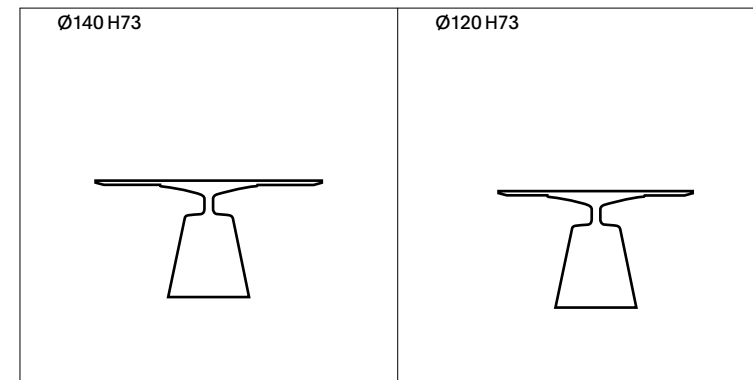

Top



Top legno texturizzato rovere sbiancato  
base cemento naturale / top in bleached oak  
textured wood, natural cement base  
Ø140 H73



# Tense

## Diamond

### Fine Wood

### Low table

### Outdoor

Designed by Piergiorgio Cazzaniga

“Progettare semplificando, per estrapolare l’essenza”.  
È stata questa l’idea che ha ispirato Piergiorgio e Michele Cazzaniga, dalla quale nel 2009 è nato Tense, un tavolo speciale, semplice, essenziale e solo apparentemente esile.

Il suo top infatti, racchiude un cuore tecnologico, il quale gli consente di raggiungere grandi dimensioni. Il tavolo, icona della collezione MDF Italia, celebra quest’anno il primo decennio. Oggi Tense viene proposto in 5 altezze, strutturandosi come sistema articolato in varie tipologie, per soddisfare in modo completo ed esauriente le esigenze dei mercati internazionali: coffee table e bench, dining table e working table, consolle e high table. Dal 2016 la collezione Tense include anche Tense Material: proposto in diversi materiali – legni, pietre, marmi, metalli – questa variante trasmette emozioni profonde, ma sempre differenti a ogni osservatore, poiché associate a una sapiente accentuazione delle peculiarità dei materiali usati.

Di grande impatto anche l’ultima versione di Tense – Curve – morbida e conviviale, mentre Tense Outdoor grazie alla ricerca sui materiali utilizzati, garantisce la massima performance anche all’esterno.

Il sistema di tavoli Tense, archetipo di sobrietà, multifunzionalità e sottrazione, s’integra in numerosi spazi della vita quotidiana, sia residenziali che contract, affermando con decisione la propria natura trasversale e cosmopolita.

“Designing by simplifying, to extrapolate the essence”.  
This was the idea that inspired Piergiorgio and Michele Cazzaniga, giving birth to Tense in 2009, a special, simple, and only apparently thin table.

Its top, in fact, contains a technological heart, which allows it to reach large dimensions. Today Tense comes in 5 heights, offering itself as a system divided into various models, to meet the needs of international markets in a complete and exhaustive way: coffee table and bench, dining table and working table, console and high table. Since 2016, Tense collection has also included Tense Material: offered in different materials – woods, stones, marbles, metals – this variant expresses deep emotions, that are everchanging according to the observers, since they are associated to an excellent accentuation of the peculiarities of the materials used.

Considerably eye-catching is also the latest version of Tense: Curve, highly soft and convivial, while Tense Outdoor, thanks to a deep research on materials, ensures top performances outdoor, as well.

Tense table system, archetype of sobriety, multifunctionality and subtraction, integrates in plenty of spaces in daily life, both residential and contract, firmly asserting its cross-cutting and cosmopolitan nature.

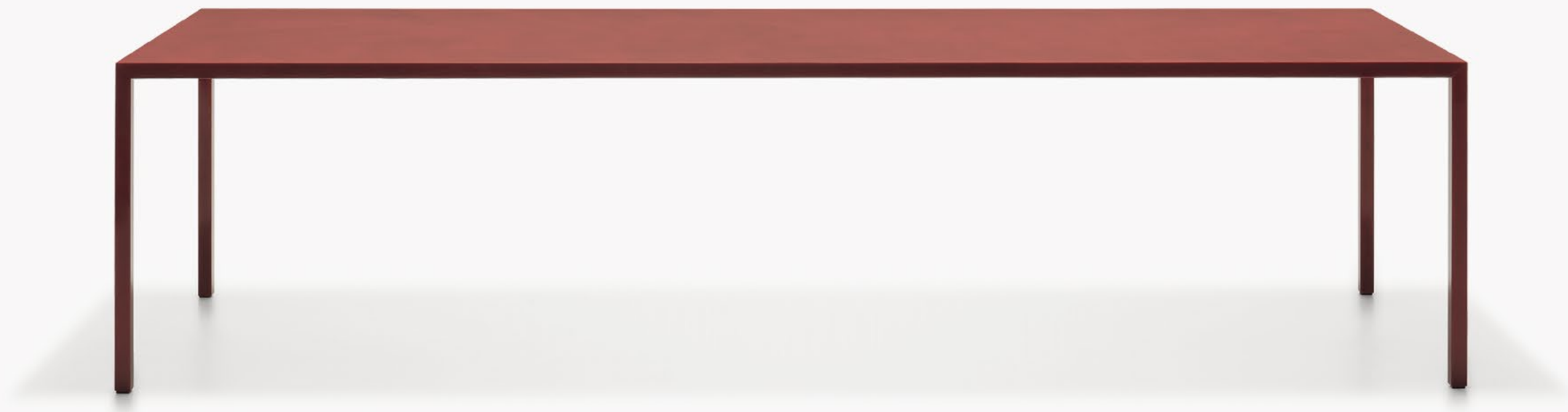









Tense outdoor  
in goffered painted  
aluminium

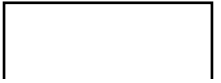

1. Tavolo dalla finitura monomaterica, completamente rivestito in lamiera di alluminio / A table with a mono-material finish, entirely covered in aluminium sheet.

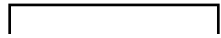
### Dimensions and finishes

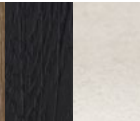
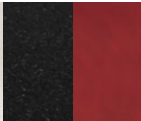
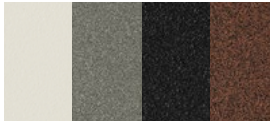
<p>H110 High table bar and office D80 L140, 160, 180, 200 D90 L160, 180, 200, 220 D100 L200, 220 D150 L200 Square: L80, 90, 100, 120, 150</p> 	<p>H90 Consolle, High and working table D45 L140, 160, 180, 220 D80 L140, 160, 180, 200 D90 L160, 180, 200, 220, 240 D100 L200, 220, 240, 260, 280, 300 D120 L240, 260, 280, 300 D150 L200, 240, 300 Square: L80, 90, 100, 120, 150</p> 		
<p>H73 Dining and working table D80 L140, 160, 180, 200 D90 L160, 180, 200, 220, 240 D100 L200, 220, 240, 260, 280, 300 D120 L240, 260, 280, 300, 360, 400 D150 L200, 240, 300, 360, 400 Square: L80, 90, 100, 120, 150</p> 	<p>H45 Coffee table, Bench D45 L140, 160, 180, 220 D80 L140, 160, 180, 200 Square: L80, 90, 100, 120, 150</p> 		
<p>H35 Low table D45 L140, 160, 180 D80 L140, 160, 180, 200 Square: L80, 90, 100, 120, 150</p> 	<p>H73 Outdoor* D90 L180 D100 L240 D120 L280 Square: D140 L140</p> 		
Wood	Marble	Diamond	Outdoor*
			



# Tense Curve

Designed by Piergiorgio Cazzaniga



Tense, l'elegante e versatile tavolo di MDF Italia, arricchisce la sua già ampia collezione con una nuova proposta: Tense Curve, dalla silhouette morbida e sinuosa.

La nuova versione nasce dalla volontà dei progettisti Piergiorgio e Michele Cazzaniga d'intraprendere nuove ricerche formali, che hanno consentito di approdare alla forma tonda, la quale permette di aumentare la convivialità degli ospiti, che possono interagire quando sono seduti, senza avere limitazioni alla vista.

Tense Curve trova la sua collocazione ideale sia nelle sale da pranzo e nei living di casa, sia in contesti lavorativi, dove i tavoli ovali vengono molto apprezzati nelle sale riunioni.

Tense, MDF Italia's elegant and versatile table, extends its already wide collection with a brand new proposal: Tense Curve, featuring a soft and sinuous silhouette.

The new version originates from designers Piergiorgio and Michele Cazzaniga's will to undertake new formal researches, that enabled them to approach the round shape, that allows to increase the conviviality of guests, who can interact when they are sitting, with no sight restrictions.

Tense Curve can be ideally placed in both dining rooms and living areas, and in working contexts, where oval-shaped tables are increasingly appreciated in meeting rooms.



Elegant and versatile



1. Piano, bordi e gambe rivestiti da massello di rovere / top, edges and legs coated by natural oak.

Dimensions and finishes

H73

W150 D 150

W200 D 90; W260 D 100; W300 D 120  
W360 D 140; W400 D 150

Resin Marble      Diamond Wood



# S Table

Designed by Xavier Lust

Nel 2007 l'inusuale ed accattivante estetica di S Table, del designer Xavier Lust, con il suo originale basamento, che evoca una scultura d'arte contemporanea, ha anticipato di oltre dieci anni l'attuale concetto di tavolo: un elemento d'arredo dal forte impatto estetico frutto di creatività, ricerca e sperimentazione e dell'utilizzo di pregiati materiali come essenze preziose, pietre, inserti in metallo.

In occasione della 58esima edizione del Salone del Mobile, S Table viene riproposto nella nuova finitura marmo ricostruito, realizzata partendo dalla polvere di marmo che, sapientemente miscelata ad un legante, viene stesa manualmente su tutta la superficie del tavolo.

Questa nuova veste contribuisce a rendere l'oggetto ancora più raffinato ed esclusivo, portavoce nel mondo della creatività e del "saper fare italiano".

In 2007, the unusual and eye-catching S Table, designed by Xavier Lust, with its original base that evokes a contemporary art sculpture, anticipated the current table concept by more than 10 years: a furnishing solution with a strong aesthetic impact, resulting from creativity, research and experimentation and the use of valuable materials such as precious essences, stones, metal inserts.

On the 58th Salone del Mobile, S Table comes in the new finish in reconstructed marble, developed starting from marble powder that, expertly mixed with a binder, it is spread manually over the whole table top.

The new look contributes to making the object even more refined and exclusive, a symbol in the world of creativity and Italian know-how.



New finishes  
in reconstructed marble

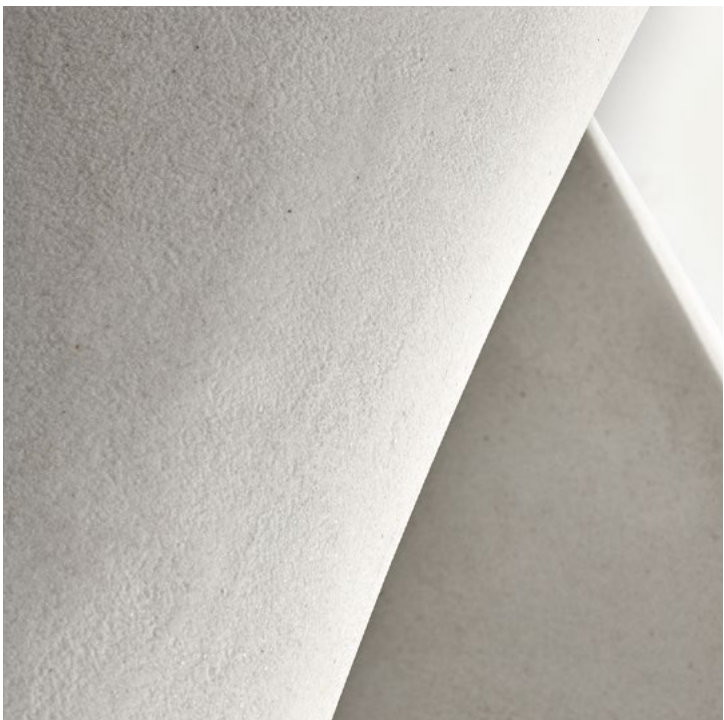

1. Questa particolare finitura è realizzata in marmo ricostruito partendo dalla polvere di marmo che, sapientemente miscelata ad un legante, viene stesa manualmente su tutta la superficie della base / This particular finish is made of reconstructed marble starting from the marble powder that, appropriately mixed with a binding resin, is spread manually over the entire surface of the stand.

Dimensions  
and finishes

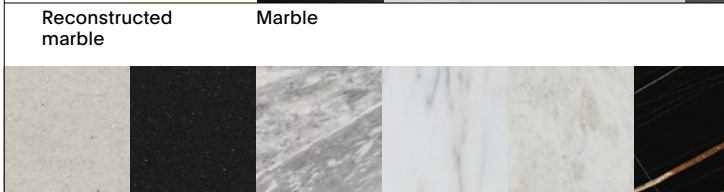
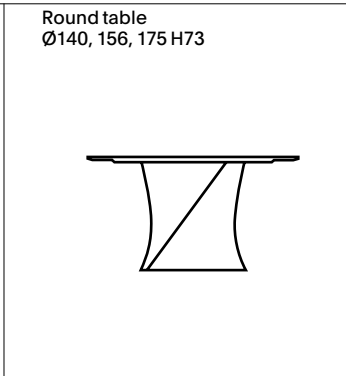
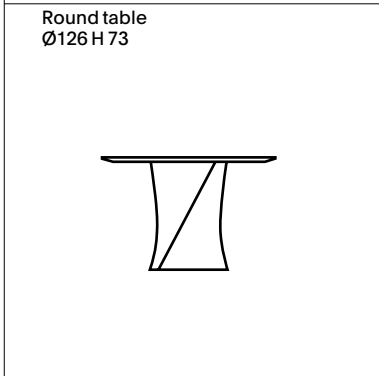
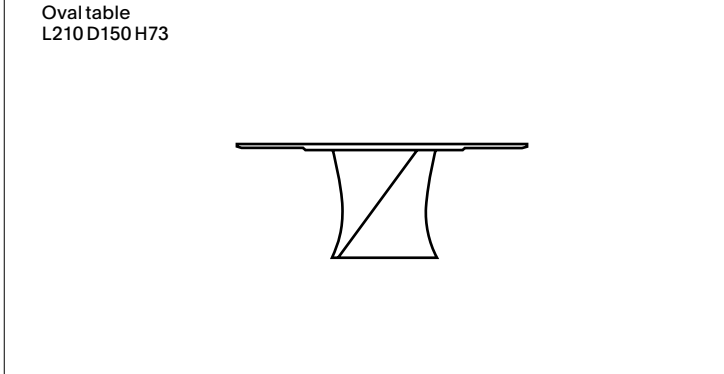



# Metodo

Designed by Leonardo Talarico

Un design puro e rigoroso, dalle linee nette e precise, ma estremamente originali: cattura immediatamente l'attenzione l'inedito tavolino Metodo.

Progettato seguendo uno schema stilistico rigoroso, Metodo sviluppa la sua forma nello spazio con cerchi che, posti su piani differenti, s'incontrano per creare sia il piano d'appoggio che l'intera struttura. Il risultato è un prodotto semplice, ma dal tratto identitario, essenziale, ma dalla forte personalità.

Metodo s'inserisce perfettamente in svariati ambienti residenziali: dal living, accanto ai divani sino alla zona notte, come comodino ultra contemporaneo.

A pure and rigorous design, featuring clear and precise, yet highly original lines: the brand new Metodo coffee table immediately catches the eye.

Conceived according to a rigorous stylistic pattern, Metodo develops its shape in the space by means of circles that, placed on different levels, meet to create both the top and the entire structure. The result is a simple product, unforgettable and essential, with a strong personality.

Metodo perfectly fits into many residential spaces: from the living area next to the sofas, up to the night area, as an ultra-contemporary bedside table. With its silhouette, that from the first look is unmistakable, Metodo is an emotion, well defined in a living space.

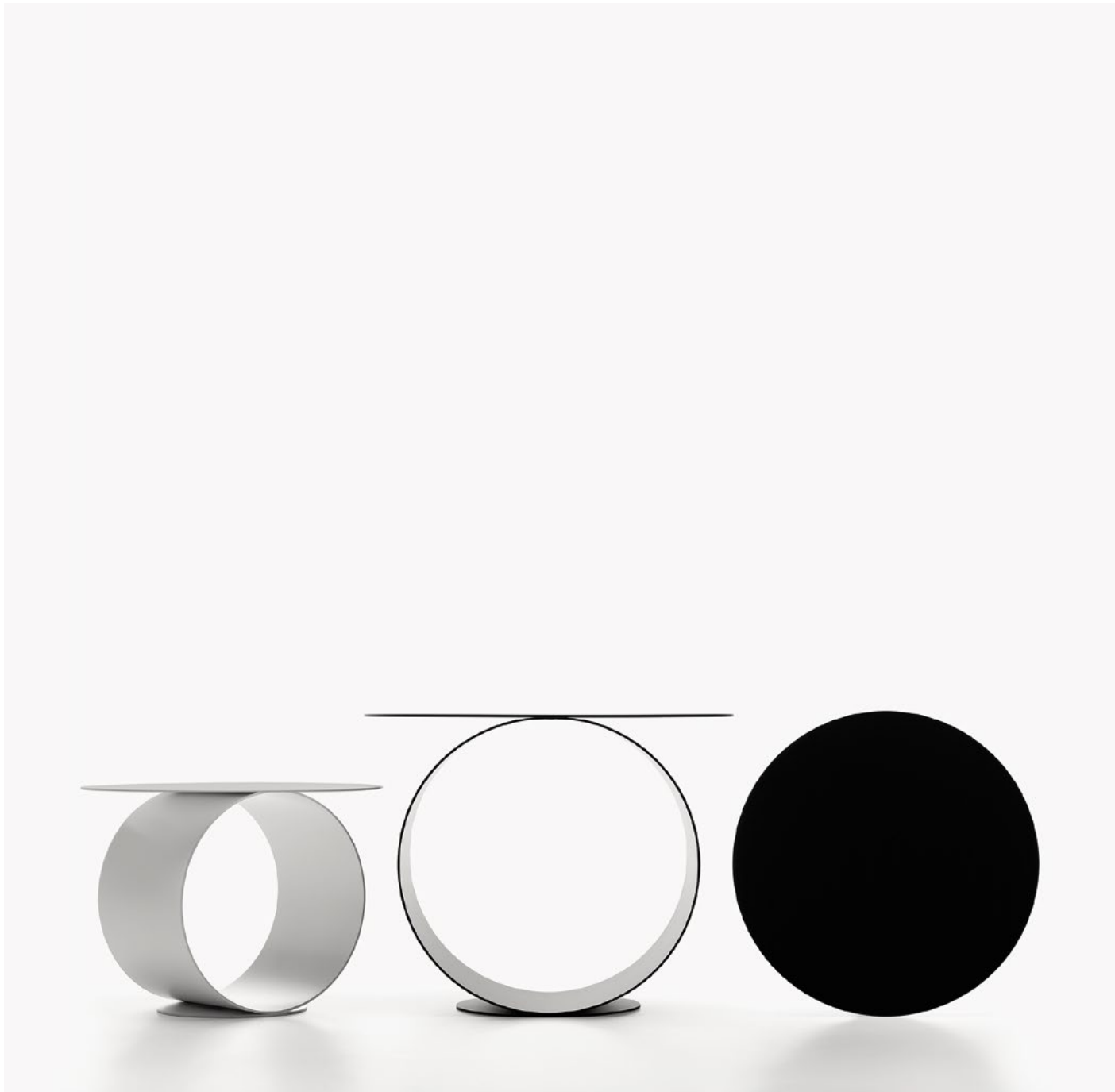

New coffee table



2. Struttura in acciaio spessore 3 mm / 3 mm thick steel structure in powder coated.

Versions and finishes

Ø50 H40

Ø40 H30

Structure and top

Un pensiero progettuale essenziale dalla forte identità, che ha come obiettivo lo studio delle forme più semplici. An essential design concept with a strong identity, aiming to study the simplest shapes.

# 20.Venti Home

Designed by 967ARCH



Linee semplici e pure, eleganza formale, dimensioni ridotte, superficie di scrittura generosa sono le peculiarità di 20.Venti Home, la nuova scrivania dall'immagine contemporanea ma con una anima retrò.

MDF Italia affida allo studio 967ARCH il compito di ripensare, in chiave contemporanea, lo scrittoio. Dalle riflessioni su questo complemento d'arredo e sulla sua funzione nell'era di internet nasce 20.Venti Home, una funzionale scrivania di lavoro per gli ambienti domestici, l'hotellerie, le biblioteche o i college più esclusivi.

Una proposta dal design elegante ed innovativo, che si caratterizza per un'inedita ed un'inusuale tasca in morbido panno in cui riporre documenti, libri, giornali o il tablet, un dettaglio che definisce la vocazione domestica dell'oggetto, senza rinunciare all'ergonomia ed alla funzionalità. Il piacere visivo di un arredo iconico per diversi utilizzi: per lavorare, per scrivere, per "navigare", o come discreto secretaire, grazie al vano portaoggetti che si cela con molta discrezione sotto il piano di lavoro a ribalta.

Simple and pure lines, formal elegance, reduced size, generous writing surface are key features of 20.Venti Home, the brand new desk, featuring a contemporary look but with a retro soul.

MDF Italia relies on 967ARCH to reinterpret the writing desk. 20.Venti Home originates from the reflections on this furnishing accessory and its function in the internet age, a functional work desk for homes, hotellerie, libraries or for the most exclusive colleges.

A smart and innovative design solution, standing out for an unusual soft cloth pocket for storing documents, books, newspapers or a tablet, a detail that defines the object's home vocation, without abandoning ergonomics and functionality. The visual pleasure of an iconic piece of furniture for different end uses: to work, to write, to surf on the web or even as a sober secretaire, thanks to the storage compartment that is hidden very discreetly under the tilting worktop.







New home working desk



1. La parte anteriore dello scrittoio è caratterizzata da una sacca in panno, Divina Melange / The front of the desk is notable for its Divina Melange cloth bag.

Dimensions and finishes

L120 D60 H75 / 81.5

Structure                      Top

Cassettino portaoggetti interno accessibile mediante apertura a ribalta di un settore del piano  
Desk that can be accessed through a flap door.

# 20.Venti system

Designed by 967ARCH



20.Venti, il sistema per l'ufficio progettato da 967Arch si caratterizza per un design lineare e iconico, proprio del DNA della collezione MDF Italia.

Tramite la riflessione sullo scrittoio, l'archetipo della postazione di lavoro, si propone di ricreare in chiave contemporanea una nuova atmosfera dell'office. La contrapposizione tra pieni e vuoti, l'accostamento attento di diverse finiture e l'integrazione del cablaggio nella struttura portante definisce una rinnovata proposta di arredo ufficio.

La sfida tecnica parte dall'utilizzo di una struttura esile, un profilo 20x20 che genera il frame del telaio, un segno che si integra alla perfezione con le altre collezioni di tavoli e contenimento di MDF Italia.

Disegnato da 967Arch per MDF Italia può offrire un'ampia varietà di misure e finiture utilizzabili per aree operative, uffici direzionali e per contesti residenziali, dove è sempre più diffuso l'uso di tavoli per il lavoro nomade e tecnologico.

In aggiunta alle varianti desk singolo e workstation 2 posti, sono state integrate nella collezione la nuova workstation 4 posti e la workstation flex, per postazioni condivise con dimensioni personalizzabili secondo le esigenze. Inoltre, è stato integrato anche la nuova High workstation altezza 110 cm, soluzione ideale per riunioni veloci e "standing meetings", in spazi condivisi e un po' meno formali delle sale riunioni.

This office system 20.Venti features a linear iconic design typical of MDF Italia's "dna". A reflection on the desk, the archetypal workstation, proposes to create an office atmosphere in a contemporary key.

The contrast between full and empty volumes, the carefully studied combination of various finishes and the cables built into the bearing frame define an renewed proposal for office furnishings.

The technical challenge starts from the use of a slender frame generated by a 20x20 profile, a feature that perfectly merges with MDF Italia's other table and storage collections.

Designed by 967Arch for MDF Italia to offer an extensive choice of dimensions and finishes for working areas, management offices and residential settings where tables for nomadic technological work are becoming a common trait. Further to the single desk and workstation two users, a new workstation four users and a flex workstation for shared working space – with customizable dimensions according to the needs – have been integrated into the collection.

In addition, the new 110 cm high workstation has also been integrated: an ideal solution for quick and standing meetings, to be held in shared and less formal spaces than meeting rooms.



New workstation



2. La variante HIGH workstation è dotata di canalina strutturale accessibile mediante antina passacavi centrale / the HIGH workstation has a structural wireway that can be accessed via a central cable management opening.

Versions and finishes

Workstation 2/4 users  
 L160 D160 H75  
 L180 D160 H75  
 L320 D160 H75  
 L360 D160 H75

Single desk  
 L160 D90 H75  
 L180 D90 H75  
 L200 D90 H75

High workstation  
 L160 D100 H110  
 L180 D100 H110  
 L200 D100 H110

Top Structure



Open cabinet



20.Venti High Workstation  
 top in fenix nero opaco, struttura verniciato opaco  
 grigio grafite / top in matt black fenix  
 matt painted graphite grey structure  
 L200D100H110



# Neil Basic

Designed by Jean Marie Massaud

Neil si presenta in due nuove versioni: Neil Basic e Neil Basic con meccanismo di ritorno. Due basi uniche che ridefiniscono il concetto di classica poltrona.

Neil è una lounge chair che celebra leggerezza e competenza. Un linguaggio radicale, un comfort avvolgente ed un elegante tecnicismo, che si sposano con sorpresa a finiture raffinate e naturali. Proposta nella sua versione a quattro razze, questa nuova collezione lascia spazio a future tipologie e a diverse situazioni e usi.

Disponibile nella variante alta e bassa, con o senza bracciolo, versione totalmente rivestita o con controscocca. Questa nuova versione, dal raffinato lavoro di tappezzeria, troverà la sua naturale collocazione in tutti gli spazi soft contract o residenziali. La poltrona Neil si presenta, oggi, come una nuova icona di essenzialità.

Neil is presented in two new versions: Basic and Basic with return mechanism. Two unique bases that redefine the classic armchair concept.

Neil is a lounge chair celebrating lightness and competence. A radical language, a cosy comfort and an elegant technique that match surprisingly well with refined, natural finishes. Now introduced in a four-star version, this new collection leaves space for further future options and different situations and uses.

Available in high-back and low-back version, with or without armrests, padded version or version with counter-shell. A new version offering a refined upholstery work, to be naturally located in every soft business and residential space. The Neil armchair emerges today as a new icon of essential style.



# New Basic version



- 1. Poltrona con fusto centrale e base a 4 razze, basculante, girevole a 360° con meccanismo di ritorno. Armchair with 4-points star steel base with central frame and tilting mechanism. 360° swivel with return mechanism.
- 2. Poltrona con fusto centrale e base a 4 razze, meccanismo girevole a 360° / armchair with 4-points star steel base and central frame. 360° swivel.

# Versions and finishes

L78 D67 H69.5 seat H41	L86 D67 H69.5 seat H41
L78 D67 H95.5 seat H41	L86 D67 H95.5 seat H41
L78 D67 H69.5 seat H41	L86 D67 H69.5 seat H41
L78 D67 H95.5 seat H41	L86 D67 H95.5 seat H41

Structure

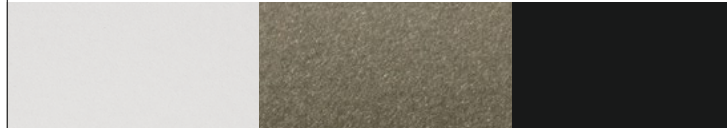

Versione bassa con o senza braccioli  
Low-back version with or without armrest  
Tessuto / fabric Londra 07  
L78 D67 H69.5 seduta / seat H41



# Neil Twist

Designed by Jean Marie Massaud

Grintosa, versatile, vibrante, ma al contempo icona di essenzialità, in perfetta armonia con lo stile di MDF Italia. Queste le caratteristiche di Neil, che viene proposta in un'inedita versione: Neil Twist, il cui eloquente nome lascia intuire che la corda intrecciata manualmente è la protagonista della seduta, con in più, un dettaglio – il punto a incrocio interno a contrasto – che aggiunge carattere al colpo d'occhio.

In questa nuova versione, la seduta di Jean Marie Massaud si distingue per la sua straordinaria versatilità: può infatti essere utilizzata con disinvoltura sia all'interno che in outdoor, dove i suoi colori, neutri o decisamente brillanti, caratterizzeranno parchi e giardini privati, luoghi di aggregazione, hotel e spazi pubblici.

Gritty, versatile, vibrant, yet at the same time an icon of essentiality, in perfect harmony with MDF Italia's style. These are the main features of Neil armchair, that today comes in a brand new version: Neil twist, whose eloquent name makes us sense that the manually braided rope is the project's protagonist, with a key detail – the contrasting internal crossstitch – that adds character to the overall view.

In this new version, Jean Marie Massaud's chair is highly versatile: it can actually be used both indoors and outdoors, where its neutral or very bright colours will be outstanding in parks and private gardens, meeting places, hotels and public spaces.

Intreccio scocca arancione lucido  
Shell weaving glossy orange 11  
Struttura verniciata opaca bronzo  
matt painted bronze structure

Outdoor and indoor



1. Le sedute sono realizzate con intreccio originale ed esclusivo / The seats are made with an original and exclusive weave.



Versions and finishes

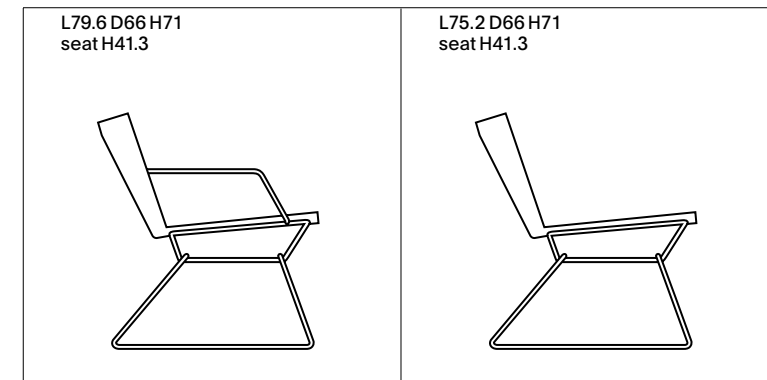

L79.6 D66 H71  
seat H41.3

L75.2 D66 H71  
seat H41.3

Shell weaving



Structure

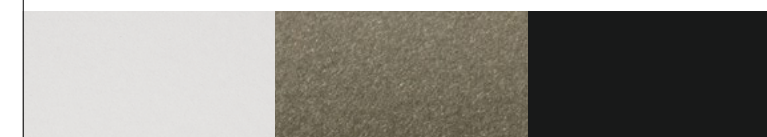

Intreccio scocca ecrù / Shell weaving ecrù 23  
Struttura verniciata opaca nichel nero  
Matt painted black nickel structure  
L75.2 D66 H71 seduta / seat H41.3

# Mirror Lines

Designed by Irene Goldberg & Pitsou Kedem



Un'ispirazione giunta dal paesaggio agricolo, che ha dapprima sorpreso, quindi guidato gli architetti Irene Goldberg & Pitsou Kedem a realizzare per MDF Italia la collezione di sei specchi Mirror Lines. Più precisamente sono stati i campi irrigati e le risaie visti dall'alto, che li hanno spinti a riprendere gli schemi geometrici di quel mondo e a proiettarli in una creativa linea di specchi.

E il colpo d'occhio è emozionante: nella struttura in metallo verniciato nichel nero oppure nichel perla opaco accanto alla luce riflessa dagli specchi, si distinguono inserti decorativi in differenti materiali: marmo Guatemala, marmo di Carrara bianco opaco, oppure in onice o ottone, quest'ultimi dall'effetto cangiante.

Una soluzione d'arredo che veicola vitalità ed energia, per una veduta d'insieme inusuale, originale e altamente coinvolgente.

An inspiration coming from the agricultural landscape, that at first surprised, then guided, the architects Irene Goldberg & Pitsou Kedem to develop Mirror Lines, the new MDF Italia collection of six mirrors.

More precisely, the irrigated fields and the rice paddies seen from above led the architects to resume the geometric patterns of that world, projecting them into a creative line of mirrors.

The glance is exciting: in the frame painted either black nickel or matt pearl nickel, next to the light reflected by the mirrors, decorative inserts in different materials stand out: Guatemala marble, matt white Carrara Marble, or in onyx or brass, the latter with an iridescent effect. A furnishing solutions that irradiates vitality and energy, for an unusual, but original and highly involving overall view.



# Creative mirror

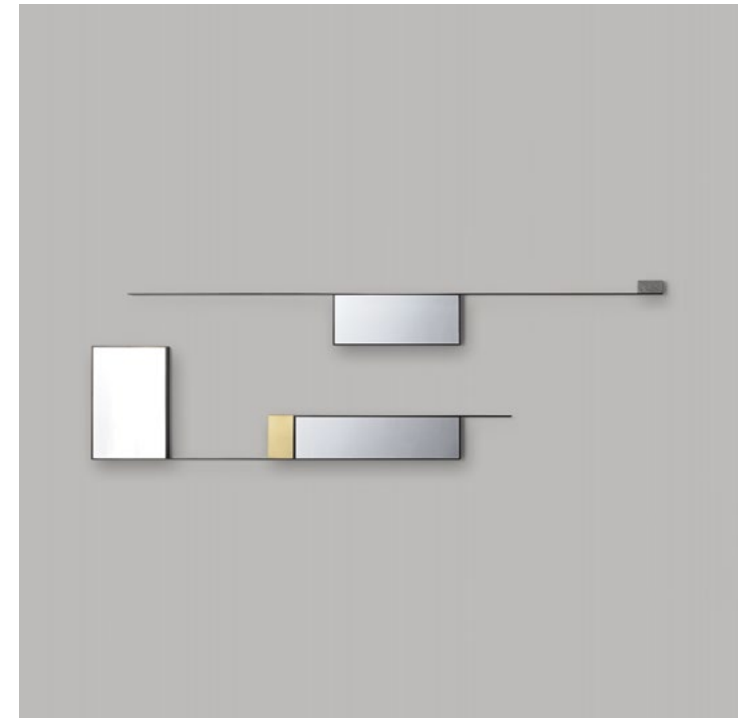

1. Composizione 1/2, struttura verniciato opaco nichel nero, matt painted black nickel structure / decorazioni in onice opaco verde/ottone, decorative element in green matt onyx/brass. L210 P5 H25 / L164 P5 H45

## Compositions and finishes

<p>Composition 1 L210 D5 H25</p>	<p>Composition 2 L164 D5 H45</p>
<p>Composition 3 L155 D5 H30</p>	<p>Composition 4 L155 D5 H45</p>
<p>Composition 5 L12 D5 H145</p>	<p>Composition 6 L32 D5 H140</p>

Decorative elements

Frame

Composizione / composition 3/4  
Struttura verniciato opaco nichel nero  
Matt painted black nickel structure  
Decorazioni in marmo carrara bianco opaco/onice verde  
Decorative element in white carrara marble/green onyx  
L155 D5 H30 / L155 D5 H45

Mirror Lines

2019 News book

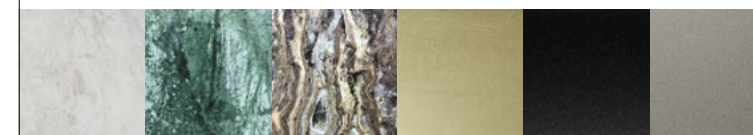

Design and concept

CCRZ

Text

Communication

& Marketing, MDF Italia

Ludovica Niero, CCRZ

Concept styling

Studio Monti

Photo

Lorenzo Cappellini Baio

Thanks to

Flos

Luceplan

Robi Renzi

Society Limonta

Made and Printed in Italy

Navapress Milano

2019 June

MDF Italia Srl Società Unipersonale

Headquarter

Via Fratelli Cervi 4/A

22066 Mariano Comense (CO)

Showroom Milano

via della Chiusa

© 2019

**MDF Italia all rights reserved**

MDF Italia reserves the right to change,  
at any time and without prior warning,  
the technical specifications of any products  
illustrated in this catalogue.

[www.mdfitalia.it](http://www.mdfitalia.it)

M920099-0577

Follow us



**mdf italia**

