

BESPOKE STORIES

BLACK TIE



The smallest details make the biggest difference: they are the ones which make the real difference. Black Tie has a history of devoting great attention to all details, to the careful study and selection of materials, and the refined/special design which distinguishes its brand.

It is above all, and thanks to the painstaking attention given to even the smallest of details, that Black Tie has become a successful brand with a promising future.

Pier Luigi Frighetto the founder of Black Tie, has dedicated over thirty-five years of experience and passion to the production of upholstery. Blessed with an inquisitive mind and tireless researcher, this eclectic entrepreneur transmits through Black Tie his idea of elegance, luxury and comfort. Carefully selected International showrooms are among the few exclusive partners selected for this project.

These partners, are strategically located, share a vision of absolute exclusivity. Fine taste is foremost, while never being ostentatious.

Velvets, printed textiles, walnut wood and woven leather. Metal finishing, for articles with golden or bronze colored accents. A sophisticated collection, designed for environments characterized by a sober but refined elegance.

Environments where the concept of luxury is above all connected to "Living Well".

The Veneto region, the birthplace and land of our founder, forms the perfect frame to the story of each and every piece of this collection.

Sofas, poufs and comfortable armchairs, tables and lamps.

Each product is naturally suited to its collocation in private contemporary Wunderkammer hidden in the Vicentine hills.

Protagonists together with the products, the rooms of one of the most wonderful projects of Palladio: the Venetian Villas, the perfect scenography for this collection. The air is filled with the magical atmosphere of homes rich in history, perfect stage settings where a gentle sumptuousness embraces who enters.

Timeless ambients, where the contemporary naturally marries the past while enhancing both while respecting their uniqueness.

Each and every object is chosen to tell something, each detail to create a greater image.

Always inspired by an ideal of timeless beauty, Black Tie commits itself to render each and every object unique: each seat is rigorously made by hand and controlled in every minimal detail, and with very limited quantities. Each piece is numbered and accompanied by a passport which describes every single detail, because as we know, it is always the smallest detail that determines the true difference.

"Home is the resort
Of love, of joy, of peace, and plenty; where
Supporting and supported, polished friends
And dear relations mingle into bliss".

James Thomson

-
STORY
01













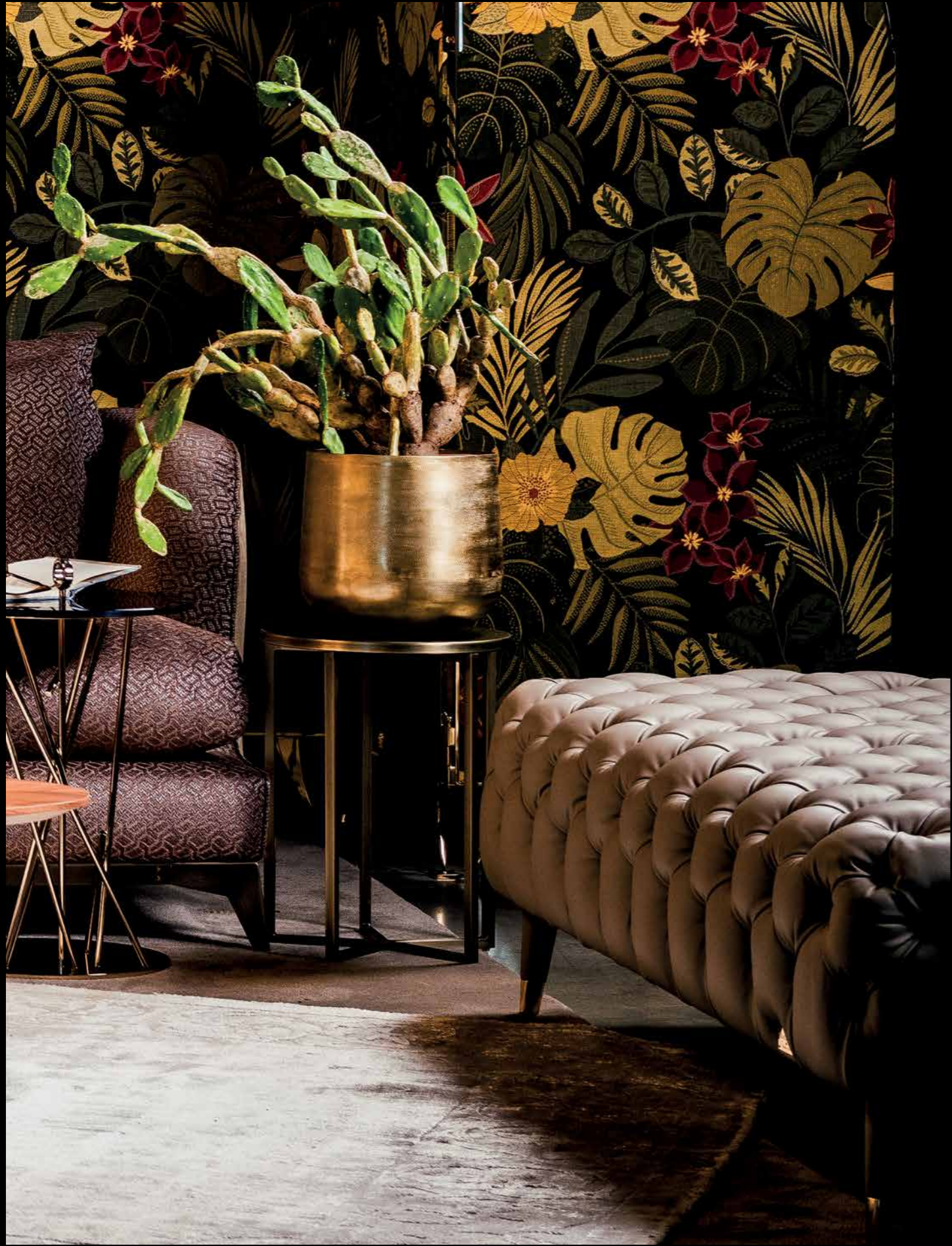



House or home, what matters are details
(details matter)

-
STORY
02



















Some places you never really go away from.
Places where you know you must go back,
places you must recognize yourself.

-
STORY
03







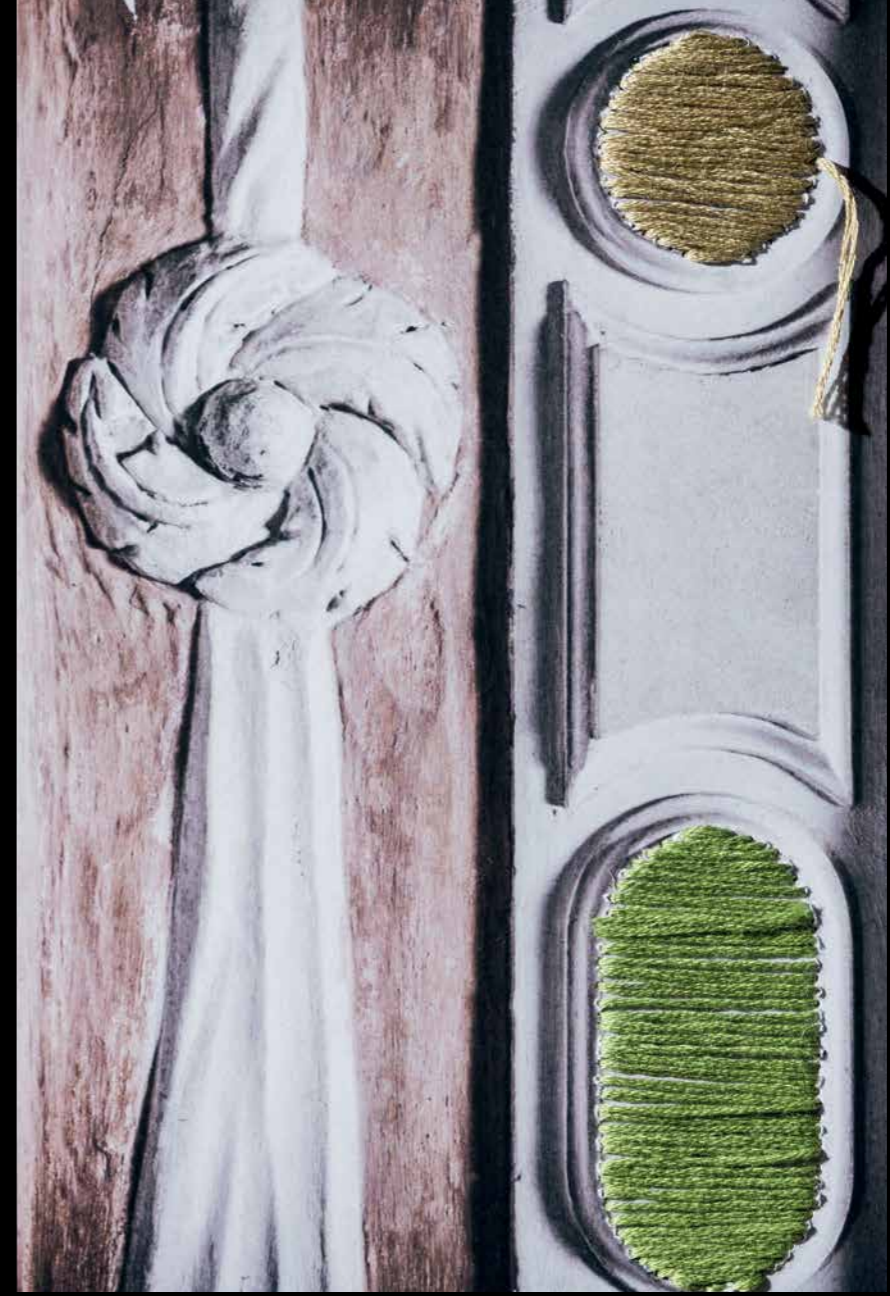



A home is a port of our identity. Peace, tranquility, silence or music, a cigar and our favorite whiskey: home is where we find all that we need.

-
STORY
04









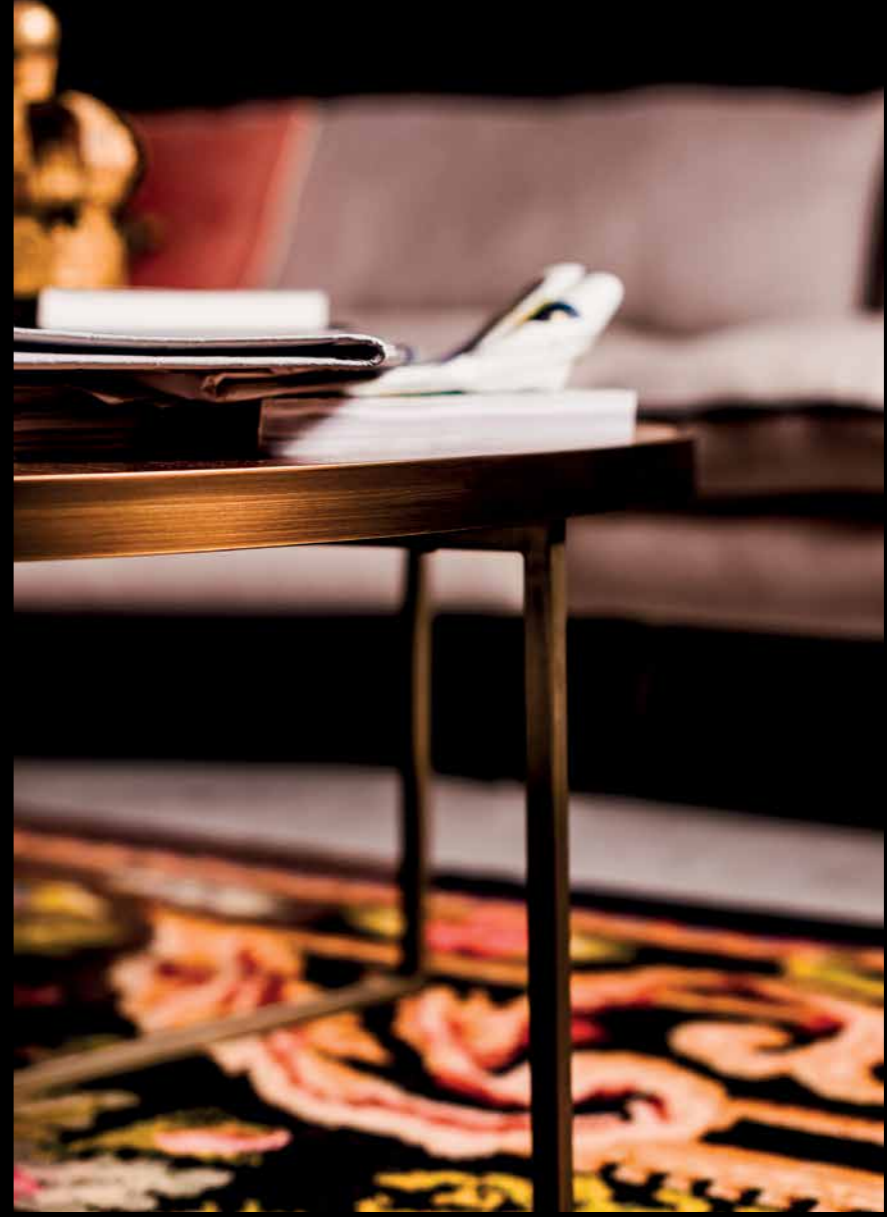



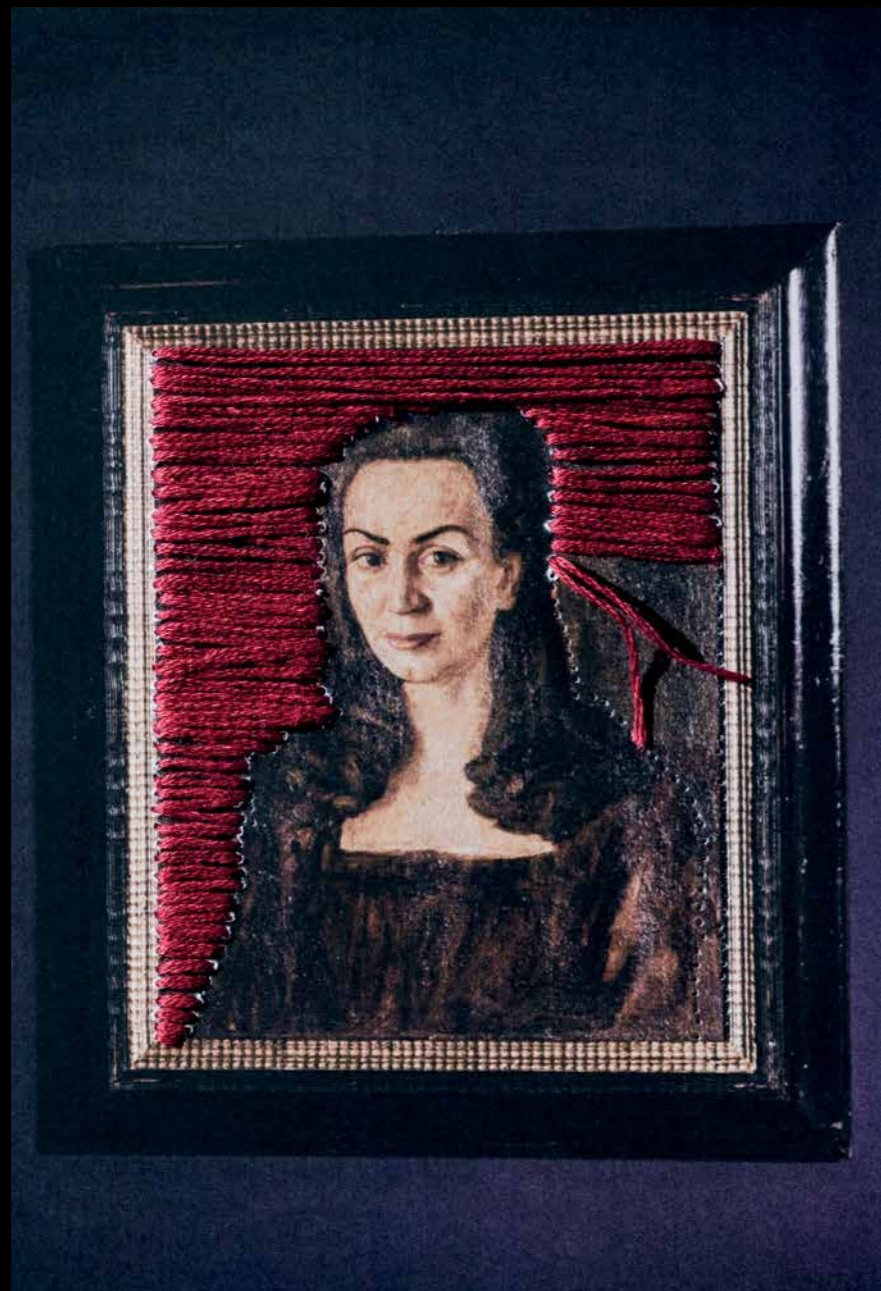



Surrounding yourself with beauty, searching for the difference in details that for others might be insignificant and which instead for you, are home.

-

STORY
05

















When you are unhappy, return to the place that you love the most. He differently from other people always has something to tell you, and will always find a way to console you.

-
STORY
06







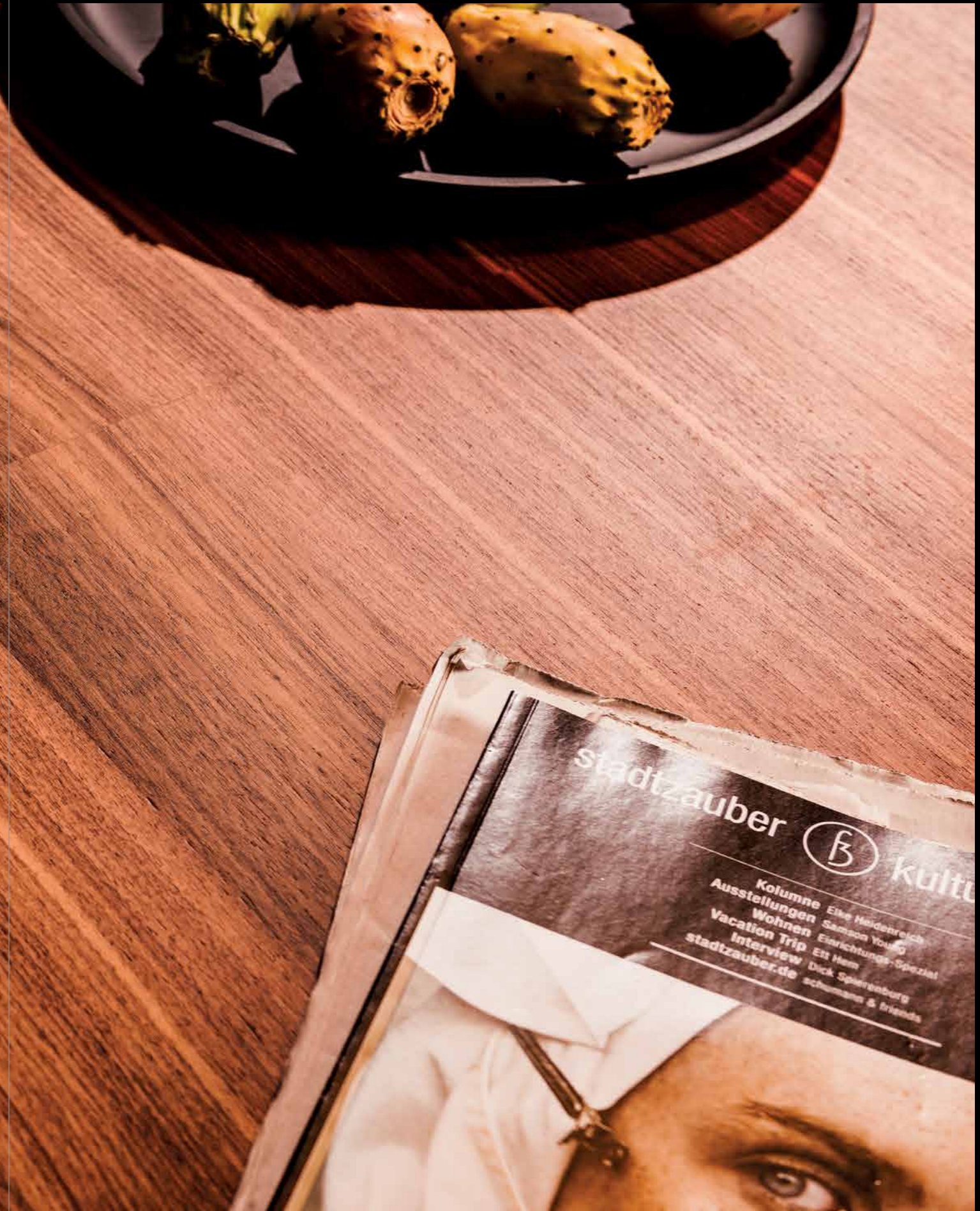
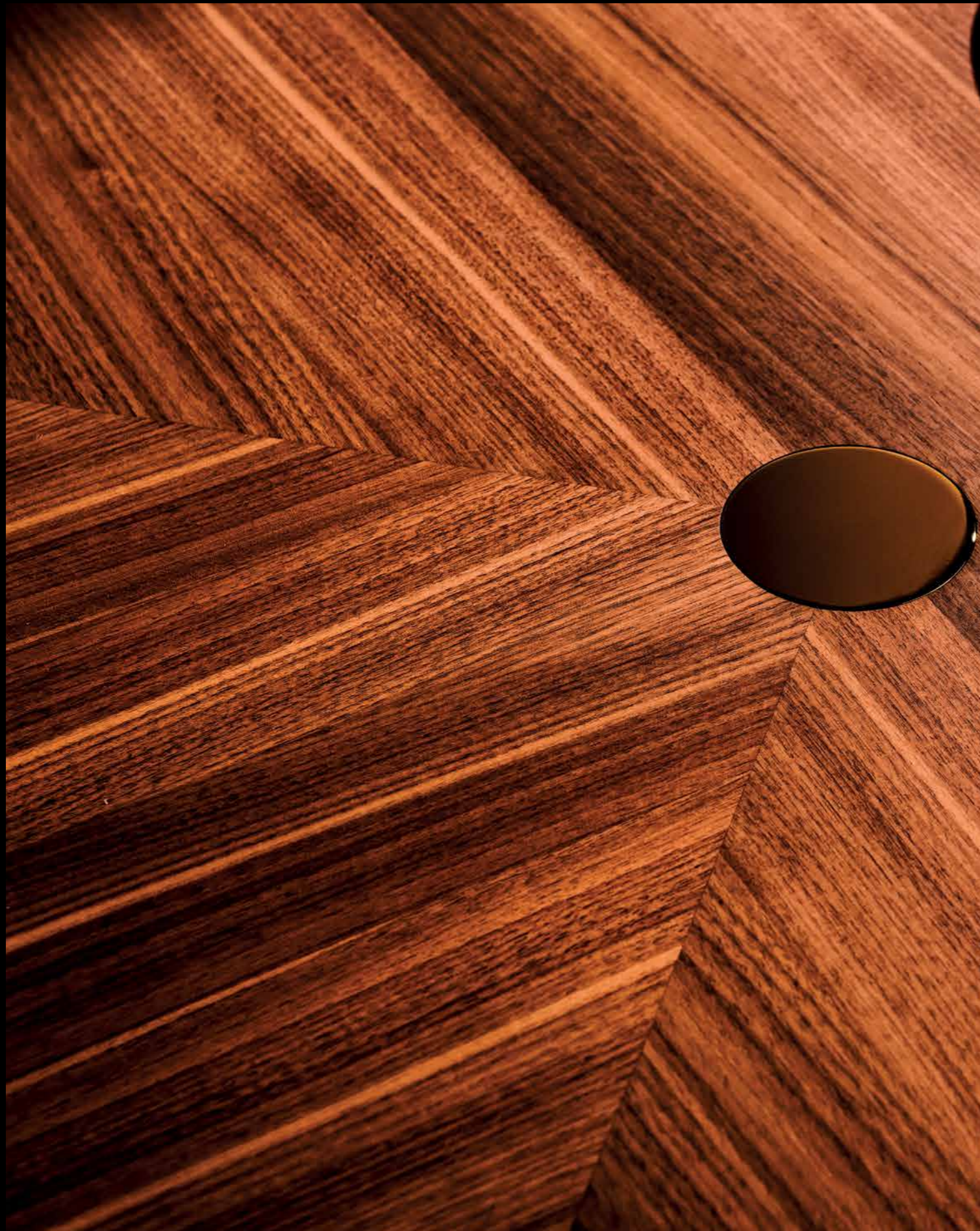







To feel home should signify to feel protected from all fears, from all injuries doubts or disagreements, like a shelter.

-
STORY
07

















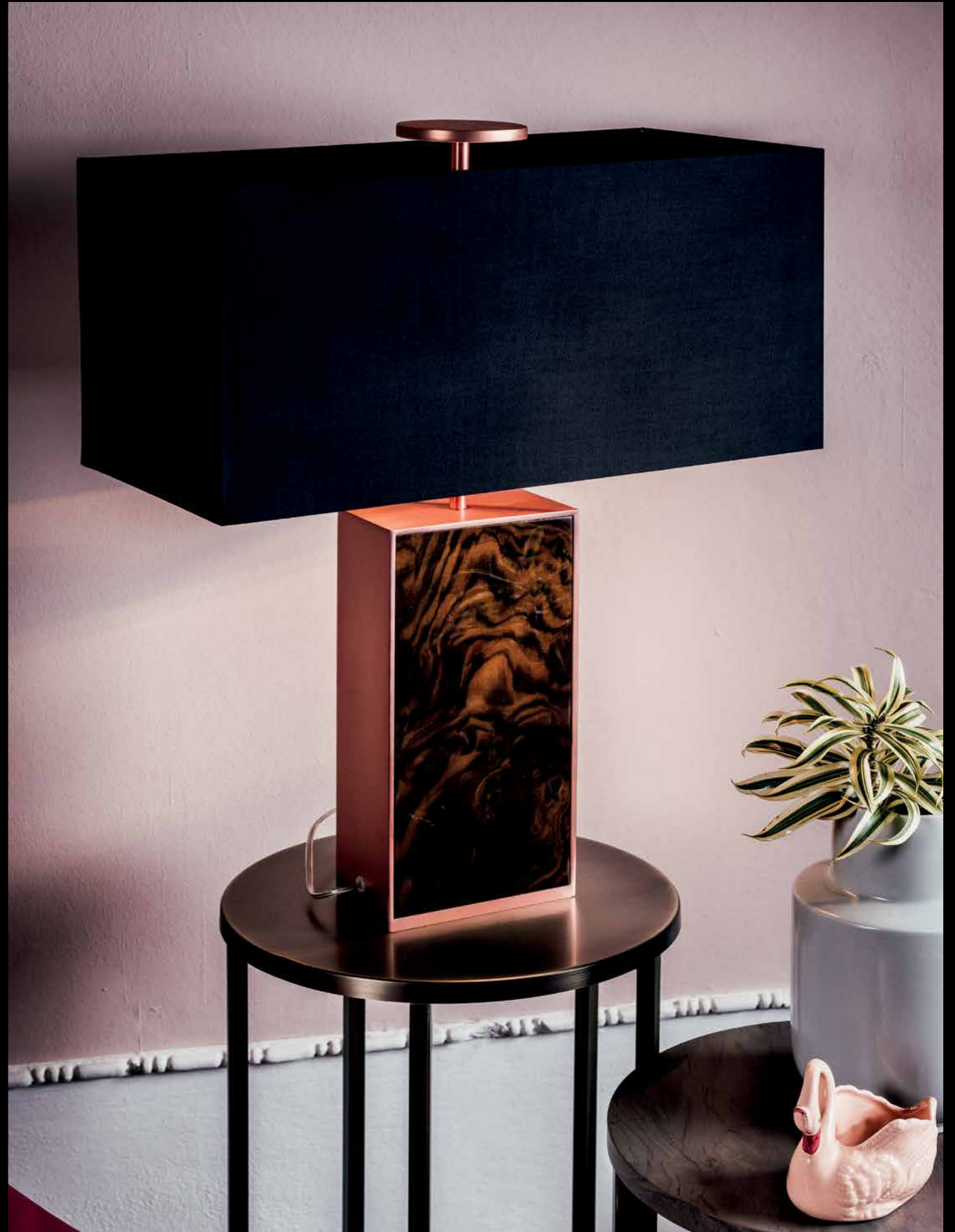

To have time nowadays is luxury.
Time to sit, breathe and dedicate time to those we
love, and to those who make us happy... It is the
small things that can make a day different,
or change an entire life.

-
STORY
08







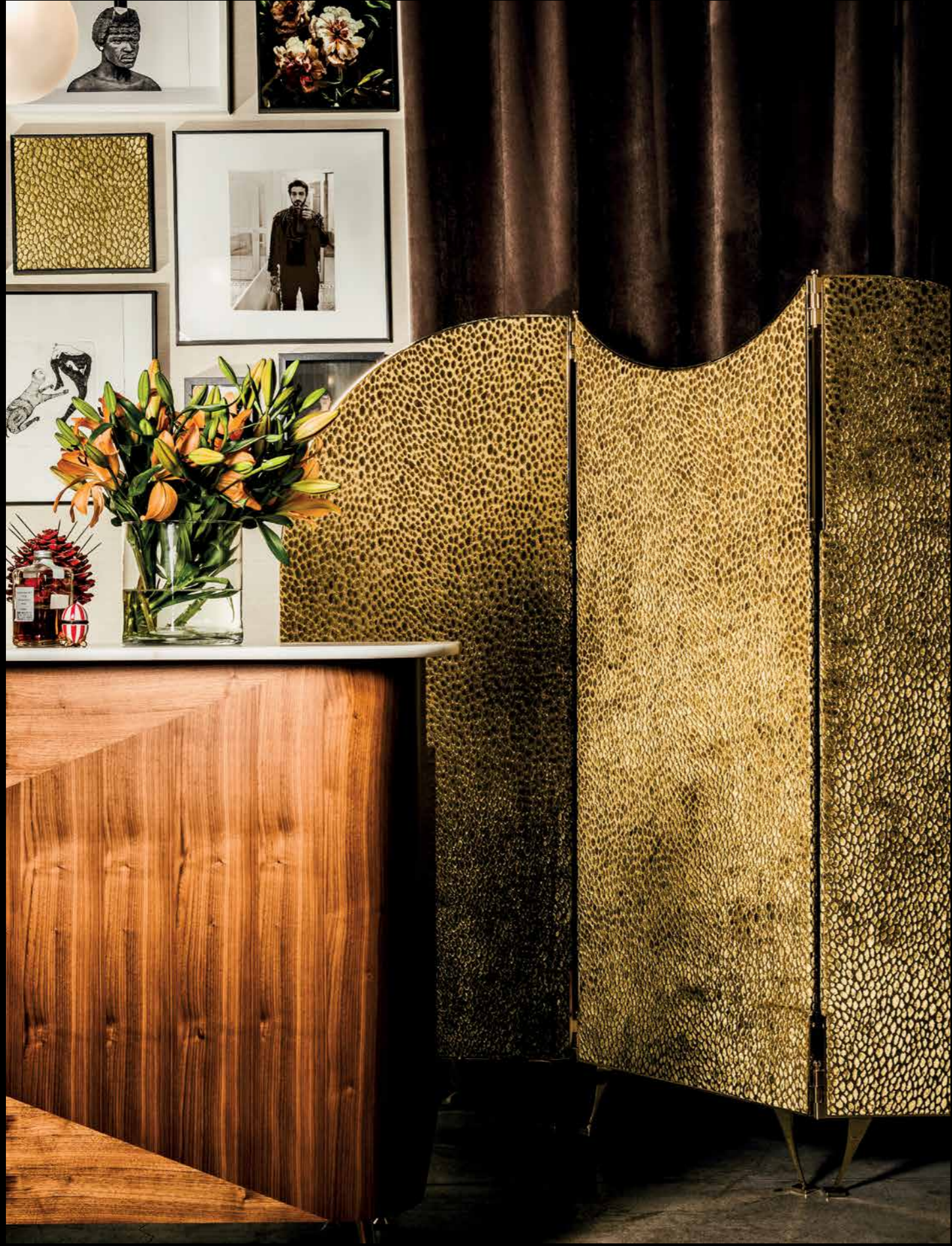



Each choice tells who we are.
Every object is part of us: home is where we have
our heart, home is where we write our life's story.

-
STORY
09















The best part of leaving is knowing that we will return: as soon as we enter, that familiar perfume of books, furniture and people that we love. To return is to recognize that unique scent: the perfume of home.

-
STORY
10





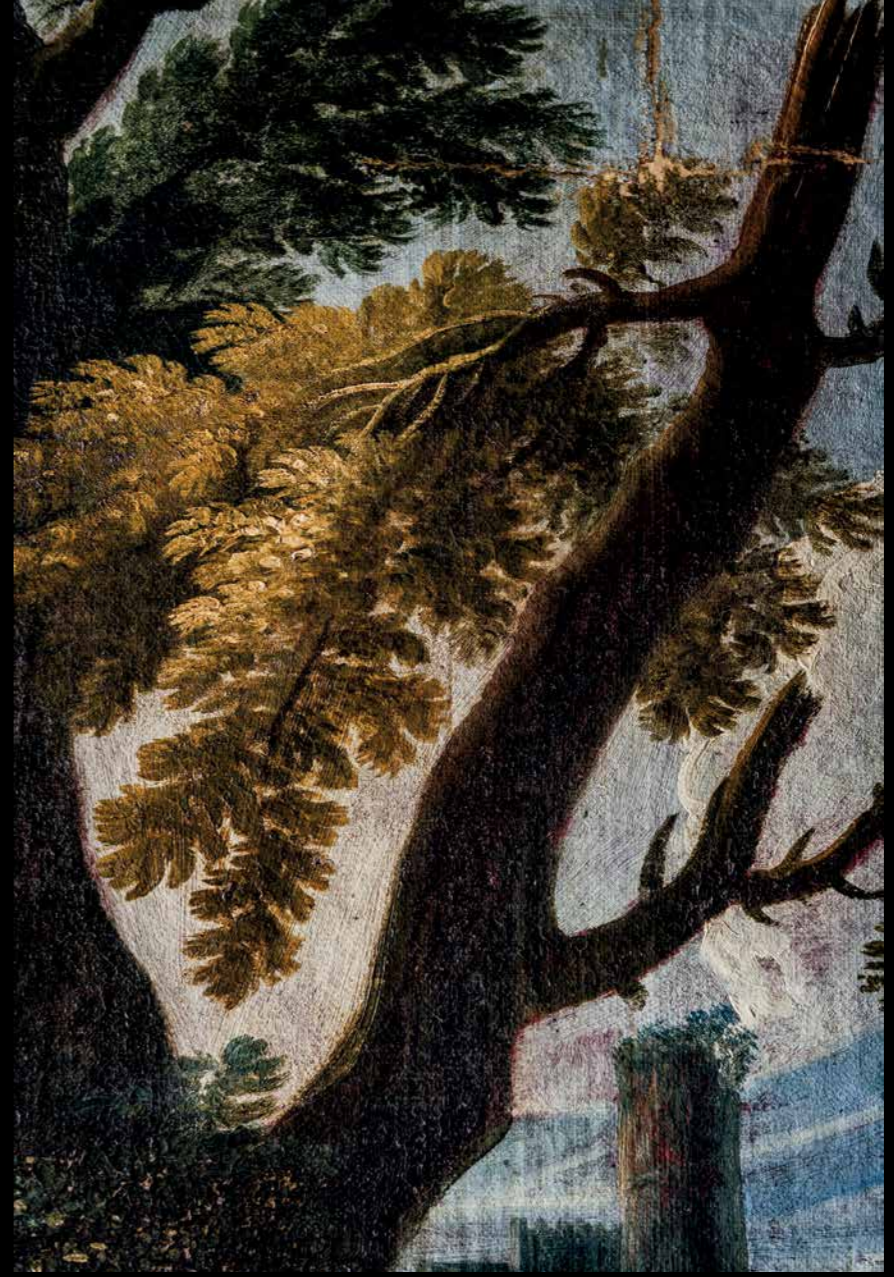













"That is my home of love"

William Shakespeare

-

STORY

11





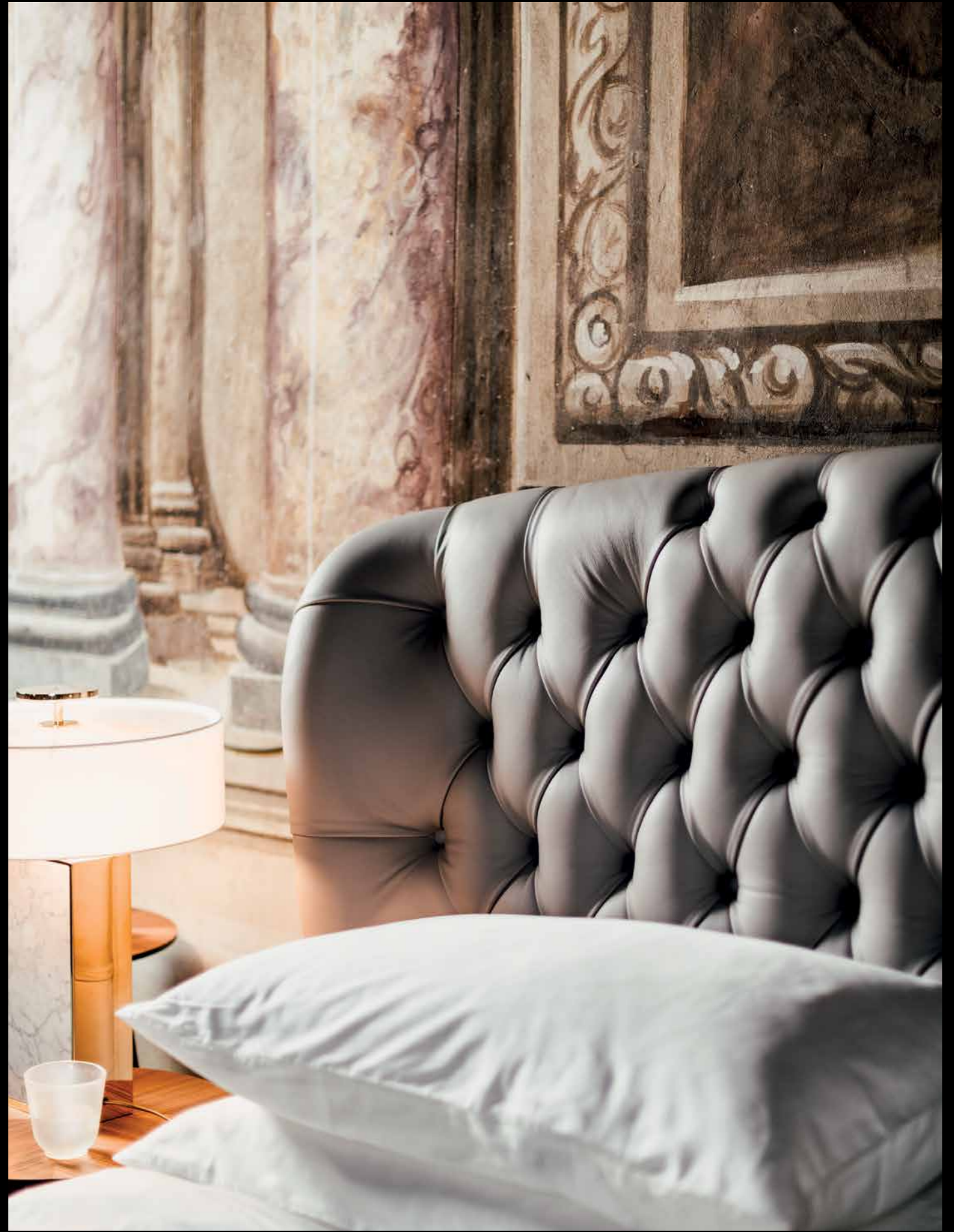

















technical data

sofas _____	179
armchairs _____	245
chairs and stools _____	285
dining tables _____	307
coffee tables _____	327
ottomans and benches _____	359
beds and night table _____	377
lighting _____	387
cabinets and accessories _____	401
outdoor _____	415

sofas

**Alato
Bamboo
Brando
Camillo
Cloè
Dante
Dylan
Giulia
Island
Levante
Martin
Penelope
Savoi
Sebastian**



Alato - Pier Luigi Frighetto, 2011



Modular sofa with structure in metal, with elastic belt spring system stretched over a metal frame. Padding in high-resilience expanded polyurethane, upholstery in thermo-bonded fibre with stretch jersey. Metal armrest padding in high-resilience expanded polyurethane. Seat cushions in 100% European, channelled goose feather, down, closed in independent rooms filling with central insert high-resilience polyurethane foam in different densities and memory foam. Back cushions in 100% European, channelled goose feather, down closed in independent rooms. Fully removable covers in both fabric and leather versions. Feet in shiny stainless steel.

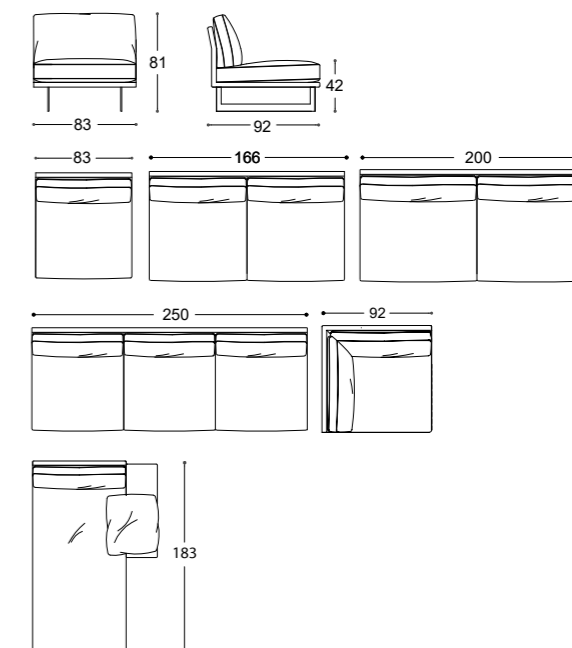





Bamboo - Pier Luigi Frighetto, 2019



Modular sofa with structure in poplar wood. Padding in high-resilience polyurethane foam in different densities and memory foam, crossed elastic belt and upholstery in thermo-bonded fibre with stretch jersey. Base in varnished metal rod. Fully removable fabric cover. Side tables with structure in varnished metal. Top in MDF with Ash moka veneer.

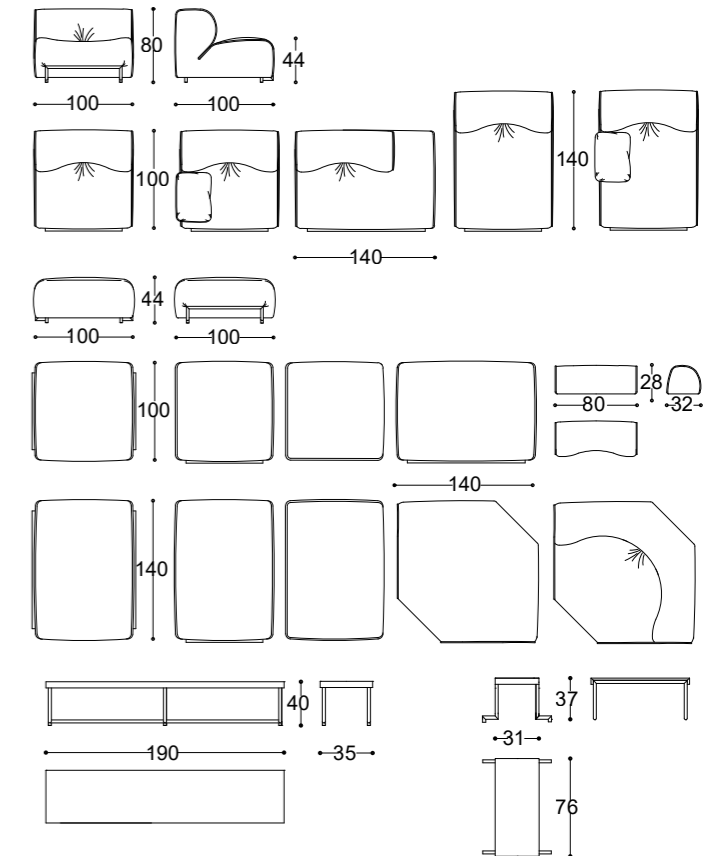





Brando - Pier Luigi Frighetto, 2014



Sofa with structure in fir and poplar wood, with elastic belt spring system. Padding in high-density expanded polyurethane, upholstery in thermo-bonded fibre with stretch jersey. Seat cushions in 100% European channelled goose feather, 10% down, closed in independent rooms, filling with central insert high-resilience polyurethane foam in different densities and memory foam. Back cushions in 100% European channelled goose feather, 10% down, closed in independent rooms. Fully removable fabric covers, only the cushions for the leather version. Base in metal, dark bronze matt finishing.

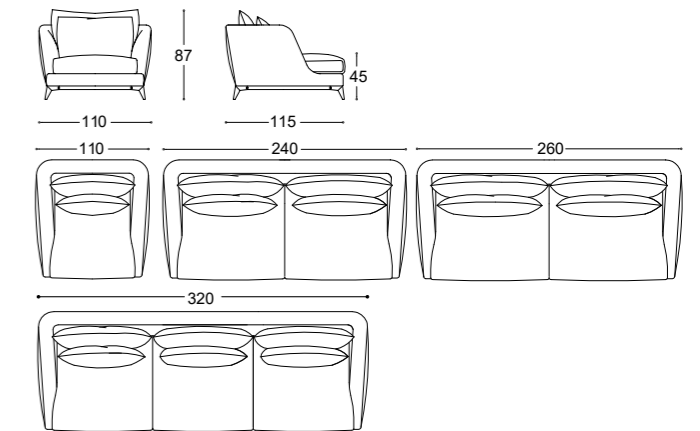







Camillo - Pier Luigi Frighetto, 2011



Modular sofa with structure in fir and poplar wood, with crossed elastic belt spring system. Padding in high-density expanded polyurethane, upholstery in thermo-bonded fibre with stretch jersey. Seat cushions in 100% European, channelled goose feather, 10% down, closed in independent rooms, with central insert in memory foam. Back cushions in 100% European, channelled goose feather, 10% down, closed in independent rooms. Fully removable fabric covers, only the cushions for the leather version.

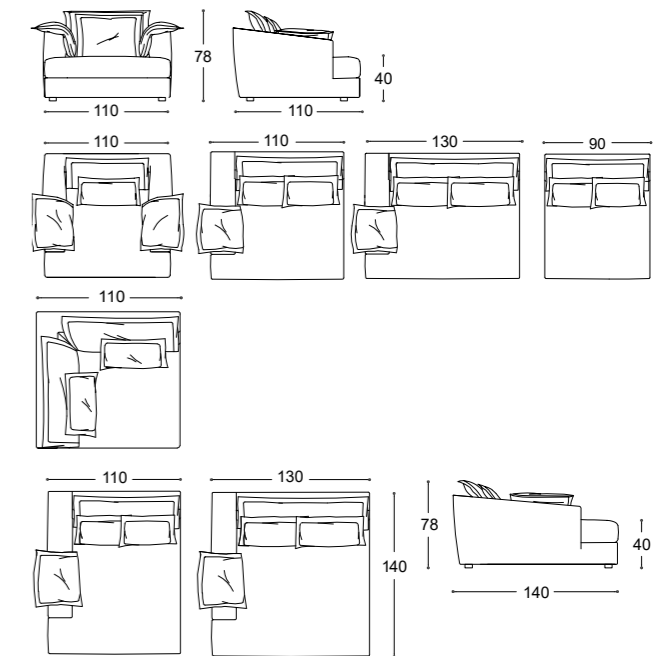





Cloè sofa- Pier Luigi Frighetto, 2015



**Sofa with structure in beech wood,
seat and back in fire-resistant expanded
polyurethane. Feet upholstered.
Non-removable cover.**

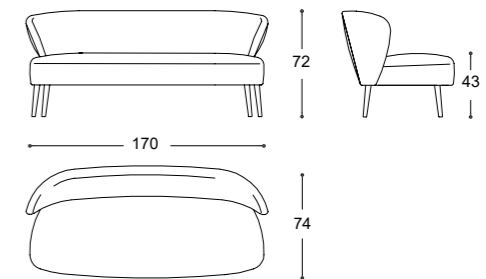



Dante - Pier Luigi Frighetto, 2011



Structure in fir and poplar wood, with crossed elastic belt spring system. Padding in high-density expanded polyurethane, upholstery in thermo-bonded fibre with stretch jersey. Seat cushions in 100% European channelled goose feather, 10% down, with central insert in high-density polyurethane, closed in independent rooms. Back cushions in 100% European, channelled goose feather, 10% down, closed in independent rooms, with central insert in memory foam. Fully removable fabric covers, only the cushions for the leather version.

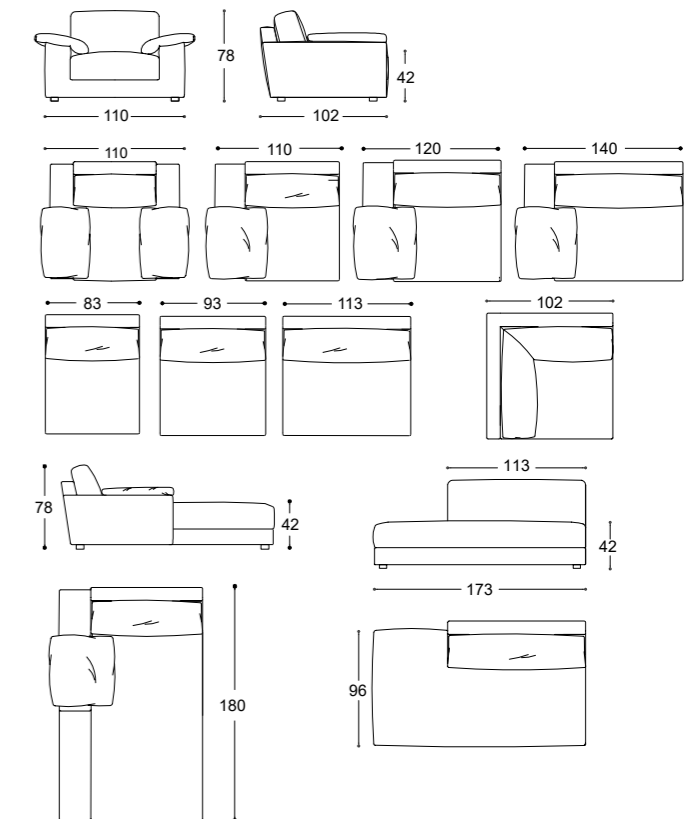







Dylan - Pier Luigi Frighetto, 2018



Sofa with structure in fir and poplar wood, padding in high-resilience polyurethane foam in different densities and memory foam, upholstery in thermo-bonded fibre with stretch jersey. Feet in Canaletto walnut solid wood. Non-removable cover.

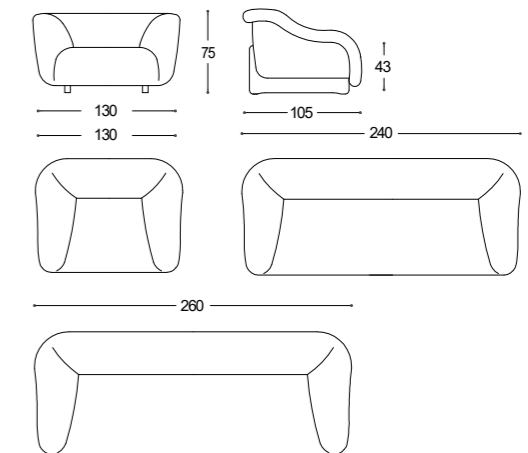





Giulia sofa - Pier Luigi Frighetto, 2017



Sofa with structure in beech wood, seat and back in fire-resistant expanded polyurethane. Metal feet in gold or dark bronze matt galvanic finishing. Removable covers only the cushion.

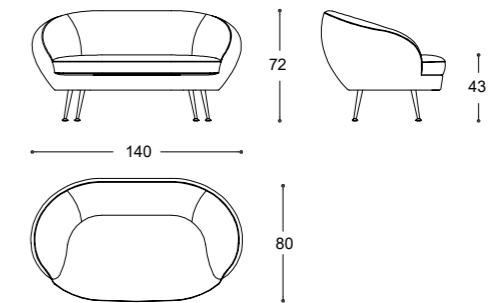



Island - Pier Luigi Frighetto, 2011



Modular sofa with structure in fir and poplar wood and metal, with elastic belt spring system stretched over a metal frame. Padding in high-resilience expanded polyurethane, upholstery in thermo-bonded fibre with stretch jersey. Seat and back cushions in 100% European, channelled goose feather, 10% down, closed in independent rooms, filling with central insert in memory foam. Fully removable fabric covers, only the cushion for the leather version. Feet matt dark bronze finishing.

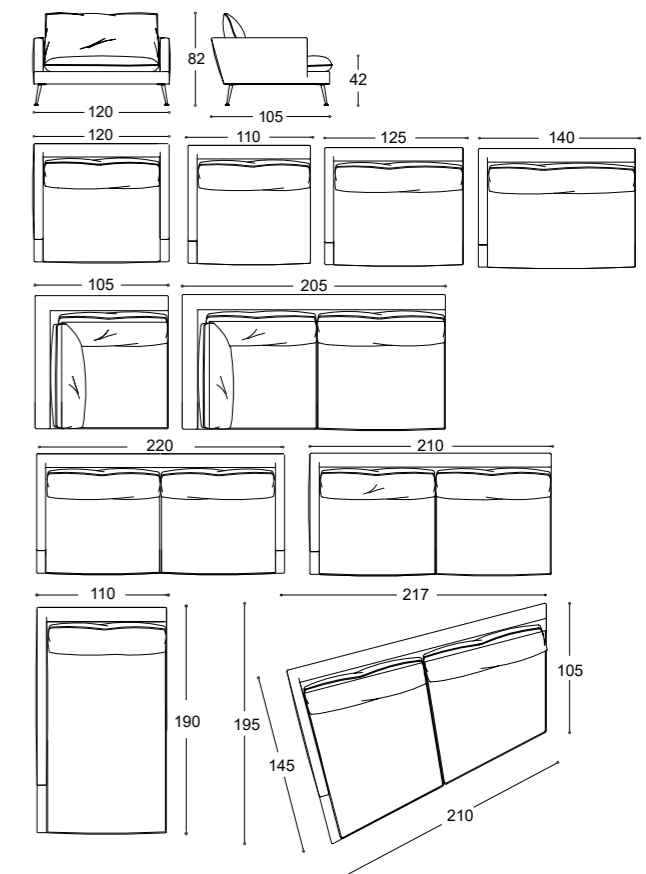









Levante - Pier Luigi Frighetto, 2016



Sofa with structure in poplar wood, with crossed elastic belt spring system. Padding in high-density expanded polyurethane, upholstery in thermo-bonded fibre with stretch jersey. Seat cushions in 100% European channelled down feather, closed in independent rooms, filling with central insert high-resilience polyurethane foam in different densities and memory foam. Back cushions in 100% European channelled down feather, closed in independent rooms. Fully removable fabric covers, only the cushions for the leather version.

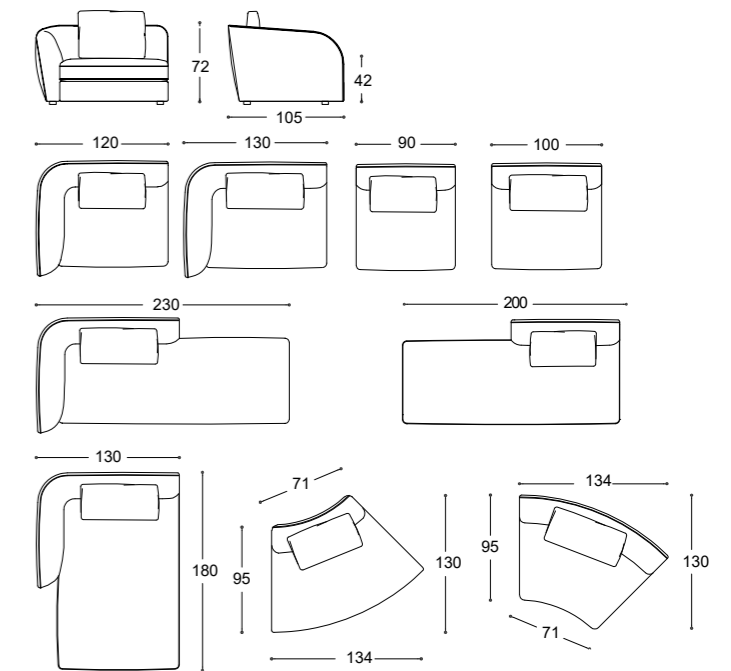









Martin - Pier Luigi Frighetto, 2011



Modular sofa with structure in fir and poplar wood, with crossed elastic belt spring system. Padding in high-density expanded polyurethane, upholstery in thermo-bonded fibre with stretch jersey. Seat cushions in 100% channelled goose feather, 10% down, closed in independent rooms, filling with central insert high-resilience polyurethane foam in different densities and memory foam. Back cushions in 100% European, channelled goose feather, 10% down, closed in independent rooms. Fully removable fabric covers, only the cushions for the leather version.

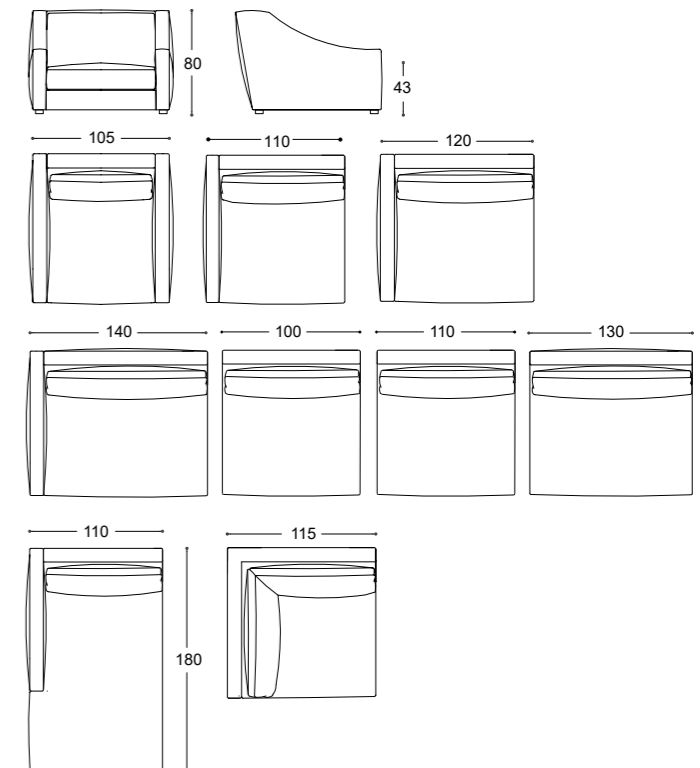







Penelope - Pier Luigi Frighetto, 2017



Sofa with structure in beech wood, seat and back in fire-resistant expanded polyurethane. Tufted back. Feet upholstered with gold metal glides. Non-removable cover.

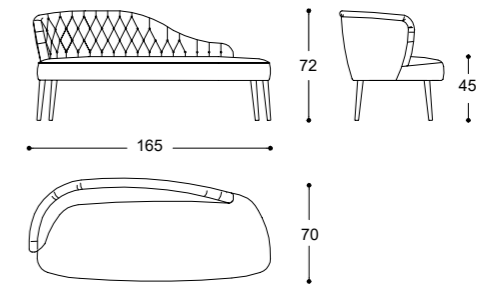



Savoi sofa - Pier Luigi Frighetto, 2015



Sofa with structure in solid wood, with crossed elastic belt spring system. Padding in high-density expanded polyurethane, upholstery in thermo-bonded fibre with stretch jersey. Seat cushions in 100% European channelled goose feather, 10% down, closed in independent rooms, filling with central insert high-resilience polyurethane foam in different densities and memory foam. Tufted back. Feet upholstered with glides in metal gold finishing. Removable only seat cushions.

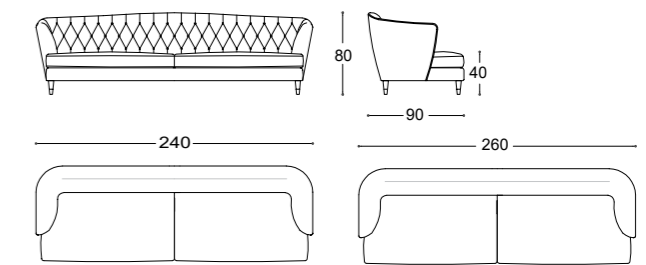





Sebastian - Pier Luigi Frighetto, 2018



Sofa with structure in poplar wood, with crossed elastic belt spring system. Padding in high-resilience polyurethane foam, upholstery in thermo-bonded fibre with stretch jersey. Seat cushions in 100% European, 10% down, channelled down feather, closed in independent rooms, filling with central insert high-resilience polyurethane foam in different densities and memory foam. Back cushions in 100% European channelled down feather, closed in independent rooms. Fully removable fabric covers, only the cushions for the leather version. Feet in wood, black matt lacquered.

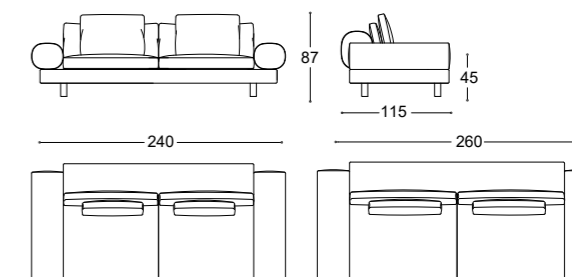



armchairs

Amelia

Anic

Asia

Asia swivel

Asia office

Cloè

Dafne

Frisè

Girò

Giulia

Giulia swivel

Kalida lounge

Miranda

Savoi

Victoria



Amelia - Pier Luigi Frighetto, 2018



Armchair with structure in beech wood, seat and back in fire-resistant expanded polyurethane. Ash moka lacquered wood base. Non-removable cover.

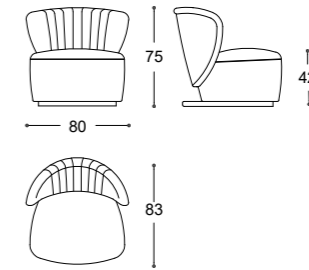



Anic - Pier Luigi Frighetto, 2018



Armchair with structure in beech wood, seat and back in fire-resistant expanded polyurethane. Feet upholstered. Non-removable cover.

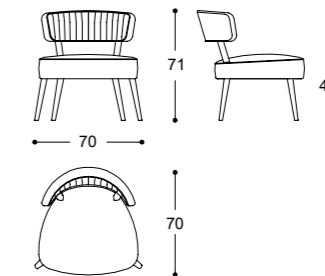



Asia - Pier Luigi Frighetto, 2019



Armchair with frame in matt black-varnished metal rod. Seat, back in curved beech wood, padding in high-resilience expanded polyurethane. Metal glides and armrest in polished gold finishing. Non-removable cover.

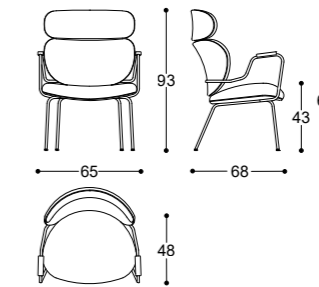



Asia office - Pier Luigi Frighetto, 2019



Armchair with swivel base and seat, back in curved beech wood, padding in high-resilience expanded polyurethane. 5-point-star base in die-cast aluminium, matt black varnished. Soft self-braking castors. Tilting 4 positions. Gas-lift height mechanism. Steel armrest, matt black varnished. Non-removable cover.

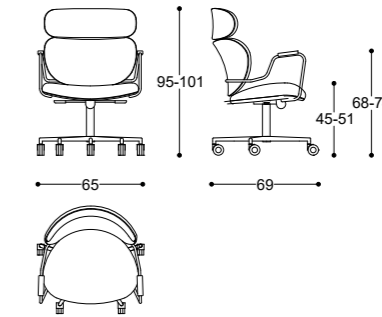



Asia swivel - Pier Luigi Frighetto, 2019



Armchair with swivel base and seat, back in curved beech wood, padding in high-resilience expanded polyurethane. Armrest in steel, polished gold finishing. 4-point-star base in die-cast aluminium, matt black varnished. 360° swivel. Non-removable cover.

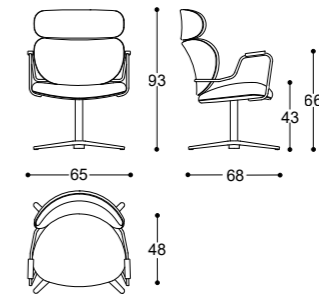



Cloè - Cloè Gold armchair

Pier Luigi Frighetto, 2014



Armchair with structure in beech wood, seat and back in fire-resistant expanded polyurethane.
Feet upholstered. With or without round studs (430).
Non-removable cover.

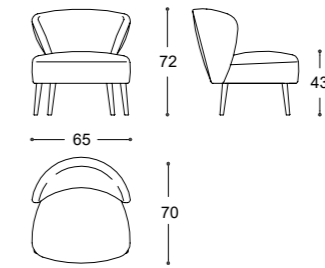



Dafne - Pier Luigi Frighetto, 2012



Armchair with structure in beech wood, with crossed elastic belt spring system. Padding in high-density expanded polyurethane. Seat cushions high resilience polyurethane foam in different densities and memory foam. Structure in oil painted Canaletto wood. Non-removable cover.

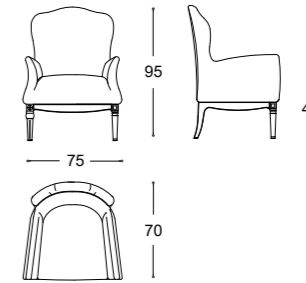



Frisè - Frisè Chaise Lounge

Beatriz Sempere, 2014



Armchair and chaise lounge with structure in Canaletto walnut solid wood, water-based painted. Seat cushions in 100% European, channelled goose feather, 10% down, closed in independent rooms, filling with central insert high-resilience polyurethane foam in different densities and memory foam. Back cushions in 100% European channelled goose feather, 10% down, closed in independent rooms. Seat body in brown hide, backrest body in hand woven brown hide. Fully removable covers, in both fabric and leather.

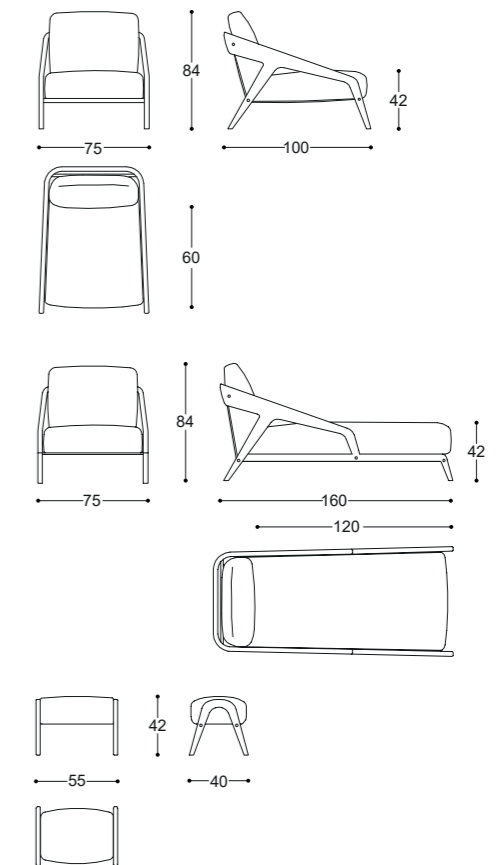



armchairs





Girò

Beatriz Sempere with Pier Luigi Frighetto, 2019



Armchair with structure in solid Ash wood, moka finishing. Seat cushion in high-resilience polyurethane foam combined with BREATHAIR®, a 3D spring structure with rubber elasticity. Upholstery in thermo-bonded fibre with stretch jersey. Metal details in matt gold finishing. Non-removable cover.

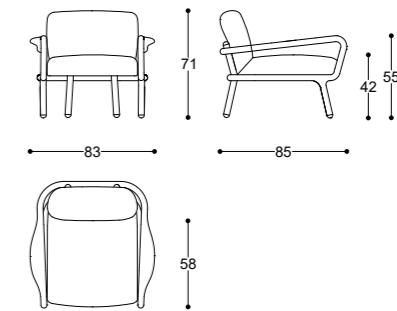





Giulia armchair - Pier Luigi Frighetto, 1985



Armchair with structure in beech wood, padding in high-density expanded polyurethane. Seat cushion in high-resilience polyurethane foam. Metal feet in gold or dark bronze matt galvanic finishing. Removable only the cushions.

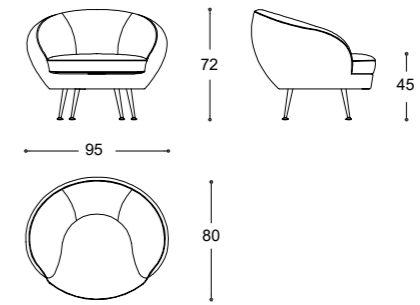



Giulia swivel - Pier Luigi Frighetto, 2018



Armchair with structure in beech wood, padding in high-density expanded polyurethane. Seat cushion in high-resilience polyurethane foam. Swivel base (90° left and 90° right with return). Removable cover only the cushions.

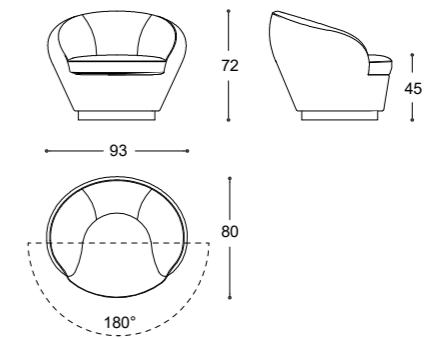



Kalida lounge - Pier Luigi Frighetto, 2018



Armchair with base in matt black varnished metal rod. Seat, back in curved beech wood, padding in high-resilience expanded polyurethane. Metal glides and armrest (optional) in polished gold finishing. Non-removable cover.

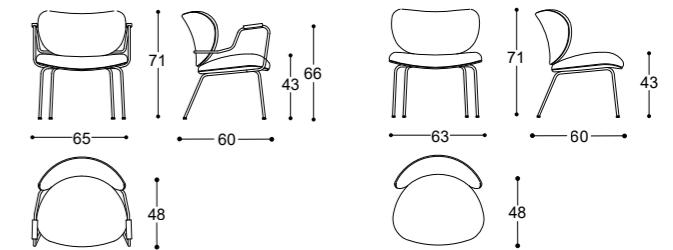

armchairs



Miranda - Pier Luigi Frighetto, 2011



Armchair with structure in fir and poplar wood, with helical steel spring. Padding in high-resilience expanded polyurethane. Seat cushions in 100% European, channelled goose feather, 10% down, closed in independent rooms, filling with central insert high-resilience polyurethane foam in different densities and memory foam. Back cushions in 100% European, channelled goose feather, 10% down, closed in independent rooms. Removable covers in both fabric and leather cushion. Feet in metal oxidize finishing.

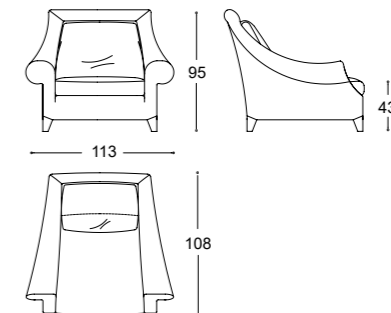



Savoi armchair- Pier Luigi Frighetto, 2015



Armchair with structure in solid wood, with crossed elastic belt spring system. Padding in high-resilience expanded polyurethane in different densities. Tufted rear back (optionally). Feet upholstered with glides in metal gold finishing. Non removable cover.

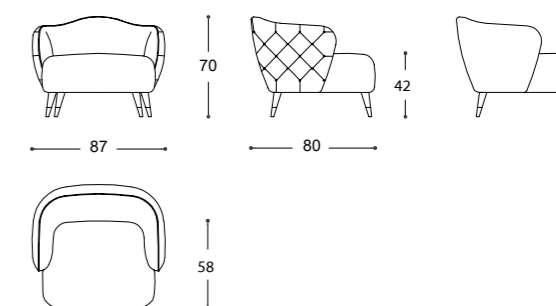





Victoria - Pier Luigi Frighetto, 2011



Armchair with structure in fir and poplar wood, with crossed elastic belt spring system. Padding in high-resilience expanded polyurethane, upholstery in thermo-bonded fibre with stretch jersey. Seat cushions in 100% European, channelled goose feather, 10% down, closed in independent rooms, filling with central insert high-resilience polyurethane foam in different densities and memory foam. Deep, button-padded upholstery, removable cover for seat. Base structure and feet in dark bronze matt.

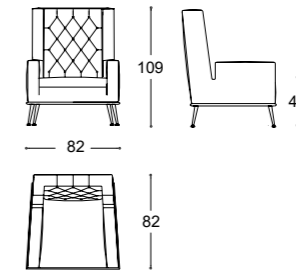

chairs and stools

Cloè
Kalida
Kalida swivel
Kalida office
kelly
Olivia



Cloè dining - Pier Luigi Frighetto, 2014



Dining chair with structure in beech wood, seat and back in fire-resistant expanded polyurethane. Feet upholstered. Handle in dark bronze matt finishing, optionally. Non-removable cover.

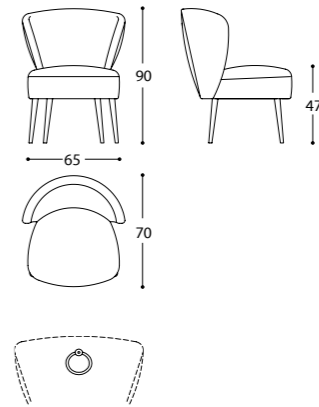



Kalida dining - Pier Luigi Frighetto, 2018



Chair with base in mat black varnished metal rod. Metal glides in polished gold finishing. Seat, back in curved beech wood, padding in high-resilience expanded polyurethane. Metal glides and armrest (optional) in polished gold finishing. Non-removable cover.

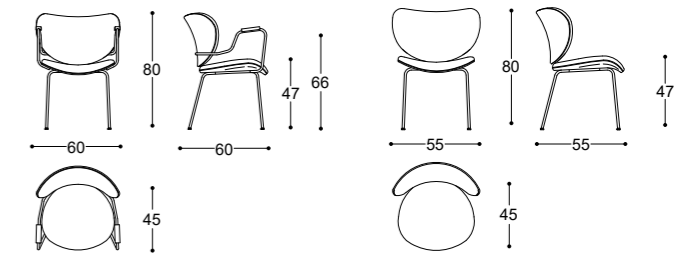







Kalida swivel
Pier Luigi Frighetto, 2019



Swivel chair with seat, back in curved beech wood, padding in high-resilience expanded polyurethane. 4-point-star base in die-cast aluminium, matt black varnished. 360° swivel. Non-removable cover.

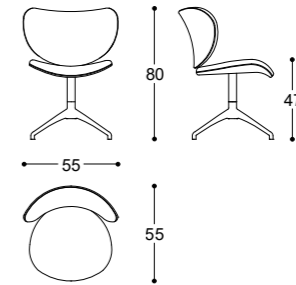



Kalida office - Pier Luigi Frighetto, 2019



Chair with swivel base (with return) Seat and back in curved beech wood, padding in high-resilience expanded polyurethane. 5 point-star base in die-cast aluminium, matt black varnished. With or without soft self-braking castors. Non-removable cover.

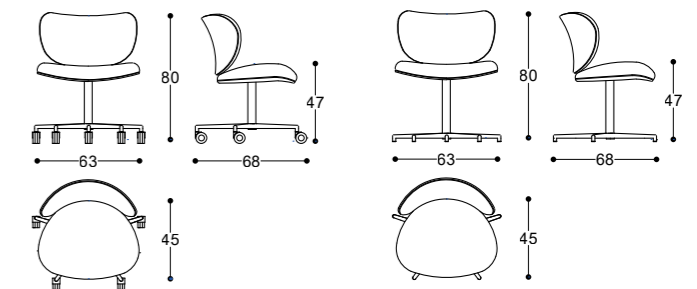



Kelly - Pier Luigi Frighetto, 2019



Chair with seat, back in curved beech wood, padding in high-resilience expanded polyurethane. Legs in solid Ash, moka lacquered. Non-removable cover.

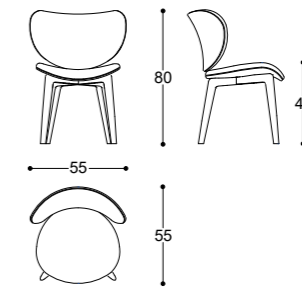



Olivia dining and stool

Pier Luigi Frighetto, 2016



Dining chair and stool (swivel version available) with structure in solid beech wood, padding in fire-resistant expanded polyurethane. Legs in solid ash, moka lacquered with metal glides and footrest in gold or dark bronze matt finishing.

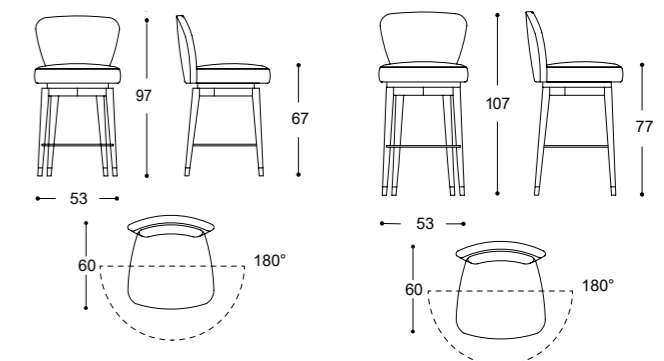
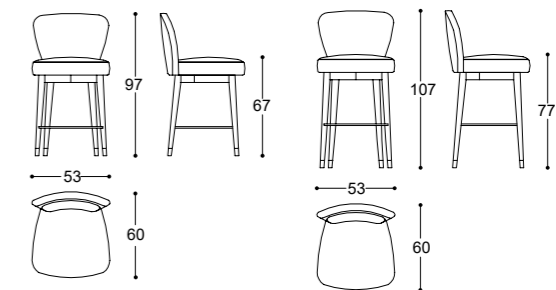
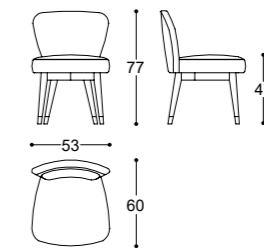





dining tables

Edison

Opera

Santiago



Edison - Enrico Pasa, 2019



Dining table with supporting structure in Canaletto walnut or Ash moka solid wood, top in MDF with Canaletto walnut or Ash moka veneer. Matt gold finishing metal base.

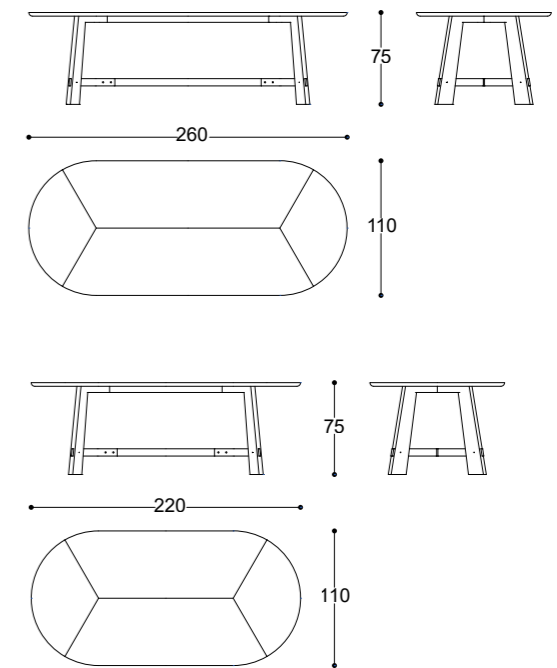

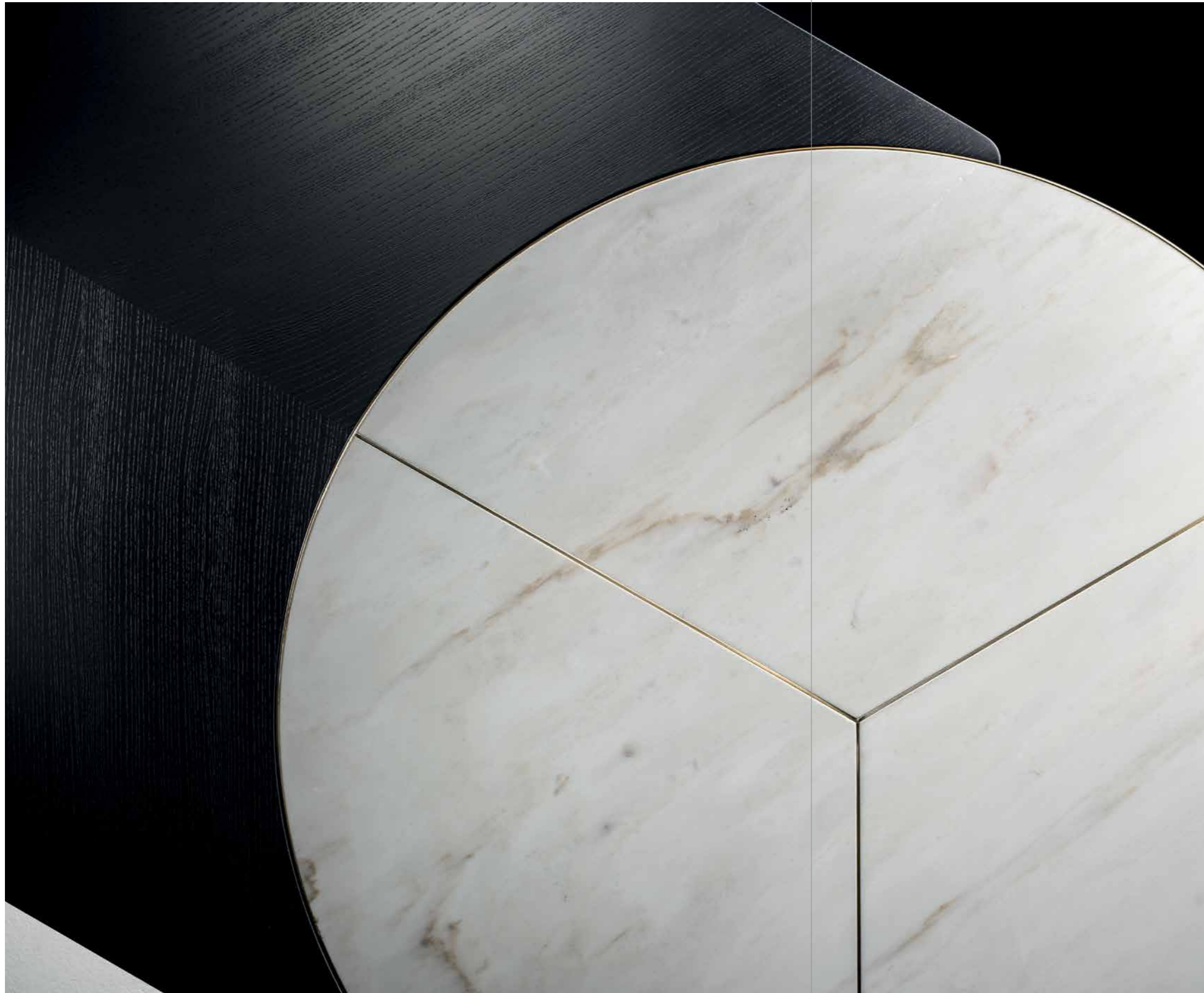

Opera - Enrico Pasa, 2019



Dining table with supporting structure in canaletto walnut or Ash moka solid wood, top in MDF with Canaletto walnut or Ash moka veneer, round top in Onice Capuccino or Calacatta Vagli oro marble with brass details. Matt gold finishing metal base.

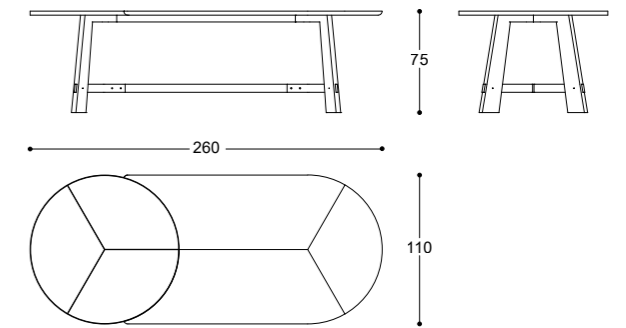









Santiago - Beatriz Sempere, 2017



Dining table with supporting structure in birch plywood and top in MDF Canaletto walnut finishing with metal gold finishing parts.

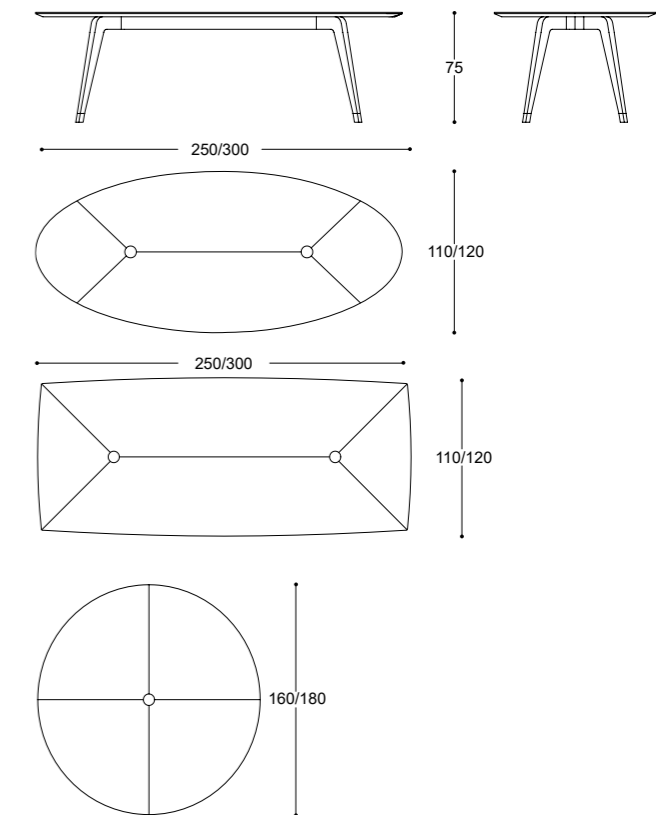

dining tables







coffee tables

Elliot
Elliot Plus
Hugo
Lin
Manolo
Milton
Oleg
Pablo
Samuel
Tao
Tommi



Elliot - Pier Luigi Frighetto, 2014



Round tables with structure in metal, dark bronze matt finishing. Top in Elegant Brown stone and Calacatta Vagli Oro. In the small version top in dark bronze matt or polished gold finishing.

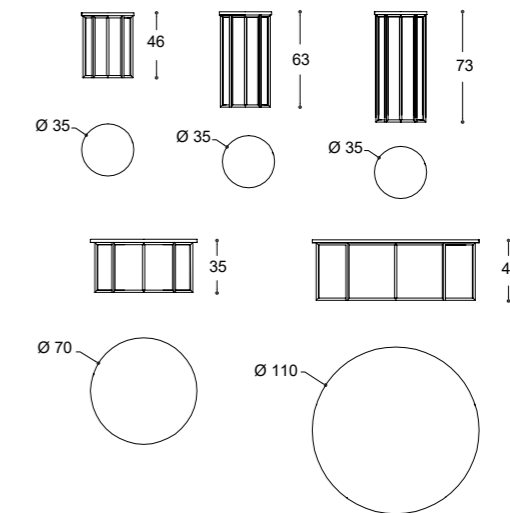





Elliot Plus - Pier Luigi Frighetto, 2017



Round side tables with structure in metal, dark bronze matt or gold finishing. Top in Canaletto walnut wood.

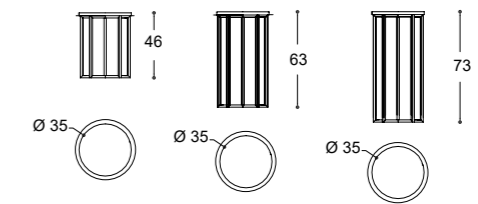





Hugo - Pier Luigi Frighetto, 2012



Coffee table with supporting structure in metal, oxidize finishing. Top in Elegant Brown stone or Calacatta marble.

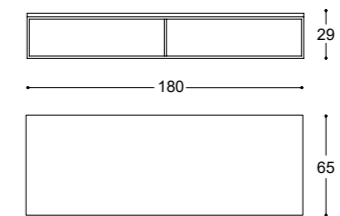



Manolo - Pier Luigi Frighetto, 2018



Coffee table with supporting structure in Canaletto walnut or Ash moka finishing solid wood. Tempered smoked grey glass top, 10mm thick. Gold finishing metal details.

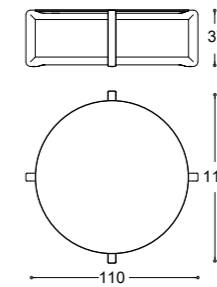



Milton - Beatriz Sempere, 2017



Coffee table with supporting structure in birch plywood Canaletto walnut finishing.
Top in MDF Canaletto walnut finishing with metal gold finishing glides.

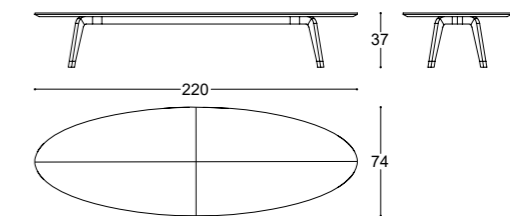



Oleg - Pier Luigi Frighetto, 2015



Coffee table with supporting structure in metal dark bronze finishing. Top in MDF Canaletto walnut finishing.

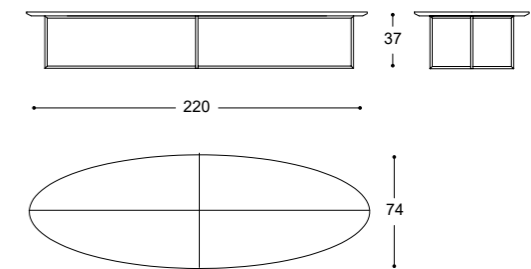



Lin - Alatere Collateral Design, 2019



Console with structure in stainless steel polished gold finishing, back lacquered glass top dark blue.

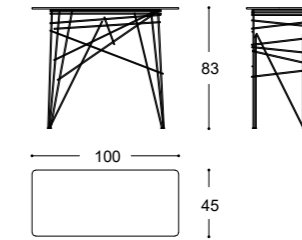



Pablo - Pier Luigi Frighetto, 2015



Tables with supporting structure in metal oxidize finishing. Top in Elegant Brown stone or Calacatta Vagli Oro marble.

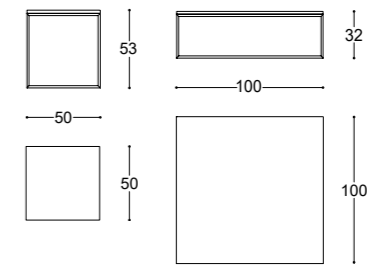



Samuel - Pier Luigi Frighetto, 2017



Round tables with structure in metal dark bronze matt finishing. Top in MDF Canaletto walnut finishing.

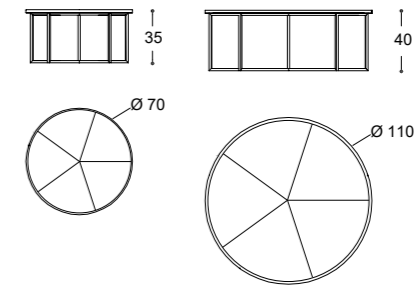



coffee tables



Tao - A-latere Collateral Design, 2017



Small table with structure instainless steel polished gold, back lacquered glass top, green, red, dark blue.

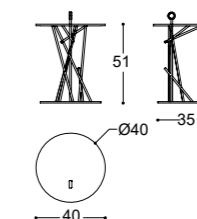

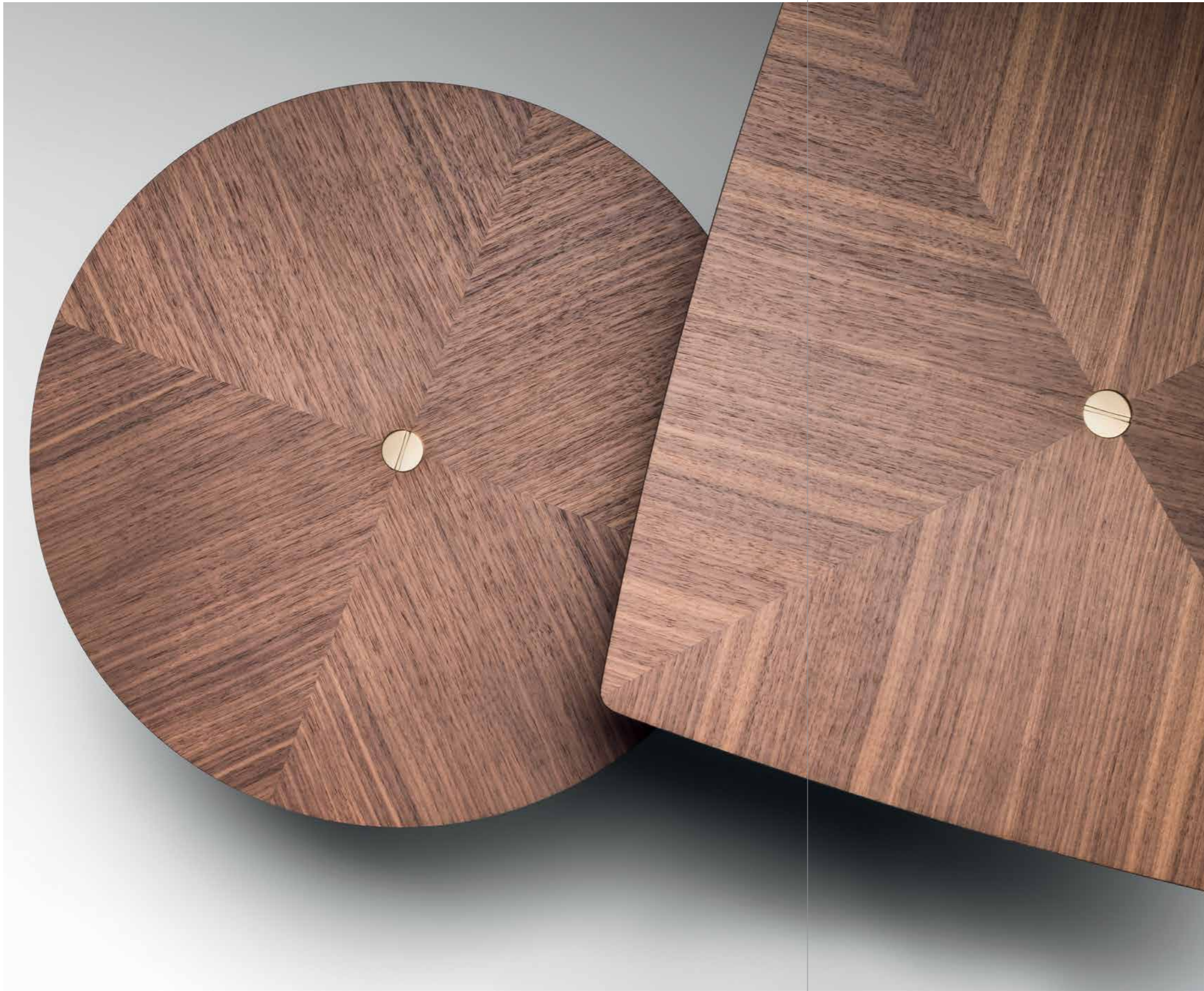

Tommi tables - Beatriz Sempere, 2015



**Side tables and consoles with supporting structure in Canaletto walnut solid wood.
Top in MDF Canaletto walnut finishing with central insert in metal gold finishing.**

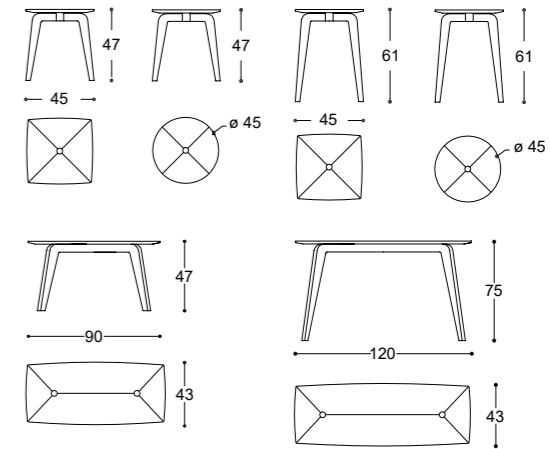



ottomans and benches

Casablanca

Cubo

Noah

Olivia

Rondò

Savoi

Timoty

Tommi



Casablanca - Pier Luigi Frighetto, 2011



Pouf with structure in multi-layered poplar. Padding in high-resilience polyurethane foam in different densities. Upper padding 100% European feather. Hand-sewn leather cover. Non removable cover.

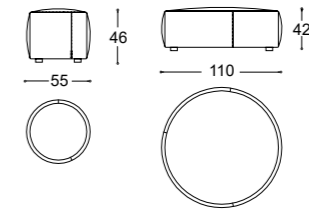



Cubo - Pier Luigi Frighetto, 2011



Pouf collection with structure in multi-layered poplar. Padding in high-resilience expanded polyurethane, covered with 100% European channelled goose feather. Fully removable cover in fabric, non-removable in leather version.

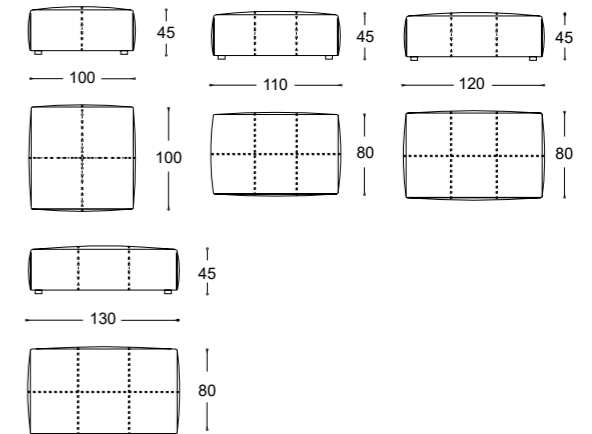



Noah - Alatere Collateral Design, 2019



Ottoman with structure in poplar wood.
Padding in high-resilience polyurethane foam in different densities. Upholstery in thermo-bonded fibre with stretch jersey. Metal element in polished gold finishing, base in black laquered MDF.
Fully removable fabric cover.
Non-removable leather cover.

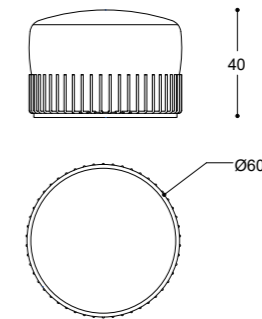



Olivia bench - Pier Luigi Frighetto, 2016



Bench with structure in solid beech wood. Padding in high resilience polyurethane foam. Non-removable cover. Legs in solid ash, moka lacquered with metal glides.

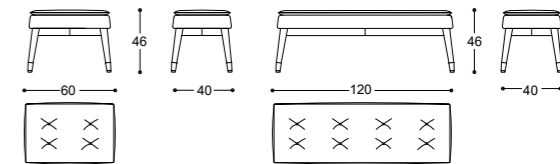



Rondò - Pier Luigi Frighetto, 2011



Pouf collection with structure in multi-layered poplar. Padding in high-resilience polyurethane foam in different densities and memory foam. Upper padding 100% European, goose feather. Fully removable fabric cover. Non-removable leather cover.

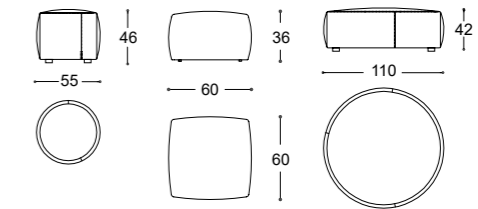



Savoï bench - Pier Luigi Frighetto, 2015



Pouf with structure in fir and poplar wood. Padding in high-resilience polyurethane foam in different densities. Deep, button-padded upholstery, non removable cover. Feet upholstered with glides metal polished gold finishing.

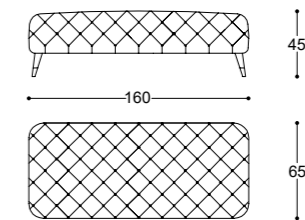



Timoty - Pier Luigi Frighetto, 2011



Bench with structure in fir and poplar wood. Padding in high-resilience polyurethane foam in different densities. Deep, button-padded upholstery, non removable cover. Black lacquered metal structure and feet.

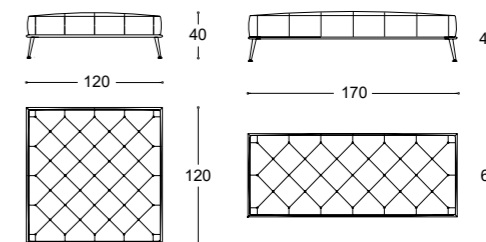



Tommi pouf - Beatriz Sempere, 2017



**Pouf with structure in fir and poplar wood.
Padding in high-resilience polyurethane foam.
Legs in Canaletto solid wood.**

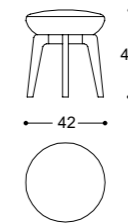

beds and night table

Alfio
Toledo
Savoi



Alfio - Pier Luigi Frighetto, 2015



**Bedside table, structure in solid Ash, moka finishing.
Top in MDF with Ash moka veneer.
Metal glides in polished gold finishing.**

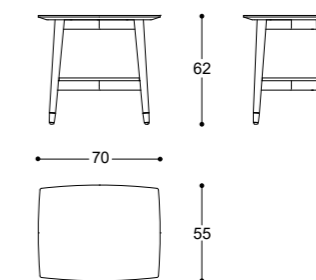



Toledo - Pier Luigi Frighetto, 2019



Bed with headboard and bed frame in poplar wood, padding in high-density expanded polyurethane, upholstery in thermo-bonded fibre with stretch jersey. Matt gold finishing MDF details. Wooden slatted base with rigidity adjusters. Fully removable covers only in fabric.

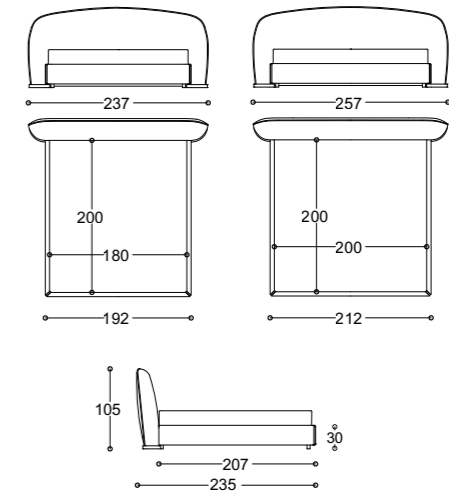

King and Queen size bed available upon request





Savoi bed - Pier Luigi Frighetto, 2015



Headboard and bed frame in poplar wood, padding in high-density expanded polyurethane, upholstery in thermo-bonded fibre with stretch jersey. Capitonè upholstered headboard in polyurethane foam in different densities. Wooden slatted base. Feet upholstered with glides in metal gold finishing. Non-removable cover.

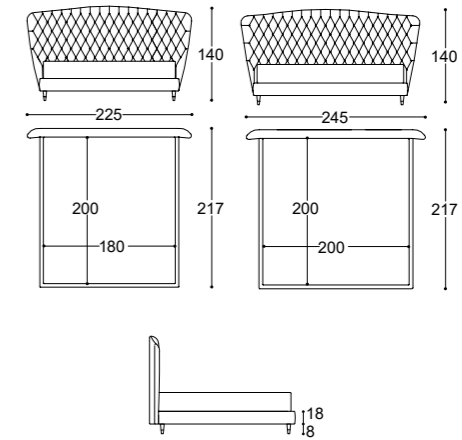

King and Queen size bed available upon request

lighting

Diva
Lucy
Maite
Nadine
Thelma
Tosca



Diva - Black Tie Studio, 2018



Table lamp for diffused or downward lighting with central body in Emperador marble, metal elements dark bronze matt finishing. Brown lampshade. Light source: 2XE27 (Led bulbs suggested).

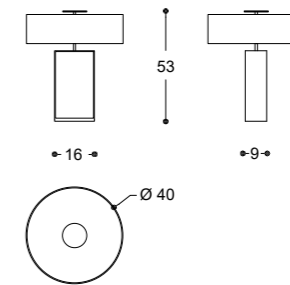



Lucy - Alatere Collateral Design, 2019



Decorative table lamp providing diffuse light with black matt lacquered base and metal elements in polished gold finishing. Spherical diffuser in glossy opal glass. Bulbs: 1XE27 (bulb is not included, suggested LED bulb). Plug type A (USA), type F (EU-schuko) or type G (UK). CE certified.

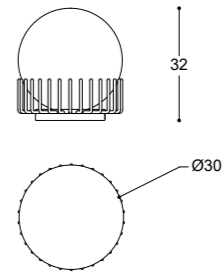



Maite - Pier Luigi Frighetto, 2017



Table lamp for diffused or downward lighting with central body in glossy walnut root, metal elements in rose gold matt. Black cotonette lampshade.
Light source: 2XE27 (Led bulbs suggested)

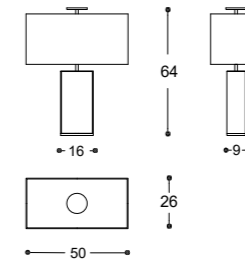



Nadine - Black Tie Studio, 2015



Table lamp for diffused or downward lighting. Wood base dark blue lacquered, metal elements polished gold. Brown lampshade, internal black cottonette. Light source: 2XE27 (Led bulbs suggested).

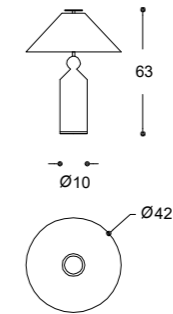



Thelma - Black Tie Studio, 2015



Table lamp for diffused or downward lighting with central body in Carrara marble, metal elements polished gold. White lampshade. Light source: 2XE27 (Led bulbs suggested).

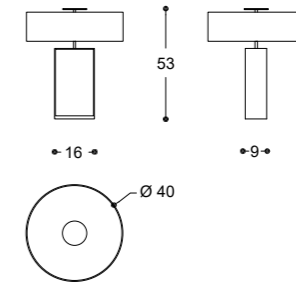



Tosca - Black Tie Studio, 2015



Floor lamp for diffused or downward lighting. Wood base dark blue lacquered, metal elements polished gold. Dark blue lampshade, internal black cottonette. Light source: 2XE27 (Led bulbs suggested).

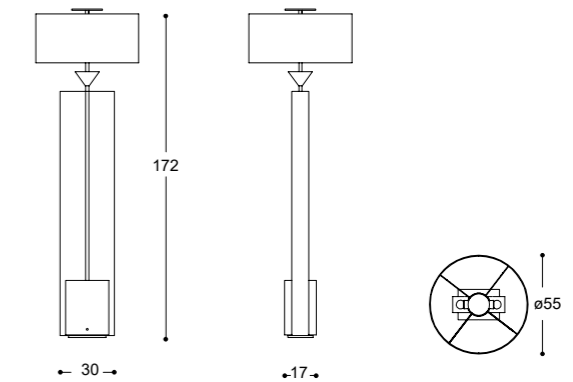

cabinets and accessories

Aliseo
Delta
India
Mou



Aliseo - Marco Corti, 2014



Room divider with structure in multi-layered poplar, padding in high-resilience expanded polyurethane, upholstered in fabric.
Metal frame polished gold finishing.

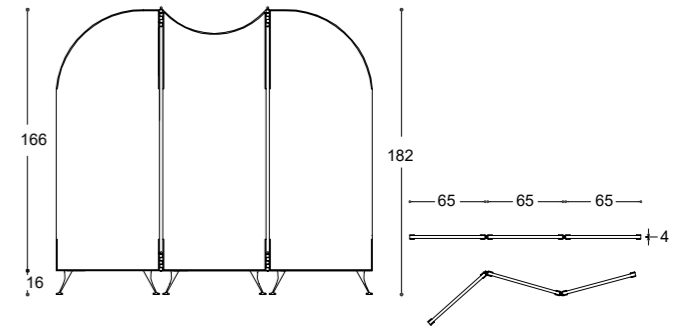



Delta - Pier Luigi Frighetto, 2019



Mirror with structure in black MDF, frame in laser cut metal, gold finishing. Extraclear, bronze and fumè, mirrored glass, with Emperador marble details. Wall mount bracket.

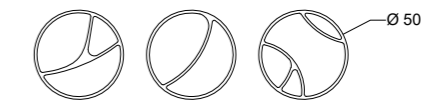



India - Pier Luigi Frighetto, 2019



Sideboard with structure in poplar wood blockboards finished in Ash moka veneer. Round door in MDF, high gloss polyester lacquer finish. Left side and doors in Canaletto walnut or Ash moka. Base and drawer in matt gold finishing.

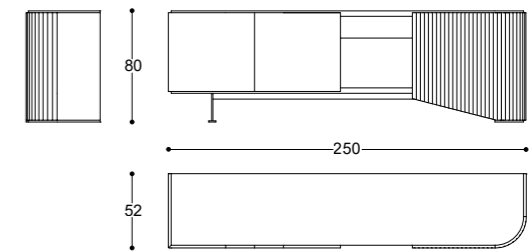





MOU - Beatriz Sempere, 2016



Mirror with structure in black MDF, frame in laser cut metal, dark bronze finishing. Silver, silver bronze, silver grey mirrored glass. Wall mount brackets.

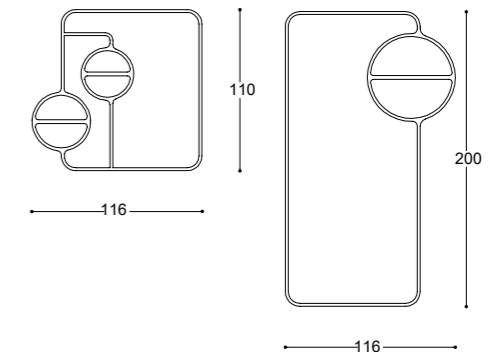

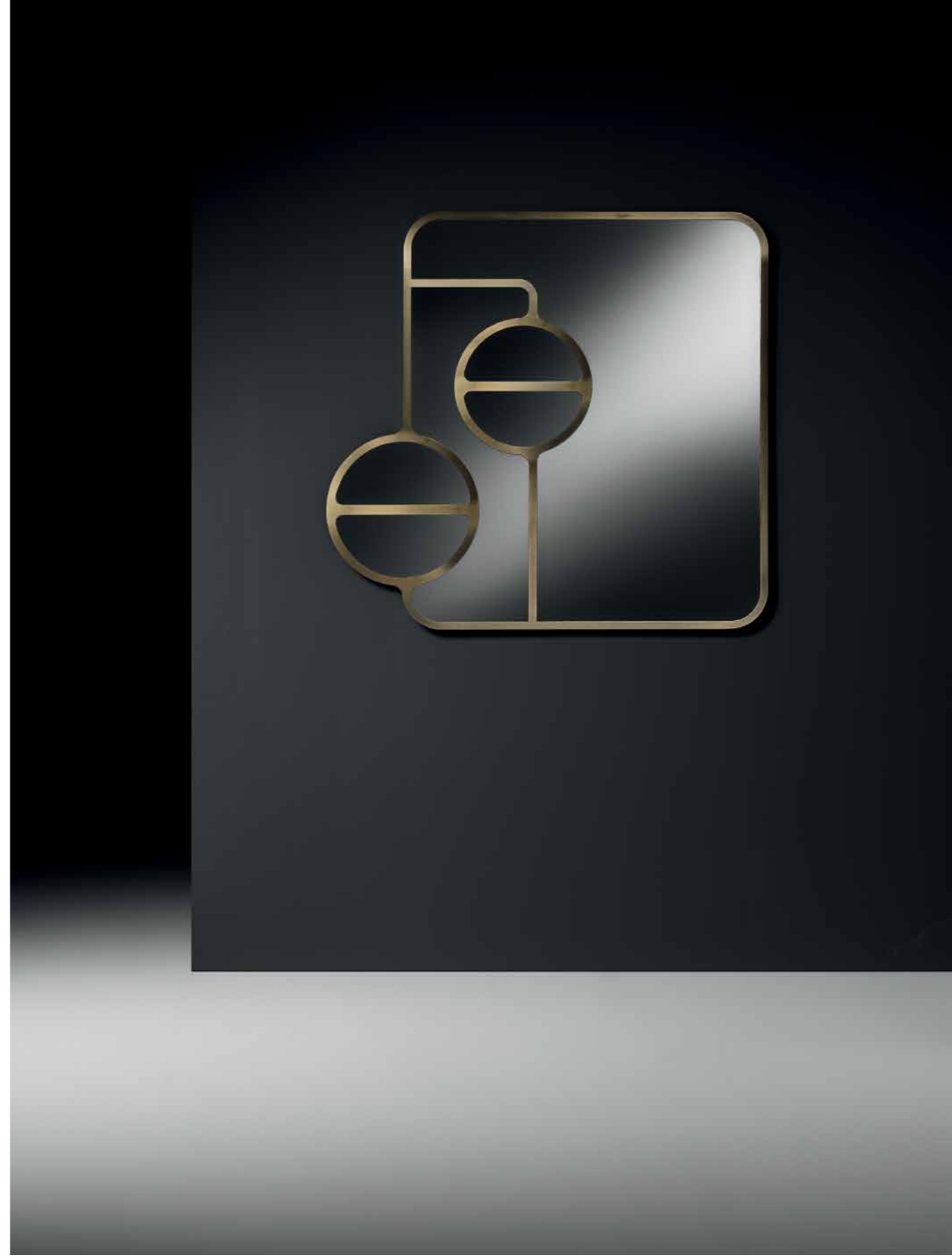

outdoor

Bamboo outdoor
Frisè outdoor



Bamboo outdoor

Pier Luigi Frighetto, 2019



Modular sofa with structure in poplar wood. Padding in high-resilience polyurethane foam in different densities, crossed elastic belt and upholstery in thermo-bonded fibre with stretch jersey. Cushions covered with water-repellent polyester fabric. Water-proof zippers and thread. Removable cover. Side table with structure in varnished metal. Top in solid Iroko wood, treated with protective varnish to lend high resistance to sunlight and weather. Iroko wood may be subject to changes in color.

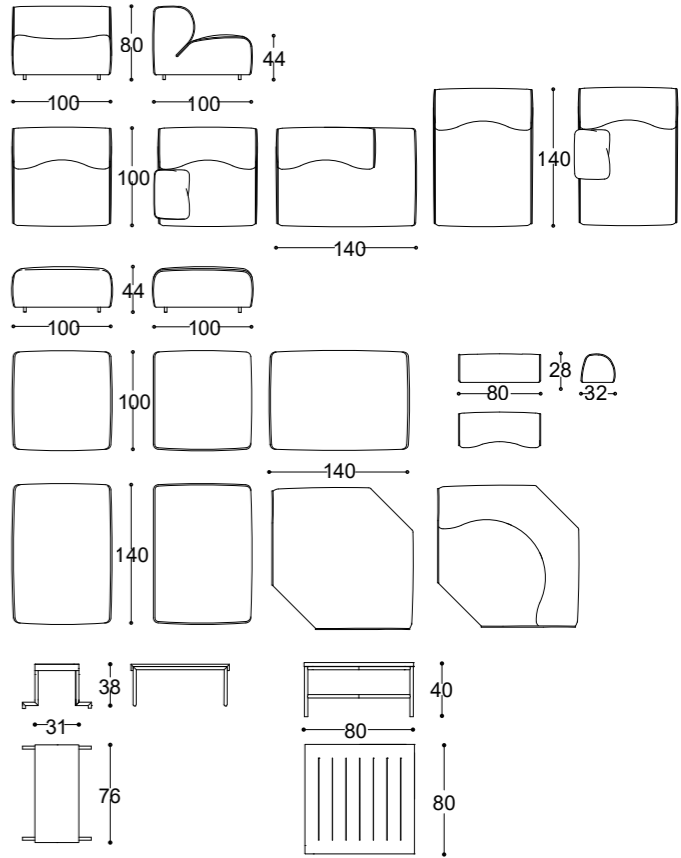

outdoor





Frisè outdoor

Beatriz Sempere, 2019



Armchair and ottoman with structure in wood, made of solid Iroko wood. Treated with protective paint to lend high resistance to sunlight and weather. (Iroko wood may be subject to changes in color). Straps for outdoor use, made of polypropylene, resistant to UV damage. Seat and back cushions in polyurethane foam and polyester fiber. Cushions covered with water-repellent polyester fabric. Water-proof zippers and thread. Removable cover.

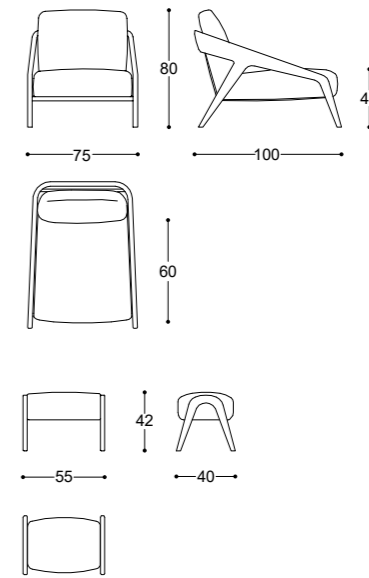

outdoor



Editor and Art Direction / Black Tie
Concept, graphic and artworks / Diamante Beghetto
Interior decoration / Barbara Marsiletti
Photo ambiances / Emanuele Tortora
Still life / Varianti fotografia
Copywriting / Irene Pollini Giolai
Print / GRAFICART Arti Grafiche - April 2018
Special Thanks to / Alpes Inox srl, Studioart Leather Interiors srl

-

Black Tie srl reserves the right to change,
at any time and without prior warning,
the technical specification of any product
illustrated in this catalogue.

-

No part of this publication may be reproduced
in any form or by any means without
prior permission in writing from Black Tie srl
Copyright Black Tie srl. All rights reserved

For further information
please visit our website - www.blacktiesofas.it
Follow us on: Facebook, Instagram, You Tube

Black Tie srl
Via Valchiampo, 54
36050 Montorso Vicentino (VI) Italy
Tel. +39 0444 453009
Fax +39 0444 1833546
blacktie@blacktiesofas.it

