

DAYCOLLECTION

BARZAGHISALOTTI

BARZAGHISALOTTI

Company

La storia di Barzaghi Salotti è la storia della tipica impresa artigiana che viene fondata nel 1953 e che ha saputo mantenere negli anni i propri valori e le proprie tradizioni pur prestando attenzione allo sviluppo del mercato che sta diventando sempre più globale.

Barzaghi Salotti nel 1960 inizia ad ampliare i suoi confini con la distribuzione dei propri prodotti alle regioni limitrofe, spingendosi successivamente a coprire buona parte del territorio nazionale.

I fautori del cambiamento, Luigi Barzaghi e Ugo Caslini, riescono a mantenere una realtà familiare anche successivamente con l'ingresso della terza generazione che nel 2007 prende in mano le redini dell'azienda. I tre soci Alberto Barzaghi, Elena Caslini e Manuela Barzaghi, rivestono da subito differenti responsabilità all'interno dell'azienda, stabilendosi nel settore più consono alle loro inclinazioni.

Barzaghi Salotti was founded in 1953, it is an Italian artisan company that has been able to maintain its values and traditions over the years, paying attention to the development of the market that is becoming more and more global.

In 1960 Barzaghi Salotti begins to expand by distributing its products covering most of the national territory.

Mr. Luigi Barzaghi and Ugo Caslini were the proponents of this change that succeeded in maintaining a family reality also subsequently with the entry of the third generation that in 2007 took over the management of the company.

The three members, Alberto Barzaghi, Elena Caslini and Manuela Barzaghi, have immediately take on different roles and responsibilities within the company, taking into consideration the sector best suited to their inclinations.

Fin dall'inizio l'obiettivo è la "crescita", sia in termini di qualità del prodotto e ricerca dei materiali che di espansione nei territori nazionali ed internazionali.

Il tutto con la collaborazione di designer ed esperti nel settore che partecipano con la loro esperienza ad ottenere un risultato ottimale.

The main objective from the beginning is the "growth" focused on improving quality of the product and looking for the best materials, trying to expand in the national and international territory.

All with expert and designers who participate with their experience to obtain an optimal result.



In un mercato assolutamente senza regole, l'impegno di Barzaghi Salotti rappresenta la massima garanzia del controllo delle materie prime, utilizzando prodotti certificati e di altissima qualità.

Legno massello per le strutture e per le imbottiture utilizza prodotti innovativi, sia nelle prestazioni che nell'affidabilità con qualità controllata e certificata ma soprattutto con un impegno costante per una completa salvaguardia ecoambientale, come per il marchio Olmo utilizzato per le imbottiture in poliuretano.

Il marchio Assopiuma con Etichetta Oro garantisce il controllo del contenuto percentuale di piuma e piumino e del rispetto dell'ideale trattamento igienico-sanitario, come richiesto dalla legislazione italiana (unico Paese Europeo con legislazione in materia).

In an absolutely unregulated market, Barzaghi Salotti's commitment represents the maximum guarantee of the control of raw materials, using certified products of the highest quality. Solid wood for the structures and for the padding uses innovative products, both in performance and reliability with controlled and certified quality but above all with a constant commitment to a complete eco-environmental protection, as for the Olmo brand used for polyurethane padding.

The Assopiuma brand with Gold Label guarantees the control of the percentage content of goose down and down and the respect of the suitable hygienic-sanitary treatment, as required by the Italian legislation (the only European country with legislation on the subject).

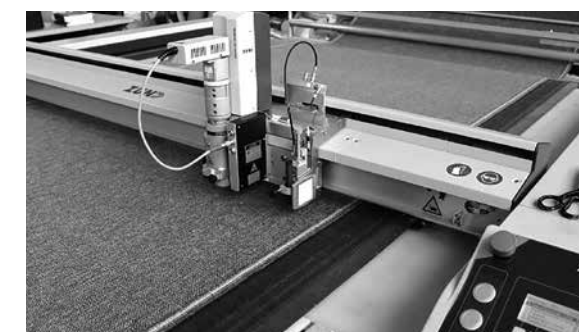



La capacità di plasmarsi in base alle esigenze del cliente, ha dato all'azienda la possibilità di partecipare alla realizzazione di molti progetti importanti in Italia e nel resto del mondo, customizzando il prodotto in relazione al progetto richiesto.

Coniughiamo design, materiali e cura del particolare creando living armoniosi.

The ability of the company to shape, according to customer needs, has given the opportunity to participate on many important projects both in Italy and in the rest of the world, customizing the product in relation with the request of the project.

We blend design, materials and attention to detail, to create harmonious living.



Nel tempo è stata creata un vasta collezione di divani, poltrone, letti e complementi; un graduale processo creativo e produttivo, per arrivare ad un ambiente living completo, che ruota intorno al sistema imbottito, sia esso da indoor o outdoor.

Infatti, accanto alla zona giorno si sta sviluppando anche quella dell'outdoor dove tessuti dedicati e resistenti agli agenti atmosferici, rivestono forme già utilizzate per l'interno; una qualità, che da un lato ne enfatizza la versatilità, dall'altro crea soluzioni di arredo che consentono una maggior fusione tra interno ed esterno.

Grande ricerca è destinata anche alla scelta di tessuti e pellami, cercando sempre di creare una collezione di rilievo che rappresenti in modo unico Barzaghi Salotti.

Over time It was thus created a vast and varied offer of sofas, armchairs, beds and complements: a gradual process of creation of a complete living environment, which revolves around the upholstery system, both for indoor or outdoor.

In fact, alongside the day living has also developed the outdoor where specific fabrics weather resistant are adapted on forms already used for the interior.

A double function that on one hand emphasizes the versatility of products and, on the other, creates design solutions that allow a greater fusion between indoor and outdoor.

Great research is also destined to the choice of fabrics and leathers, always trying to create important collections that represent Barzaghi Salotti in a unique way.



Index

Divani/ Sofas

Bart	Pag.126
Brando Large	Pag.84
Brando	Pag.102
Brando Tailor	Pag.108
Ciak	Pag.114
Duse	Pag.186
In & Out	Pag.158
Join	Pag.178
Lady	Pag.140
Manhattan	Pag.164
Must	Pag.44
Must Over	Pag.34
Portland	Pag.10
Roger	Pag.170
Skip	Pag.24
Time	Pag.148
Young	Pag.54
Young Outdoor	Pag.76

Poltroncine/ Armchairs

Athena	Pag.192
Big	Pag.194
Bang	Pag.196
Easy2	Pag.200
Eel	Pag.202
Ghost	Pag.204
Leonie	Pag.208
Mimi	Pag.212
Mood	Pag.198

Tavolini/ Coffee tables

Round	Pag.124
Square 1	Pag.49
Square 2	Pag.49
Tray	Pag.64

Disegni tecnici/Technical drawings Pag.214

Da sempre l'azienda mira alla ricerca del design per assicurare una collezione attenta alla trasformazione di un mercato globale sempre in espansione, privilegiando inoltre la qualità delle materie prime per garantire la più alta qualità del prodotto finito.

Right from the start the firm aims to research the design to assure a collection constantly monitoring changes in a increasingly more global market, first of all with a choice of the quality of the raw materials to grant the highest quality of the finished product.

PORTLAND

Design CRS Barzaghi Salotti

Dal design morbido ed elegante Portland è un divano dalle proporzioni equilibrate ed un elevato livello di comfort. Le cuciture realizzate ad arte valorizzano ancora di più il design del prodotto.

With a soft and elegant design, Portland is a sofa with balanced proportions and a high level of comfort. The seams made by art enhance the design of the product even more.





SOFA Portland / ARMCHAIR Bang / COFFEE TABLES Round





Questo divano modulare, si impone con la sua ampia scelta di configurazioni, grazie anche all'inserimento di complementi discreti ed eleganti disponibili con le finiture della collezione Barzaghi Salotti.

This modular sofa, imposes itself with its wide choice of configurations, thanks also to the insertion of discreet and elegant accessories available with the finishes of the Barzaghi Salotti collection.







SOFA Portland with bookcase

L'elevata cura sartoriale del rivestimento evidenzia
la capacità artigianale della produzione Barzaghi Salotti.

The high sartorial care of the covering highlights
the craftsmanship of the production Barzaghi Salotti.



SKIP

Design Cesare Ballabio

Skip assume un design personalizzato con la scelta dei piedi o slitte disponibili in diverse finiture. La precisione delle cuciture lungo i bordi del divano mostrano la meticolosa attenzione ai dettagli.

Skip takes on a personalized design with the choice of feet or slides available in different finishes. The precision-perfect stitching around the sofa's edges, illustrates meticulous attention to detail.







SOFA Skip with sledges

Design esclusivo nel segno della leggerezza senza rinunciare al massimo comfort grazie all'imbottitura in piuma d'oca presente nei cuscini seduta, schienale e braccioli.

An exclusive design based on lightness without giving up comfort thanks to feather padding in the seats, backs and armrest cushions.







L'incontro fra essenzialità, ricerca e attenzione al dettaglio.

The meeting between essentiality, research and attention to detail.

MUST OVER

Design CRS Barzaghi Salotti

Una struttura sospesa che accoglie un'ampia serie di elementi di varie dimensioni per una libera interpretazione compositiva.

A minimal suspended frame conceived to be combined a wide range of elements in different size in a free stylistic interpretation.







I basamenti, disponibili in diverse finiture, conferiscono un'immagine leggera e sofisticata.
Con un movimento del cuscino schienale, si possono ottenere due profondità e due altezze.
Disponibile in diverse soluzioni lineari e compositive.

The basements, available in different finishes, give a light and sophisticated image.
With a movement of the back cushion it is possible to obtain double position of comfort with double depth and height. Available linear or modular.



Una scelta che può cambiare l'impatto visivo di un ambiente: da una parte si accentua l'immagine di leggerezza e dall'altra si riconferma la geometria delle forme.

A choice that can change the visual impact of an environment: on one side the image of lightness is accentuated and on the other the geometry of the shapes is reconfirmed.



MUST

Design CRS Barzaghi Salotti

Dal design morbido ed elegante. Con un movimento del cuscino schienale, si possono ottenere due profondità e due altezze. Disponibile in diverse soluzioni lineari e compositive.

Soft design. With a movement of the back cushion it is possible to obtain double position of comfort with double depth and height. Available linear or modular.







Left page: SOFA Must - Right page: COFFEE TABLES Square 1 - Square 2

Da non considerare solamente come un elemento di servizio, questo tavolo dalle linee essenziali e con la massima cura per i dettagli è sviluppato in tre diverse dimensioni. Square 1 si distingue per le caratteristiche colonnine che donano ulteriore geometria al prodotto. Square 2, disponibile in due diverse misure, lascia invece spazio ad un'immagine di leggerezza.

It's not to consider it only as a service element for sofas, this table with basic lines and the utmost care for details is developed in three different sizes. Square 1 is distinguished by the characteristic columns that give further geometry to the product. Square 2, available in different sizes, leaves room for an image of lightness.



Square 1



Square 2





Con un semplice movimento del cuscino schienale, si possono ottenere due profondità e due altezze che soddisfano il momento della conversazione o quello del totale relax.

Soft design. With a simple movement of the back cushion, you can get two depths and two heights that satisfy the moment of conversation or that of total relax.



YOUNG

Design CRS Barzaghi Salotti

L'eleganza e il prestigio di un divano che si sviluppa con armoniche aggregazioni.

The elegance and prestige of a sofa that is constructed by harmoniously combining various elements.





SOFA Young





Elementi di diverse dimensioni con struttura monoscocca collegabili tra loro utilizzando uno speciale innesto che permette di combinare molteplici composizioni dando inoltre la possibilità di scomporre gli schienali e braccioli dalle rispettive basi per cambiare l'idea compositiva in qualsiasi momento.

Elements with different shapes and sizes with one-piece frame connectable with each other using an exclusive connector that allows you to combine different compositions. In this way the backrest and the arms can be removed from the bases to change composition as you want.







Tutti gli elementi compositivi, compresi i braccioli e gli schienali sono rifiniti con un trapuntino di piuma d'oca che evidenzia il comfort e un aspetto estetico unico e molto fresco accentuato anche dalla particolare cucitura a piattina o in pelle dalla cucitura denominata a "taglio a vivo". I cuscini schienale sono utilizzabili in assoluta libertà spaziando dal cuscino più grande in piuma al cuscino poggiatesta, o ancora dall'utilizzo dei cuscini decorativi della collezione Barzaghi Salotti.

All this elements, are covered with a feather quilt that shows the comfort and a new and unique look thanks also to the particular stitching that are available with raw-edged leather upholstery.

You can freely choose between big feather back cushion or pillows in different sizes in the Barzaghi Salotti collection.





È un oggetto versatile che può essere usato come base per molte situazioni domestiche, con il suo design basato su un piano in legno appoggiato su un supporto di metallo solido disponibile in diverse finiture e studiato per l'accostamento ad ogni divano occupando il minor spazio possibile.

It is able to be adapted to many domestic environments with its design based on a square tray resting on a solid metal support available in different finishes and designed for the combination with each sofa without losing space.



Tray



Forte personalità e massima libertà compositiva anche per le basi con relativi schienali trapezoidali zavorrati, posizionabili liberamente.

A strong personality and utmost freedom of arrangement for the bases and trapezoidal heavy backs that can be positioned at will.







La molteplicità degli elementi permette di collocare Young Free in qualsiasi ambiente domestico, garantendo il massimo comfort.

The multiplicity of the elements makes it possible to place Young Free in any domestic environment, giving maximum comfort.





YOUNG OUTDOOR

Design CRS Barzaghi Salotti

Elementi di diverse dimensioni con struttura monoscocca idrorepellente, collegabili tra loro utilizzando uno speciale innesto che permette di combinare molteplici composizioni dando inoltre la possibilità di scomporre gli schienali e braccioli dalle basi per cambiare l'idea compositiva in qualsiasi momento.

Elements with different shapes and sizes with one-piece frame, waterproof, connectable with each other using an exclusive connector that allows you to combine different compositions. In this way the backrest and the arms can be removed from the bases to change composition as you want.









Tutti gli elementi compositivi, compresi i braccioli e gli schienali sono rifiniti con materiali per uso esterno resistenti agli agenti atmosferici e fodera di ricopertura in tessuto idrorepellente. Rivestimento in tessuto per esterni, interamente sfoderabile. I cuscini schienale sono utilizzabili in assoluta libertà spaziando dal cuscino più grande al cuscino poggiatesta, imbottiti con fibre per uso esterno.

All this elements, are covered with fiber for outdoor and a waterproof fabric. Upholstery with outdoor fabrics, fully removable. You can freely choose between big feather back cushion and another back pillow padded with outdoor fiber.



BRANDO LARGE

Design CRS Barzaghi Salotti

Una totale libertà compositiva, una struttura pensata per accogliere un'ampia serie di elementi e accessori disponibili in legno e ferro laccato con mensole. Brando Large è una proposta di Barzaghi Salotti per il comfort dell'area living contemporanea.

Total compositional freedom, a frame conceived to be combined with a wide range of elements and accessories available in wood and in lacquered iron, fitted with shelves. Brando Large is a new proposal by Barzaghi Salotti for total comfort in the contemporary living area.









Brando Large sorprende per le mille possibilità di combinazioni che offre, rendendolo un imbottito dalla grande versatilità e adattabilità.

Brando Large all astonishes for the many combination that make it hugely adaptable and versatile, able to show its endless faces with elegance and refinement.







La scelta del bracciolo tradizionale, può inoltre essere sostituita dall'utilizzo di elementi e accessori, dando vita ad emozioni diverse. L'impatto molto piacevole si alterna all'utilità di questi complementi che offrono uno spazio importante alle necessità quotidiane.

The choice of the traditional armrest can also be replaced by the use of elements and accessories, giving rise to different emotions. The very pleasant impact alternates with the usefulness of these complements that offer an important space for everyday needs.







È disponibile nella variante componibile, con cui costruire soluzioni spaziali e composizioni inedite. Brando Large si compone di elementi centrali e terminali: forme dinamiche con cui costruire diverse soluzioni dando vita a spazi più coinvolgenti e aprendo la strada a giochi di combinazioni.

Is available in the modular version to build new spatial solutions and original compositions. Brando Large consists of central and terminal elements: dynamic shapes which come together different solutions to make even more alluring spaces and opening to new settings and combinations.



BRANDO

Design CRS Barzaghi Salotti

Una struttura sospesa minimale pensata per conferire un aspetto di eleganza e leggerezza. Brando è da definire come il divano dall'eleganza senza tempo ma completamente in linea con i trend del momento.

A minimal suspended frame conceived to give an elegant and lighter appearance essentiality. Brando is defined the timeless sofa but completely in the mood with the current trend.







BRANDO TAILOR

Design Cesare Ballabio

Brando Tailor è un prodotto che sottolinea la sartorialità e l'attenzione al dettaglio, accentuato dallo schienale suddiviso in tre parti da inserti in tinta o con colore in contrasto. I cuscini realizzati anche nella versione senza inserti, dialogano con il resto del design in modo armonico.

Brando Tailor marked the tailoring and the attention to the detail, that could be emphatic with the back cushions with the stitching in different or same colour. The backs are also made in the simple version, without subdivision and create a dialogue with the rest of the design in a harmonious way.





SOFA Brando Tailor / COFFEE TABLE Round



CIAK

Design CRS Barzaghi Salotti

Eleganti proporzioni caratterizzate da uno stile armonico e contemporaneo. Gli schienali destrutturati e utilizzati in piena libertà, offrono a questo prodotto un comfort ed una seduta più informali.

Elegant proportions characterized by a harmonious and contemporary style. The deconstructed and freely used backrests offer this product more informal comfort and seating.







SOFA Ciak



Grazie alla forma squadrata della scocca e a quella morbida dei cuscini, Ciak acquista comfort, slancio e leggerezza.

Thanks to the square design of the structure and the soft cushions, Ciak gains in height, streamling and lightness.

Il piede in metallo realizzabile in diverse finiture,
dona un dettaglio sofisticato a questo prodotto di grande
attualità.

The metal feet, available in different finishes,
gives a sophisticated detail to this great trendy product.



Il carattere versatile di questo prodotto, gli permette di essere accostato ai più tradizionali o attuali design del living contemporaneo.

The versatil character easily merges with both the most traditional and modern design in the contemporary living.



5 diametri, disponibili in 5 colori e per la misura 88 e 120 possono essere scelti i top in marmo in 4 finiture.

5 diameters available in 5 colours and for the 88 and 120 measures the top can be chosen among different marble types.



Marmo Calacatta
Calacatta marble



Marmo di Carrara
Carrara marble

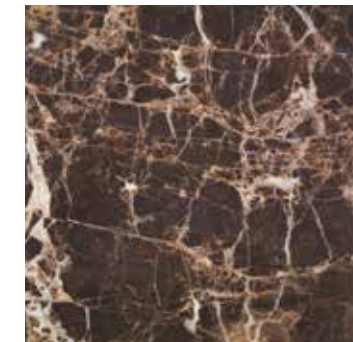

Marmo nero Emperador
Emperador marble



Marmo grafite grey
Grafite grey marble

BART

Design CRS Barzaghi Salotti

Divano che assicura tre punti fondamentali: comfort, grazie all'utilizzo della piuma supportata da materiali di nuova generazione-design, grazie alla rivisitazione di una linea sempre presente nel tempo-eleganza, garantita dalla presenza di numerosi cuscini che gli conferiscono un aspetto ricercato dal punto di vista stilistico.

Sofa that guarantees three basic points: comfort, thanks to the use of the feather supported by new generation materials - design, thanks to the restyling of a line that is always presents over time - elegance, guaranteed by the presence of many cushions that give it a highly refined and stylish product. Available linear or modular.













SOFA Bart

I cuscini destrutturati in piuma gli conferiscono un'eleganza senza tempo e trasmettono immediatamente un comfort assoluto.

The unstructured down-filled cushions give it a timeless elegance and immediately convey absolute comfort.

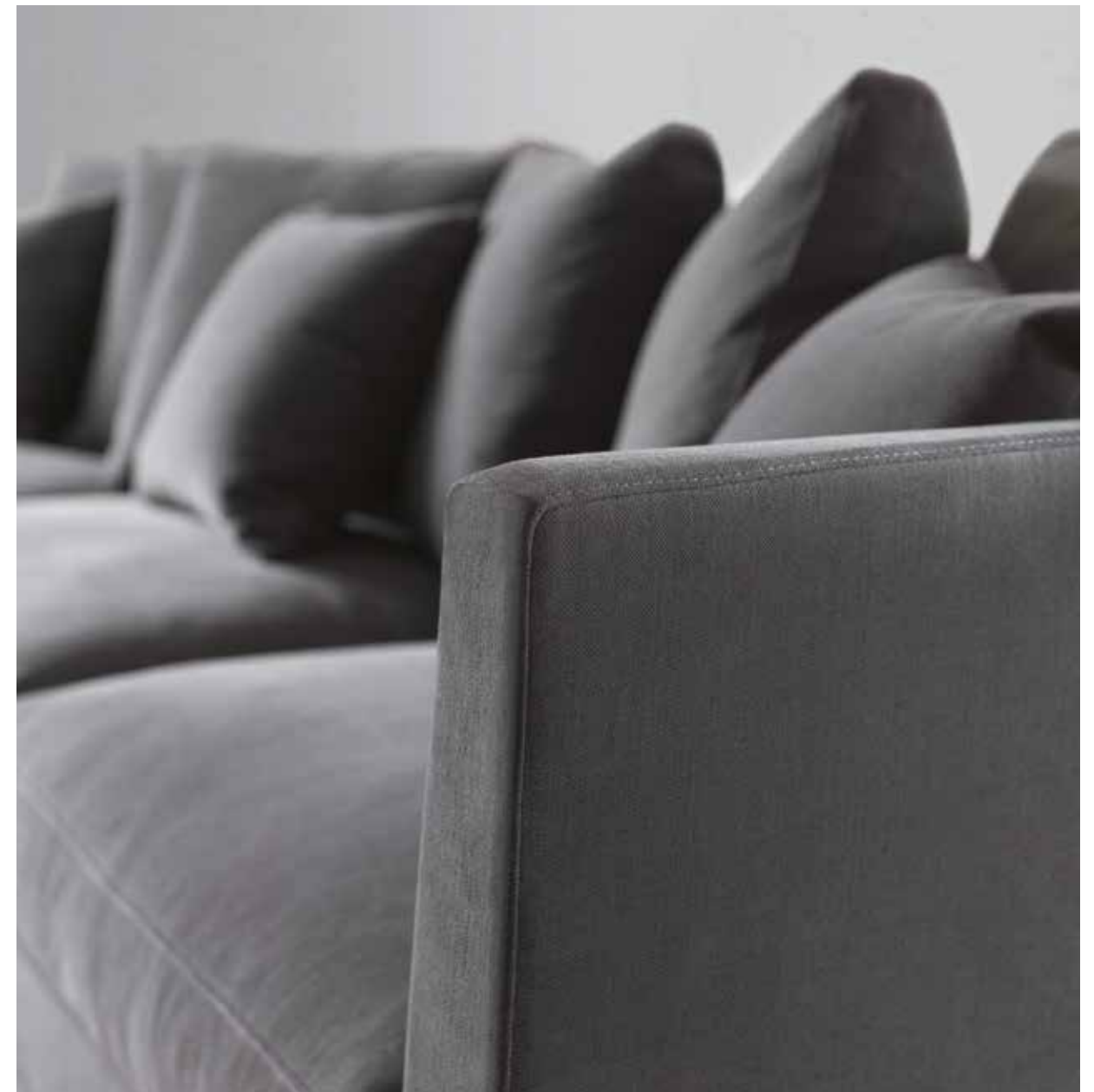

Realizzato sia nella versione lineare che in quella compositiva, Bart si propone in una moltitudine di soluzioni e ambienti, assumendo per magia un aspetto romantico o metropolitano in funzione del rivestimento utilizzato.

Available linear or modular, Bart proposes itself in a multitude of solutions and environments, assuming by magic a romantic or metropolitan aspect depending on the covering used.



LADY

Design CRS Barzaghi Salotti

Un prodotto che conquista immediatamente l'occhio grazie al design ricercato e senza tempo con una particolare attenzione al dettaglio di cuciture e basamento.

A product that immediately catches the eye thanks to the sophisticated and timeless design with a particular attention to detail of stitching and base.





Left page: SOFA Lady - Right page: SOFA Lady / COFFEE TABLE Square 2 / ARMCHAIR Eel / POUFF Soft pouf



SOFA Lady / POUFF Soft pouf

Dall'aspetto morbido ed elegante, sottolineato dal dettaglio della cucitura a piattina e dall'inserimento della piuma anche nella parte strutturale.

Soft design with a trendy appearance thanks to the stitching highlighted and the duck feathers also on the structure.

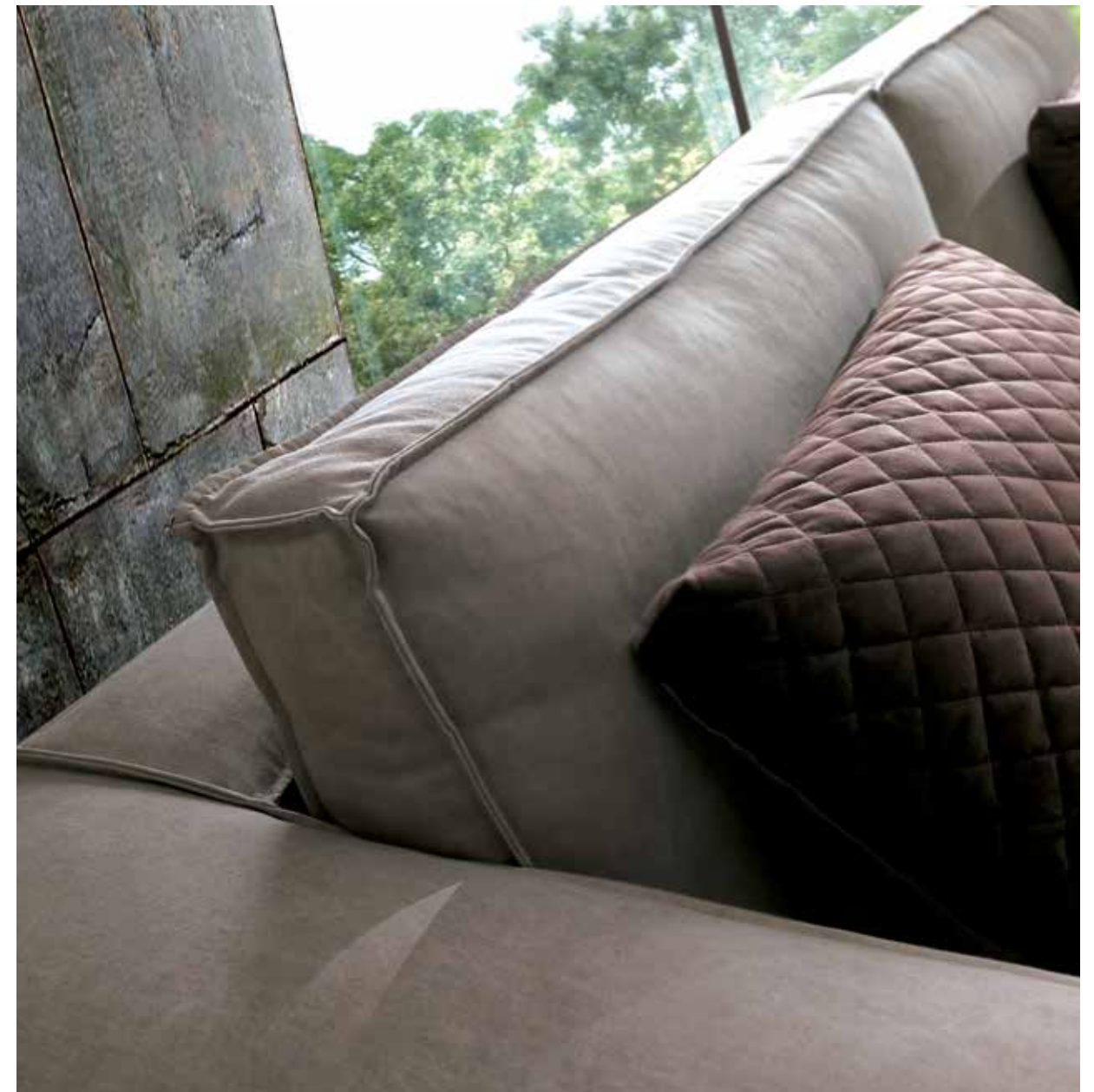

Disponibile con piedi o con basamento continuativo
in metallo nelle diverse finiture.

Available with a simple feet or a total base in metal
in different finishes.



TIME

Design CRS Barzaghi Salotti

Divano raffinato con una linea senza tempo. L'eleganza e il prestigio di un divano che si sviluppa in molteplici composizioni.

An elegant sofa with a timeless design. The elegance and prestige of a sofa that is constructed by different compositions.







Modernità, fascino, semplicità: tre caratteristiche che fanno di Time un divano molto apprezzato.

Modernity, charm, simplicity: three features that make Time a highly appreciated sofa.



Il piede scultoreo, tradizionale e hi-tech al tempo stesso, delinea ulteriormente l'eleganza di questo modello.

The sculptural foot, classic and hi-tech at the same time, distinguish another time, the elegance of this model.





IN&OUT

Design Cesare Ballabio

Una proposta che coniuga l'aspetto estetico e il comfort assoluto. Con un semplice movimento ogni seduta diventa un ampio spazio per rilassarsi ai massimi livelli.

A model that combines a trendy appearance with absolute comfort. With a simple movement each seat becomes a large space to relax at the highest level.





SOFA In 8 Out

È nei dettagli che va ricercata la peculiarità del progetto e con In8Out lo stesso elemento può regalare diversi scenari in un unico ambiente.

It's in the details that the peculiarity of the project must be sought and with In8Out the same element can give different scenarios in a single environment.





SOFA In 8 Out



MANHATTAN

Design CRS Barzaghi Salotti

Uno stile metropolitano e un design esclusivo per un divano ispirato al passato e rivisitato in chiave moderna.

A metropolitan style and an exclusive design for a sofa inspired by the past but revisited in a modern way.







SOFA Manhattan

Eleganti proporzioni e una comodità senza confronti grazie alle morbide imbottiture in piuma, sia nella seduta che nello schienale.

Elegant proportions and in incorporable comfort thanks to the feather-filled seat and backrest cushions.

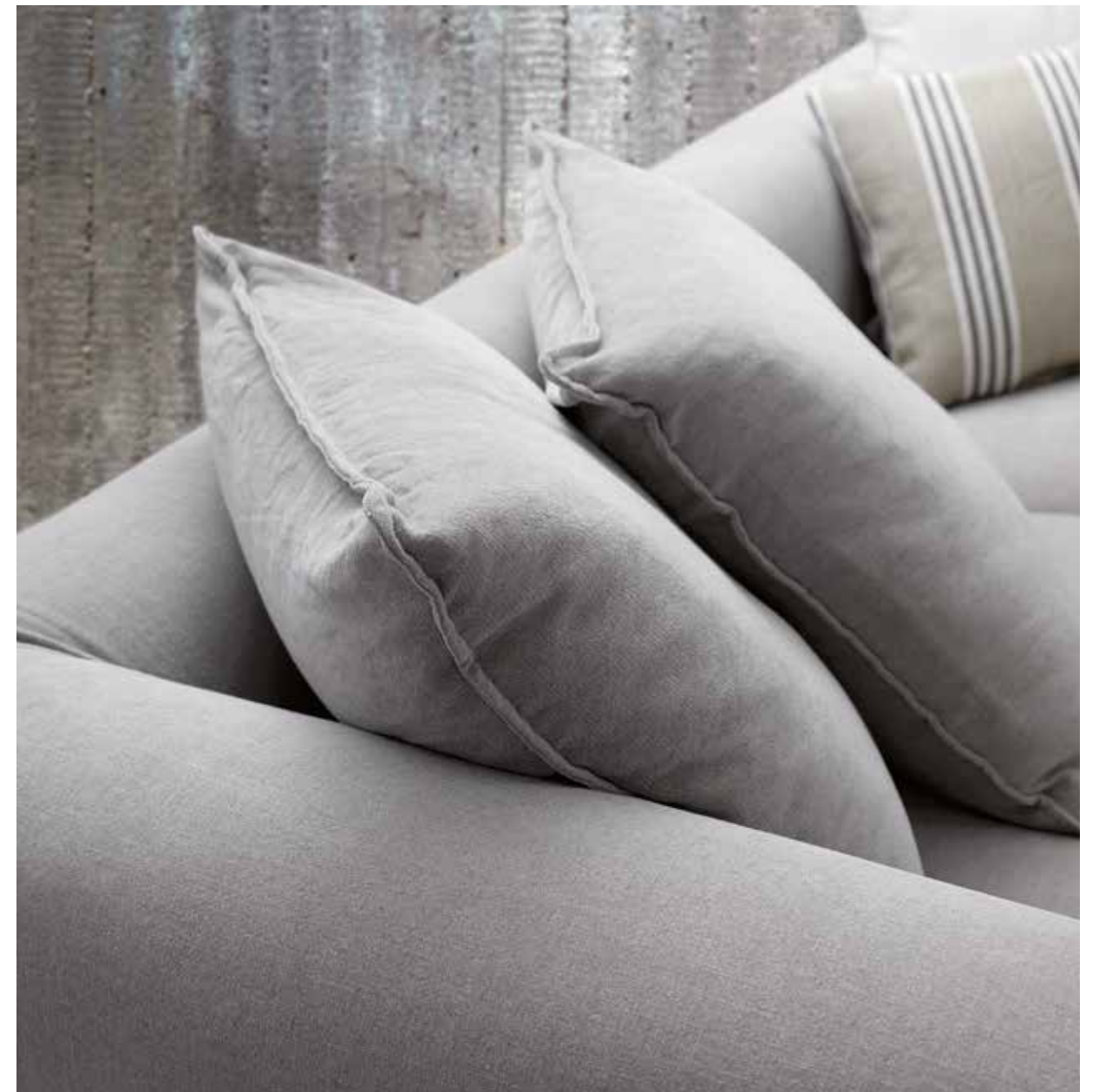

ROGER

Design CRS Barzaghi Salotti

Un'immagine contemporanea dell'imbottito che sfocia nella massima elasticità compositiva. Dalle linee rigorose e dal comfort assoluto Roger conserva un design senza tempo.

A contemporary image of upholstered furniture which flows in the utmost flexible composition. From the strict lines and absolutely comfort Roger conserves a timeless design.





SOFA Roger / COFFEE TABLE Round



Molto versatile grazie alla presenza di elementi che permettono di cambiare la composizione in base all'esigenza del momento.

Very versatile, thanks to the presence of elements that allow you to change the composition based on the need of the moment.





JOIN

Design CRS Barzaghi Salotti

Raffinato e confortevole, Join si contraddistingue per le originali proporzioni e il dettaglio di braccioli, schienale che ne fanno un divano di particolare eleganza.

Elegant and comfortable, the distinctive features of Join are the original proportions and details of the armrests, back which make it especially elegant.







SOFA Join / COFFEE TABLE Round

Modernità, fascino, semplicità: tre qualità che fanno di Join un divano molto apprezzato.

Modernity, charm, simplicity: three qualities that make Join a highly appreciated sofa.





DUSE

Design CRS Barzaghi Salotti

Linea classica impreziosita a richiesta dalla cucitura a cordoncino in tinta o a contrasto.
Eleganza ma soprattutto quel gusto senza tempo che supera le mode del momento.

Classical design, made precious, on request, by the contrasting or same colour overstich detail.
Elegance but above all an ageless taste that survives passing fads.





Vasta anche la gamma di poltroncine per rendere qualunque ambiente più decorato, accogliente e funzionale. Utili anche per avere comode sedute supplementari utilizzando meno spazio.

A vaste range of armchairs to make any room decorated, welcoming and functional.

Also useful to have extra comfortable seats with less space.



ATHENA

Design Cesare Ballabio

Armoniose geometrie e volumi equilibrati per una poltrona dal design innovativo. Particolare attenzione al dettaglio che ne valorizzano la sartorialità.

Harmonious geometric lines and balanced volumes for an innovative design armchair. Particular attention to the detail that enhances the tailoring.





BIG

Design CRS Barzaghi Salotti

La poltrona Big, prevista con il basamento girevole, presenta una struttura leggera ed un ampio e alto schienale molto avvolgente.

The swivel Big armchair, with its swivel basement, has a light and sinuos structure and a tall and very encircled backrest.





BANG

Design CRS Barzaghi Salotti

La poltroncina Bang si caratterizza per le proporzioni impeccabili, bilanciando la curvatura della struttura, con la linearità della base, disponibile sia con basamento girevole a raggiera che con gambe stilizzate in diverse finiture, assumendo un aspetto camaleontico per una collocazione in molteplici ambienti.

The Bang armchair is characterized by impeccable proportions, balancing the curve of backrest, with the linearity of the base, available both with the swivel base and stylized legs in different finishes. It takes a chameleon-like appearance for placement in multiple environments.





MOOD

Design CRS Barzaghi Salotti

Dalle dimensioni molto compatte e dalla forma molto avvolgente, Mood trova la sua collocazione in piccoli spazi nel living e in altri ambienti domestici.

With very compact dimensions and a very enveloping shape, Mood finds its place in small spaces in the living and in other domestic environments.



EASY2

Design CRS Barzaghi Salotti

Easy2 è una poltrona dalle linee asciutte ed essenziali che tuttavia esprime un'eleganza raffinata grazie anche al dettaglio dei basamenti. Trova spazio sia nel living domestico che negli ambienti lavorativi.

Easy2 is an armchair with essential lines that nevertheless expresses a refined elegance, also thanks to the basements detail. It finds his space inside the home and in the offices.





EEL

Design CRS Barzaghi Salotti

Eel è una poltrona dallo stile classico-contemporaneo, contraddistinta da un'estetica al di là del tempo e delle mode.

It is an armchair with classic-contemporary lines, Eel's timeless aesthetic transcends the bounds of changing seasons and fading fashions.



GHOST

Design CRS Barzaghi Salotti

Dimensioni compatte e linea accogliente per stare comodamente rilassati e in totale benessere, dotata inoltre di base girevole, a scelta. Il dettaglio della cucitura in rilievo dona originalità ed elegante freschezza.

Compact dimensions and inviting design for sitting and relaxing in total well-being, with the choice of a swivel base. The stitching detail gives original and fresh elegance design.







LEONIE

Design CRS Barzaghi Salotti

Linee sinuose e comfort avvolgente per la poltrona Leonie, dotata inoltre di base girevole che conferisce ulteriore relax. Importante e strutturata, Leonie è un accogliente approdo dello spazio domestico.

Curvy lines and cosy comfort for the Leonie armchair, with a comfortable swivel base. Handsome and well structured, Leonie is a welcoming haven inside the home.





MIMÌ

Design CRS Barzaghi Salotti

Uno stile senza tempo per la raffinata poltroncina pensata per una casa elegante.

A timeless style for a refined armchair designed for an elegant home.





BART Design CRS Barzaghi Salotti

STRUTTURA. In legno massello rivestito con poliuretano espanso a quote differenziate ad alta resistenza. Molleggio garantito da cinghie elastiche ad alto componente di caucciù.

RIVESTIMENTO FINALE. Tessuto, completamente sfoderabile. Pelle (cuscinature sfoderabili).

CUSCINI SCHIENALE. In piuma d'oca vergine lavata e sterilizzata, canalizzata e rivestita in cotone 100%.

CUSCINI SEDUTA. Cuscini seduta in piuma d'oca canalizzata con inserto portante in poliuretano espanso ad alta resilienza.

PIEDI. Metallo - acciaio inossidabile h. mm 35 Finiture: cromato - brunito. Legno h. mm 35 Finiture: noce - wengè.

STRUCTURE. In solid wood covered with high resilience, variable-density polyurethane foam and a breathable heat-bonded quilted fiber casing laminated to a white cotton fabric. Suspension provided by high-rubber-content elastic webbing.

COVER. Fabric, completely removable. Leather, cushions removable.

BACKREST CUSHIONS. Filled with washed and sterilized channeled goose down.

SEAT CUSHION. Made with channeled goose down padding with structural support insert in polyurethane foam.

FEET. Metal - stainless steel h. mm 35. Finishes: chromed - burnished wood h. mm 35. Finishes: walnut - wengè.

ELEMENTI SINGOLI / ELEMENTS

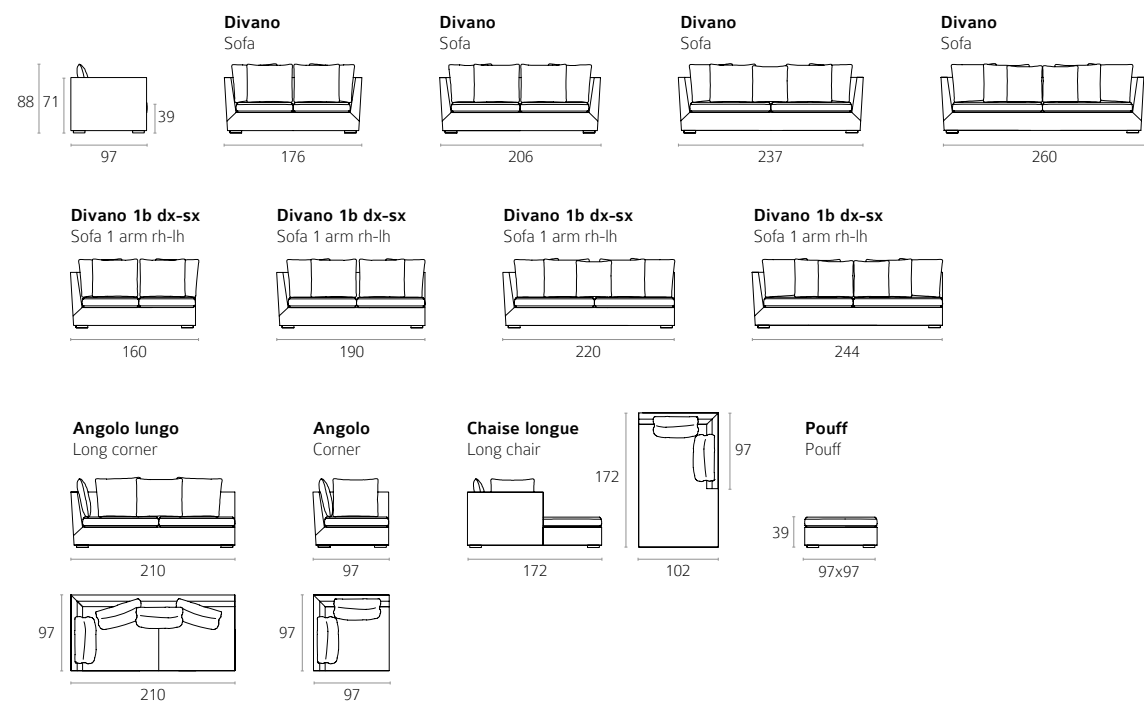

FINITURE PIEDE / FEET FINISHES

LEGNO / WOOD



Noce
Walnut

Wengè
Wengè

METALLO / METAL

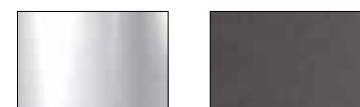

Cromato
Chromed

Brunito opaco
Matt burnished



BRANDO Design CRS Barzaghi Salotti

STRUTTURA. In legno massello rivestito con poliuretano espanso a quote differenziate ad alta resilienza e ricoperto da fibra termolegata e traspirante accoppiata con tela di cotone bianca. Molleggio garantito da cinghie elastiche ad alto componente di caucciù.

RIVESTIMENTO FINALE. Tessuto, completamente sfoderabile. Pelle, cuscini seduta e schienale sfoderabili.

CUSCINI SCHIENALE. In piuma d'oca vergine canalizzata (certificata Assopiuma, Etichetta Oro) con inserto in poliuretano espanso ad alta resilienza.

CUSCINI SEDUTA. In piuma d'oca canalizzata (Certificata Assopiuma, Etichetta Oro) con inserto in poliuretano espanso ad alta resilienza.

PIEDI. Alluminio H. mm 160 - finiture disponibili: cromato - brunito opaco - satinato.

STRUCTURE. In solid wood covered with high resilience, variable-density polyurethane foam and a breathable heat-bonded quilted fiber casing laminated to a white cotton fabric. Suspension provided by high-rubber-content elastic webbing.

COVER. Removable fabric. Leather, only cushions removable.

BACKREST CUSHIONS. Are made with channeled goose down (Certified Assopiuma, Gold Label) with structural support insert in polyurethane foam.

SEAT CUSHION. Are made with channeled goose down padding (Certified Assopiuma, Gold Label) with a structural support insert in polyurethane foam.

FEET. Aluminium H. mm 160 - Finishes: chromed - matt burnished - satine.

ELEMENTI SINGOLI / ELEMENTS

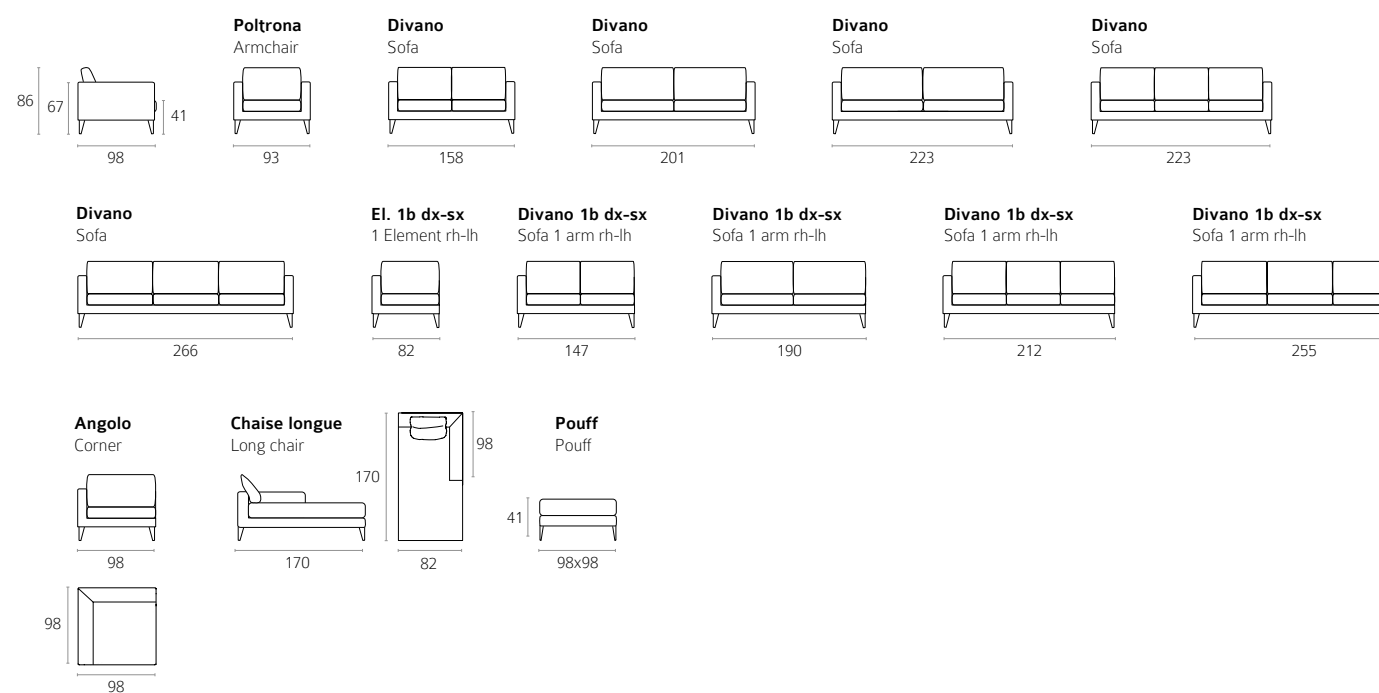

FINITURE PIEDE / FEET FINISHES

METALLO / METAL



Cromato
Chromed

Satinato
Satinated

Brunito opaco
Matt burnished



BRANDO LARGE Design CRS Barzaghi Salotti

STRUTTURA. In legno massello rivestito con poliuretano espanso a quote differenziate ad alta resistenza e ricoperto da fibra termolegata e traspirante accoppiata con tela di cotone bianca. Molleggio garantito da cinghie elastiche ad alto componente di caucciù.

RIVESTIMENTO FINALE. Tessuto, completamente sfoderabile. Pelle, cuscini seduta e schienale sfoderabili.

CUSCINI SCHIENALE. In piuma d'oca vergine canalizzata - Cuscino schienale supplementare in piuma d'oca vergine canalizzata.

CUSCINI SEDUTA. In poliuretano espanso ad altissima resilienza a quote differenziate con PF 40/M e OLMOSOFF 35, rivestito con ovatta gr. 200 accoppiata a vellutino. Rivestimento in cotone 100% sfoderabile.

PIEDI. In pvc nero antiscivolo, H. mm 20.

STRUCTURE. In solid wood covered with high resilience, variable-density polyurethane foam and a breathable heat-bonded quilted fiber casing laminated to a white cotton fabric. Suspension provided by high-rubber-content elastic webbing.

COVER. Completely removable fabric. Leather, only cushions removable.

BACKREST CUSHIONS. Made with channeled goose down padding - extra backrest cushions with channeled goose down padding.

SEAT CUSHION. In polyurethane foam with high resilience PF 40/M e OLMOSOFF 35, upholstered with fiber gr. 200 coupled with velvet and covered with cotton 100%.

FEET. In black pvc, mm. 20 high.

ELEMENTI SINGOLI / ELEMENTS

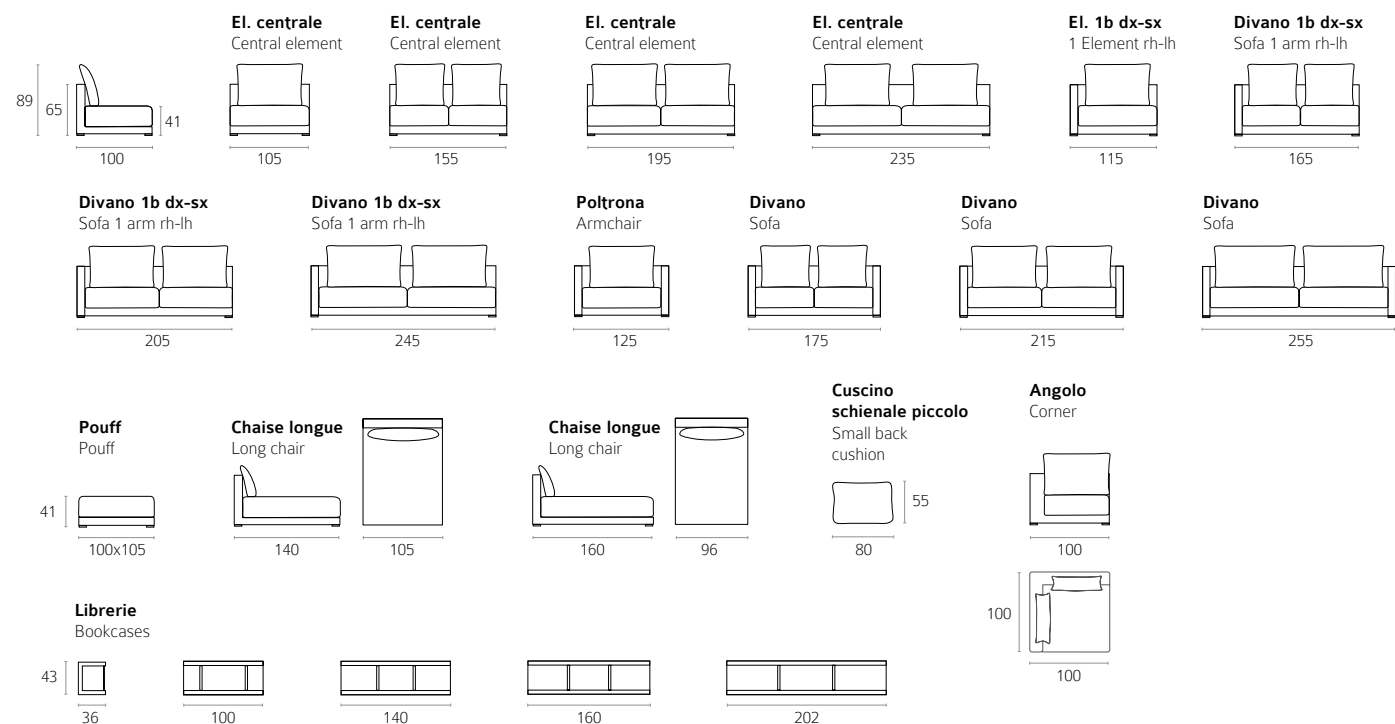

FINITURE LIBRERIA / BOOKCASES FINISHES

LEGNO / WOOD

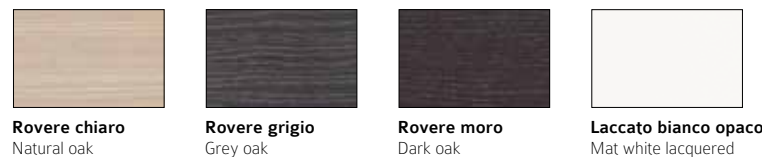

METALLO / METAL

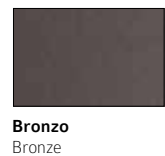

BRANDO TAILOR Design CRS Barzaghi Salotti

STRUTTURA. In legno massello rivestito con poliuretano espanso a quote differenziate ad alta resilienza e ricoperto da fibra termolegata e traspirante accoppiata con tela di cotone bianca. Molleggio garantito da cinghie elastiche ad alto componente di caucciù.

RIVESTIMENTO FINALE. Tessuto, completamente sfoderabile. Pelle, cuscini seduta e schienale sfoderabili.

CUSCINI SCHIENALE. In piuma d'oca vergine canalizzata. Disponibili con o senza profilo a contrasto.

CUSCINI SEDUTA. In poliuretano espanso ad altissima resilienza a quote differenziate con PF 40/M e OLMOSOFF 35, rivestito con ovatta gr. 200 accoppiata a vellutino. Rivestimento in cotone 100% sfoderabile.

PIEDI. Alluminio H. mm 90 - finiture disponibili: brunito.

STRUCTURE. In solid wood covered with high resilience, variable-density polyurethane foam and a breathable heat-bonded quilted fiber casing laminated to a white cotton fabric. Suspension provided by high-rubber-content elastic webbing.

COVER. Completely removable fabric. Leather, only cushions removable.

BACKREST CUSHIONS. Made with channeled goose down padding. Available with or without tail stitching.

SEAT CUSHION. In polyurethane foam with high resilience PF 40/M e OLMOSOFF 35, upholstered with fiber gr. 200 coupled with velvet and covered with cotton 100%.

FEET. Alluminium H. mm 90 - Finishes: burnished.

ELEMENTI SINGOLI / ELEMENTS

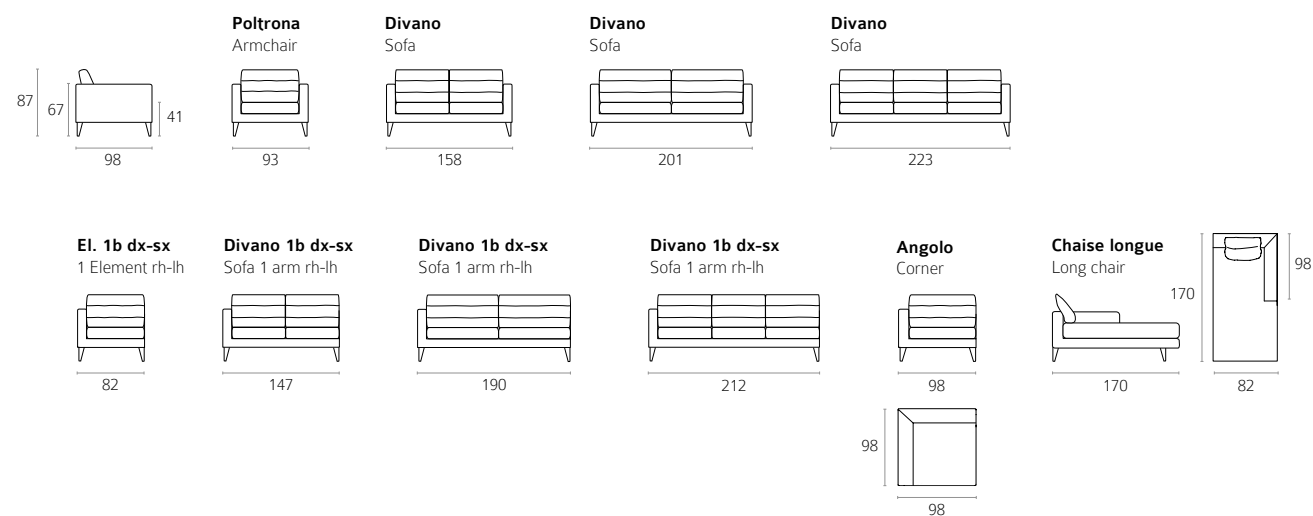

FINITURE PIEDE / FEET FINISHES

METALLO / METAL

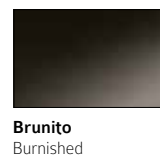



CIAK Design CRS Barzaghi Salotti

STRUTTURA. In legno massello rivestito con poliuretano espanso a quote differenziate ad alta resistenza e ricoperto da fibra termolegata e traspirante accoppiata con tela di cotone bianca. Molleggio garantito da cinghie elastiche ad alto componente di caucciù.

RIVESTIMENTO FINALE. Tessuto, completamente sfoderabile. Pelle, cuscini seduta e schienale sfoderabili.

CUSCINI SCHIENALE. In piuma d'oca vergine canalizzata.

CUSCINI SEDUTA. In poliuretano espanso ad alta resilienza.

PIEDI. Metallo - alluminio - H. mm 180 - finiture disponibili: cromato, brunito opaco, satinato.

STRUCTURE. In solid wood covered with high resilience, variable-density polyurethane foam and a breathable heat-bonded quilted fiber casing laminated to a white cotton fabric. Suspension provided by high-rubber-content elastic webbing.

COVER. Removable fabric. Leather, only cushions removable.

BACKREST CUSHIONS. In channeled goose down.

SEAT CUSHION. In polyurethane foam with high resilience and dacron.

FEET. Metal - aluminium - H. mm 180 - Finishes: chromed - matt burnished - satined.

ELEMENTI SINGOLI / ELEMENTS

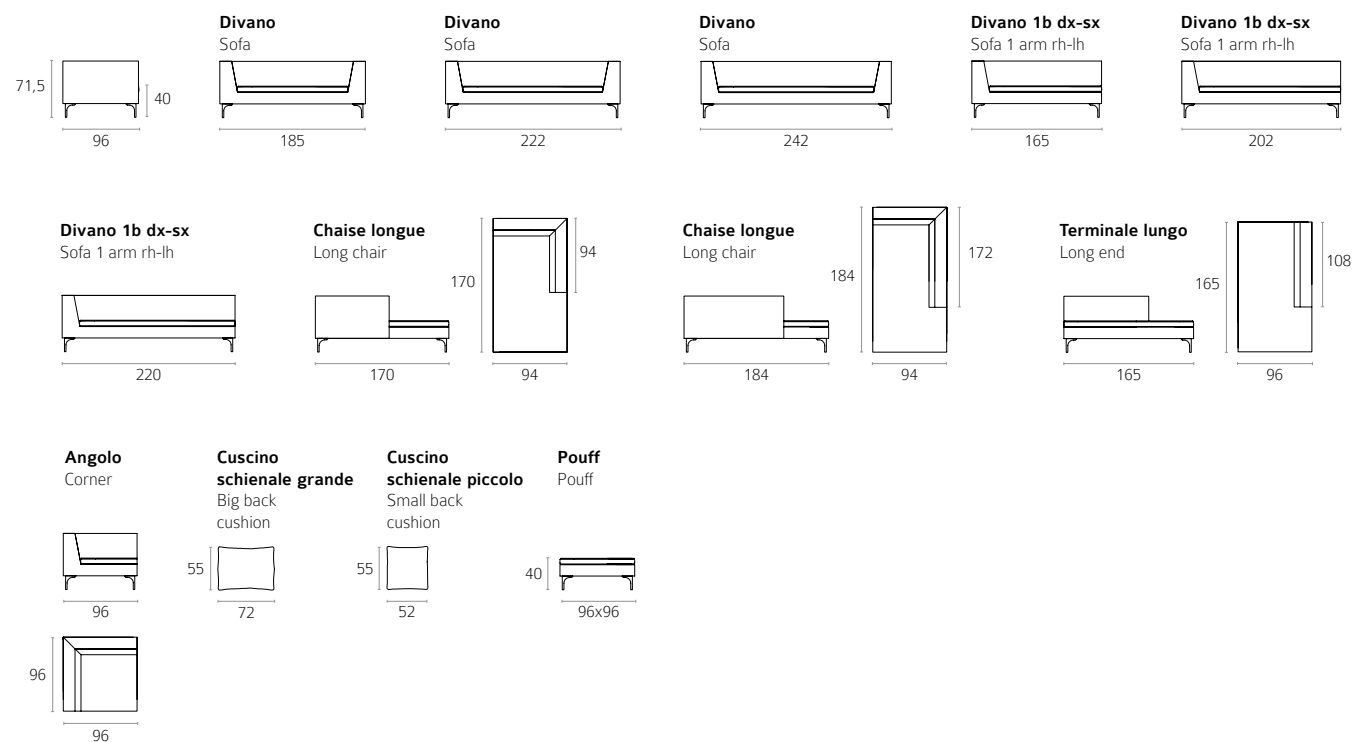

FINITURE PIEDE / FEET FINISHES

METALLO / METAL



Cromato Chromed
Satinato Satined
Brunito opaco Matt burnished



DUSE Design CRS Barzaghi Salotti

STRUTTURA. In legno massello rivestito con poliuretano espanso a quote differenziate ad alta resistenza e ricoperto da fibra termolegata e traspirante accoppiata con tela di cotone bianca. Molleggio garantito da cinghie elastiche ad alto componente di caucciù.

RIVESTIMENTO FINALE. Tessuto, completamente sfoderabile. Pelle, cuscini seduta e schienale sfoderabili.

CUSCINI SCHIENALE. In poliuretano espanso - possibilità di scelta in piuma d'oca vergine canalizzata, rivestimento cotone bianco 100%.

CUSCINI SEDUTA. In poliuretano espanso ad alta resilienza rivestito in fibra - possibilità di scelta piuma d'oca con supporto in poliuretano espanso.

PIEDI. In PVC nero h. mm 80.

STRUCTURE. In solid wood covered with high resilience, variable-density polyurethane foam and a breathable heat-bonded quilted fiber casing laminated to a white cotton fabric. Suspension provided by high-rubber-content elastic webbing.

COVER. Removable fabric. Leather, only cushions removable.

BACKREST CUSHIONS. In polyurethane foam with dacron - possibility choice with channeled goose down padding covered with 100% cotton.

SEAT CUSHION. In polyurethane foam with dacron - possibility choice with channeled goose down padding covered with 100% cotton.

FEET. In black PVC 80 mm high.

ELEMENTI SINGOLI / ELEMENTS

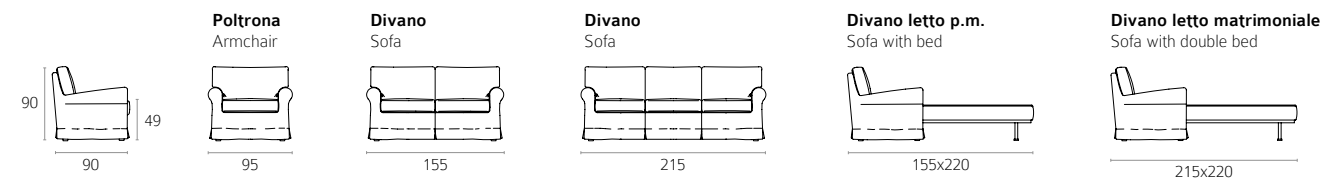



IN&OUT Design Cesare Ballabio

STRUTTURA. In legno massello rivestito con poliuretano espanso a quote differenziate ad alta resistenza e ricoperto da fibra termolegata e traspirante accoppiata con tela di cotone bianca. Molleggio garantito da cinghie elastiche ad alto componente di caucciù.
RIVESTIMENTO FINALE. Tessuto, completamente sfoderabile. Pelle, cuscini seduta e schienale sfoderabili.
CUSCINI SCHIENALE. In piuma d'oca vergine canalizzata. Rivestimento in 100% cotone bianco.
CUSCINI SEDUTA. In poliuretano espanso ad alta resilienza rivestito in fibra e resinati.
MECCANISMO. Sistema di estrazione sedute mediante scorrimento su telaio in ferro.
 Disponibile anche fisso.

BASAMENTO. Laterale - tubolari metallo - h. mm 25 - finiture disponibili: cromato - brunito opaco - satinato.

STRUCTURE. In solid wood covered with high resilience, variable-density polyurethane foam and a breathable heat-bonded quilted fiber casing laminated to a white cotton fabric. Suspension provided by high-rubber-content elastic webbing.
COVER. Removable fabric. Leather, only cushions removable.
BACKREST CUSHIONS. Are made with channeled goose down covered with 100% of white cotton.
SEAT CUSHION. In polyurethane foam with high resilience covered with dacron.
MECHANISM. Exit seating system by sliding on an iron frame. Also available without system.
BASEMENT. Lateral - tubular metal - h. mm 25 - finishes: chromed - matt burnished - satined.

ELEMENTI SINGOLI / ELEMENTS

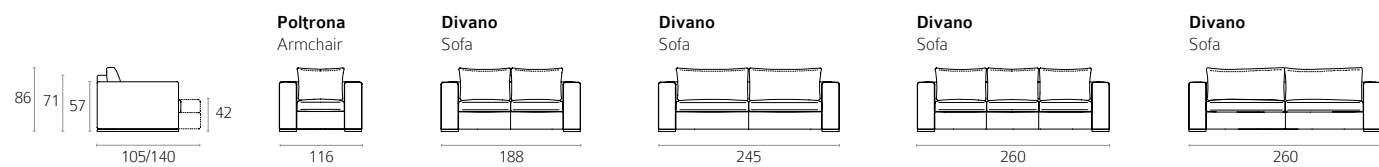

FINITURE PIEDE / FEET FINISHES

METALLO / METAL



Cromato Chromed
Satinato Satined
Brunito opaco Matt burnished



JOIN Design CRS Barzaghi Salotti

STRUTTURA. In legno massello rivestito con poliuretano espanso a quote differenziate ad alta resistenza e ricoperto da fibra termolegata e traspirante accoppiata con tela di cotone bianca. Molleggio garantito da cinghie elastiche ad alto componente di caucciù.
RIVESTIMENTO FINALE. Tessuto completamente sfoderabile. Pelle, cuscini seduta e schienale sfoderabili.
CUSCINI SCHIENALE. In piuma d'oca vergine lavata e sterilizzata, canalizzata e rivestita in cotone 100%.
CUSCINI SEDUTA. Seduta in piuma d'oca canalizzata con inserto portante in poliuretano espanso ad alta resilienza.
PIEDI. Metallo h. mm 55 Finiture: cromato - brunito opaco - satinato.

STRUCTURE. In solid wood covered with high resilience, variable-density polyurethane foam and a breathable heat-bonded quilted fiber casing laminated to a white cotton fabric. Suspension provided by high-rubber-content elastic webbing.
COVER. Completely removable fabric. Leather, cushions removable.
BACKREST CUSHIONS. Are filled with washed and sterilized channeled goose down.
SEAT CUSHION. Are made with channeled goose down padding with structural support insert in polyurethane foam.
FEET. Metal h. mm 55. Finishes: chromed - matt burnished - satined.

ELEMENTI SINGOLI / ELEMENTS

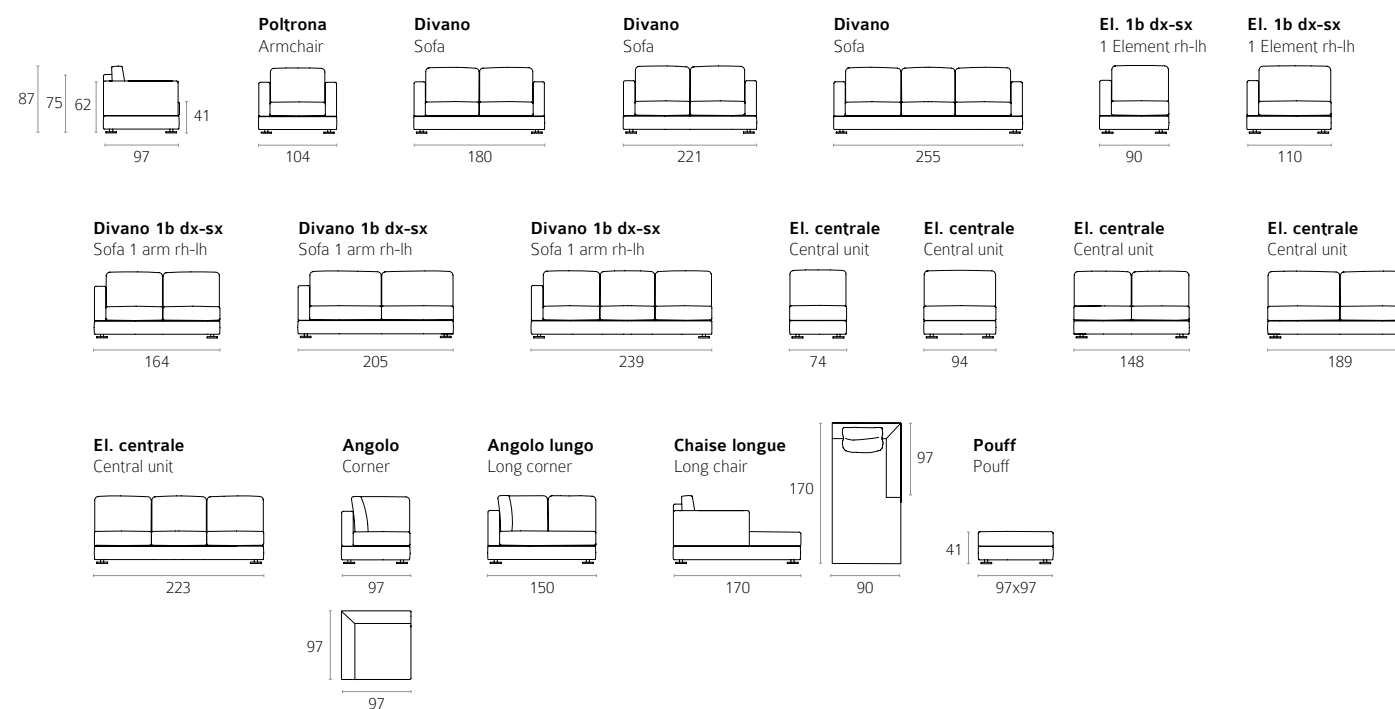

FINITURE PIEDE / FEET FINISHES

METALLO / METAL



Cromato Chromed
Satinato Satined
Brunito opaco Matt burnished



LADY Design CRS Barzaghi Salotti

STRUTTURA. In legno massello rivestito con poliuretano espanso a quote differenziate ad alta resistenza. Molleggio garantito da cinghie elastiche ad alto componente di caucciù.
PRERIVESTIMENTO struttura. Trapuntino di piuma d’oca vergine canalizzata (certificata Assopiuma, Etichetta Oro) rivestimento cotone bianco 100%.
RIVESTIMENTO FINALE. Tessuti e pellami in molteplici tipologie. Completamente sfoderabile nella versione in tessuto. Cuscinate sfoderabili nella versione in pelle.
CUSCINI SCHIENALE. In piuma d’oca vergine canalizzata rivestito in cotone 100% bianco.
CUSCINI SEDUTA. In piuma d’oca canalizzata, con inserto portante in poliuretano espanso ad alta resilienza e ricoperto in cotone 100% bianco.
PIEDI. Metallo h. mm 4 Disponibile nelle seguenti finiture: cromato – brunito.
BASAMENTO Metallo h. mm. 3. Disponibile nelle seguenti finiture: cromato - brunito opaco.

STRUCTURE. In solid wood covered with high resilience, variable-density polyurethane foam and a breathable heat-bonded quilted fiber casing laminated to a white cotton fabric. Suspension provided by high-rubber-content elastic webbing.
PRE-COVERING. Frame covered with feather quilt (certified Assopiuma, Gold Label) and white cotton 100%.
COVER. Removable fabric in different types. Leather (only cushions removable) in different types.
BACKREST CUSHIONS. Are made with channeled goose down padding covered by 100% white cotton.
SEAT CUSHION. Are made with channeled goose down padding with structural support insert in polyurethane foam.
FEET. Metal h. mm 4 Available with following finishes: chromed – burnished.
BASEMENT Metal h. mm 3. Available with following finishes: chromed - matt burnished.

ELEMENTI SINGOLI / ELEMENTS

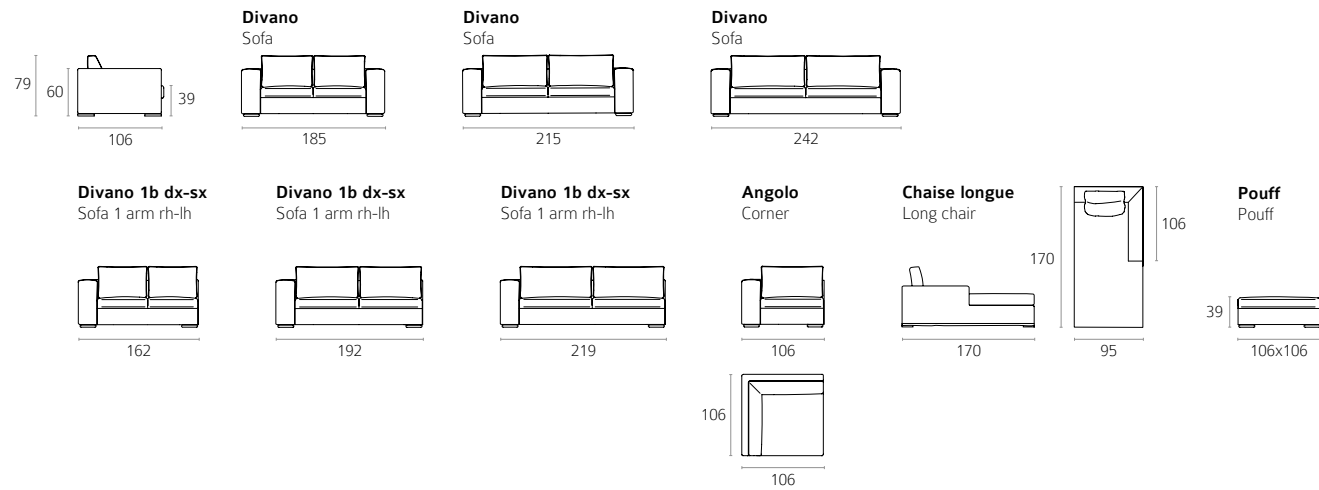

FINITURE PIEDE / FEET FINISHES

METALLO / METAL

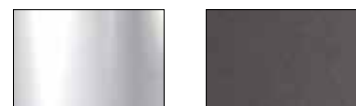

Cromato Chromed
Brunito opaco Matt burnished



MANHATTAN Design CRS Barzaghi Salotti

STRUTTURA. In legno massello rivestito con poliuretano espanso a quote differenziate ad alta resistenza. Molleggio garantito da cinghie elastiche ad alto componente di caucciù.
RIVESTIMENTO FINALE. Tessuto completamente sfoderabile. Pelle, cuscini seduta e schienale sfoderabili.
CUSCINI SCHIENALE. In piuma d’oca vergine lavata e sterilizzata, canalizzata e rivestita in cotone 100%.
CUSCINI SEDUTA. In piuma d’oca canalizzata con inserto portante in poliuretano espanso ad alta resilienza.
PIEDI. In PVC nero h. mm. 4

STRUCTURE. In solid wood covered with high resilience, variable-density polyurethane foam and a breathable heat-bonded quilted fiber casing laminated to a white cotton fabric. Suspension provided by high-rubber-content elastic webbing.
COVER. Completely removable fabric. Leather, cushions removable.
BACKREST CUSHIONS. Aare filled with washed and sterilized channeled goose down.
SEAT CUSHION. Are made with channeled goose down padding with structural support insert in polyurethane foam.
FEET. Black PVC h. mm. 4

ELEMENTI SINGOLI / ELEMENTS

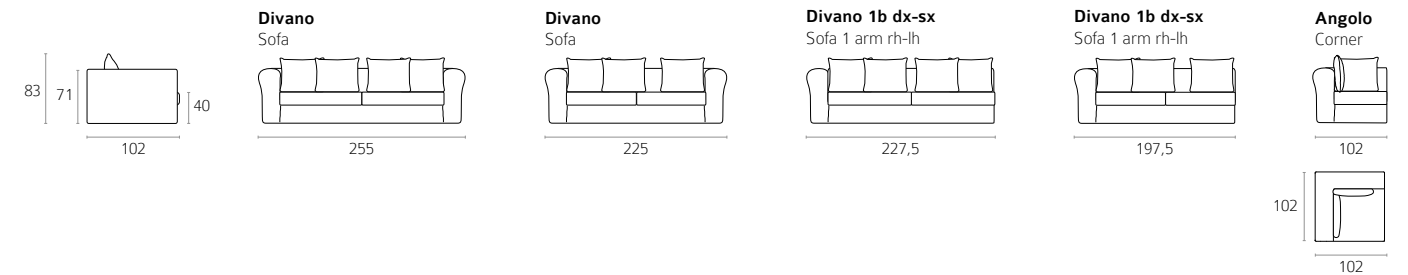



MUST Design CRS Barzaghi Salotti

STRUTTURA. In legno massello rivestito con poliuretano espanso a quote differenziate ad alta resistenza. Molleggio garantito da cinghie elastiche ad alto componente di caucciù.

RIVESTIMENTO FINALE. Tessuti e pellami in molteplici tipologie. Completamente sfoderabile nella versione in tessuto. Cuscinate sfoderabili nella versione in pelle.

CUSCINI SCHIENALE. In piuma d'oca vergine canalizzata (certificata Assopiuma, Etichetta Oro).

CUSCINI SEDUTA. In piuma d'oca canalizzata (certificata Assopiuma, Etichetta Oro) con inserto portante in poliuretano espanso ad alta resilienza.

PIEDI. In PVC nero h. mm 25.

STRUCTURE. In solid wood covered with high resilience, variable-density polyurethane foam and a breathable heat-bonded quilted fiber casing laminated to a white cotton fabric. Suspension provided by high-rubber-content elastic webbing.

COVER. Removable fabric in different types. Leather (only cushions removable) in different types.

BACKREST CUSHIONS. Are made with channeled goose down padding (certified Assopiuma, Gold Label) with structural support insert in polyurethane foam. Shaped to put the cushion in two positions is correlated with a lumbar support in goose down padding (certified Assopiuma, Gold Label) and an insert in polyurethane foam.

SEAT CUSHION. Are made with channeled goose down padding (certified Assopiuma, Gold Label) with structural support insert in polyurethane foam.

FEET. In black PVC 25 mm high.

ELEMENTI SINGOLI / ELEMENTS

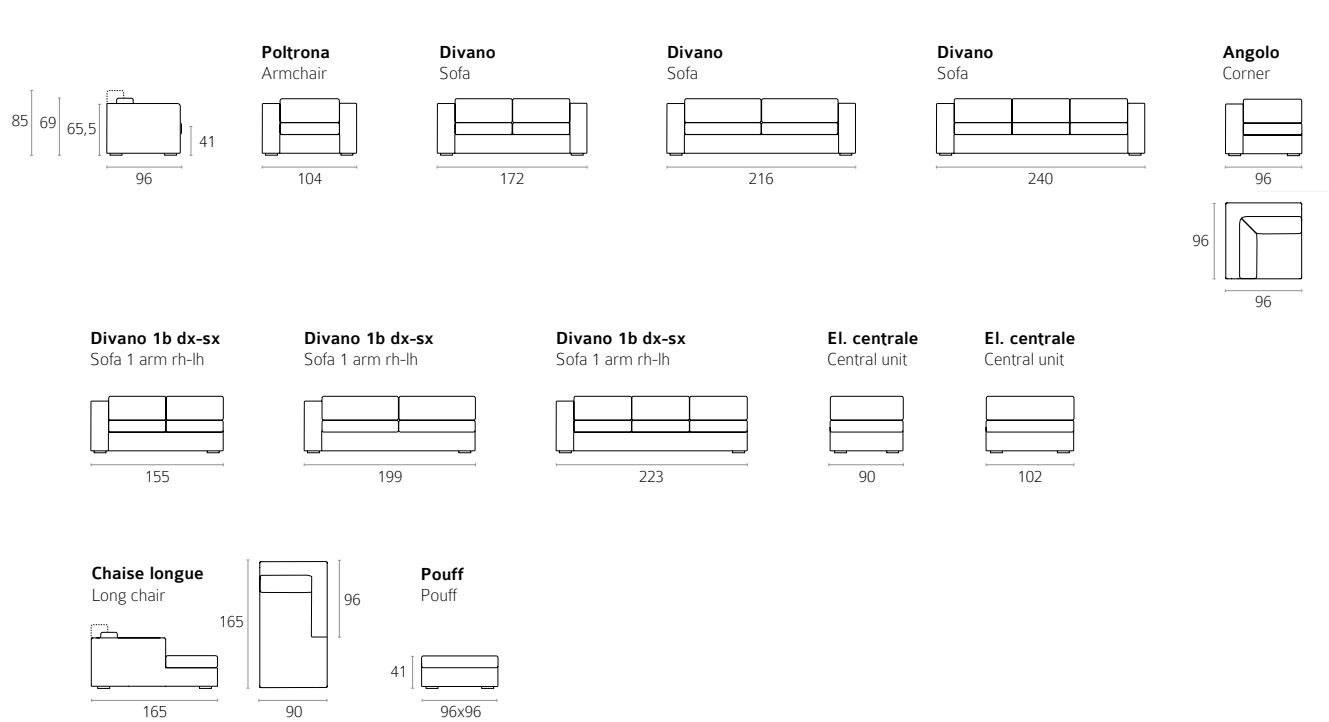

MUST OVER Design CRS Barzaghi Salotti

STRUTTURA. In legno massello rivestito con poliuretano espanso a quote differenziate ad alta resistenza. Molleggio garantito da cinghie elastiche ad alto componente di caucciù.

RIVESTIMENTO FINALE. Tessuti e pellami in molteplici tipologie. Completamente sfoderabile nella versione in tessuto. Cuscinate sfoderabili nella versione in pelle.

CUSCINI SCHIENALE. In piuma d'oca vergine canalizzata (certificata Assopiuma, Etichetta Oro) con supporto in poliuretano espanso e dacron.

CUSCINI SEDUTA. In poliuretano espanso ad alta resilienza e fibra termolegata e traspirante accoppiata con tela di cotone bianca.

BASAMENTO. H. mm 95 - finiture: cromo - brunito opaco.

STRUCTURE. In solid wood covered with high resilience, variable-density polyurethane foam and a breathable heat-bonded quilted fiber casing laminated to a white cotton fabric. Suspension provided by high-rubber-content elastic webbing.

COVER. Removable fabric in different types. Leather (only cushions removable) in different types.

BACKREST CUSHIONS. Are made with channeled goose down padding (certified Assopiuma, Gold Label) with structural support insert in polyurethane foam. Shaped to put the cushion in two positions is correlated with a lumbar support in goose down padding (certified Assopiuma, Gold Label) and an insert in polyurethane foam.

SEAT CUSHION. In high resilience polyurethane foam and a breathable heat-bonded quilted fiber casing laminated to a white cotton fabric.

BASEMENT. H. mm 95 - finishes: chromo - matt burnished.

ELEMENTI SINGOLI / ELEMENTS

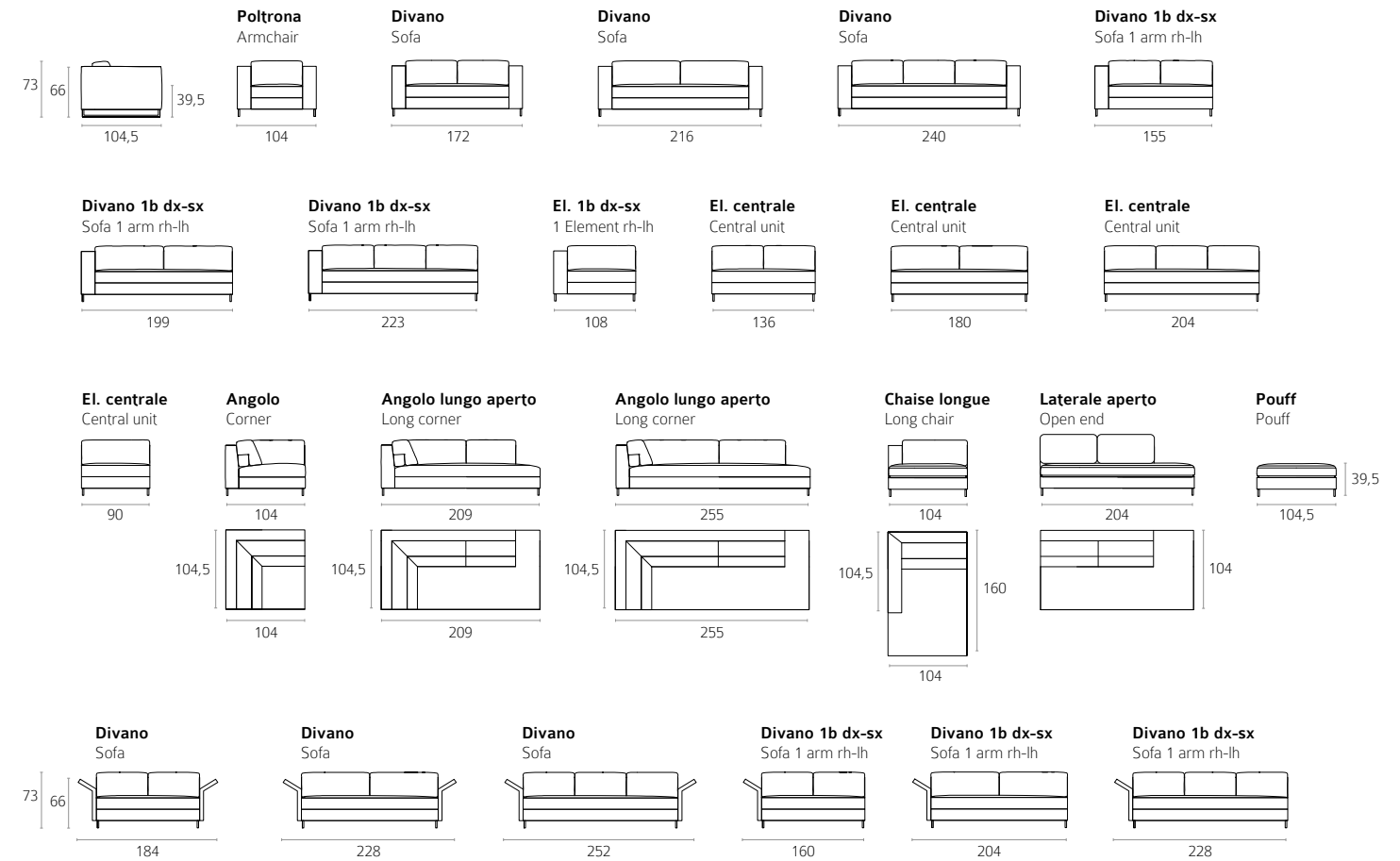

FINITURE PIEDE / FEET FINISHES

METALLO / METAL



Cromato
Chromed

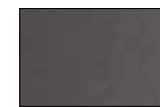

Brunito opaco
Matt burnished

MOVIMENTO / MOVEMENT

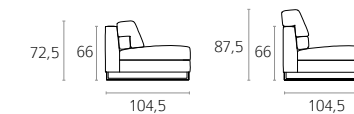



PORTLAND Design CRS Barzaghi Salotti

STRUTTURA. In legno massello rivestito con poliuretano espanso a quote differenziate ad alta resilienza. Molleggio garantito da cinghie elastiche ad alto componente di caucciù.

PRERIVESTIMENTO STRUTTURA. Trapuntino di piuma d'oca vergine canalizzata (certificata Assopiuma, Etichetta Oro) rivestimento cotone bianco 100%.

RIVESTIMENTO FINALE. Tessuti e pellami in molteplici tipologie. Completamente sfoderabile nella versione in tessuto. Cuscinate sfoderabili nella versione in pelle.

CUSCINI SCHIENALE. In piuma d'oca vergine canalizzata (certificata Assopiuma, Etichetta Oro).

CUSCINI SEDUTA. In piuma d'oca canalizzata (certificata Assopiuma, Etichetta Oro) con inserto portante in poliuretano espanso 40/em + 23/airsoft.

PIEDI. In PVC regolabili h. mm 25.

BASAMENTO. h. mm 20 - Metallo - Finiture: MA02 Brown - MA05 Smoke - Bronze

STRUCTURE. In solid wood covered with high resilience, variable-density polyurethane foam and a breathable heat-bonded quilted fiber casing laminated to a white cotton fabric. Suspension provided by high-rubber-content elastic webbing.

PRE-COVERING. Frame covered with feather quilt (certified Assopiuma, Gold Label) and white cotton 100%.

COVER. Removable fabric in different types. Leather (only cushions removable) in different types.

BACKREST CUSHIONS. Are made with channeled goose down padding (certified Assopiuma, Gold Label)

SEAT CUSHION. Are made with channeled goose down padding (certified Assopiuma, Gold Label) with structural support insert in polyurethane foam 40/em + 23/airsoft.

FEET. In black PVC adjustable 25 mm high.

BASEMENT. h. mm 20 - Metal - Finishes: MA02 Brown - MA05 Smoke - Bronze

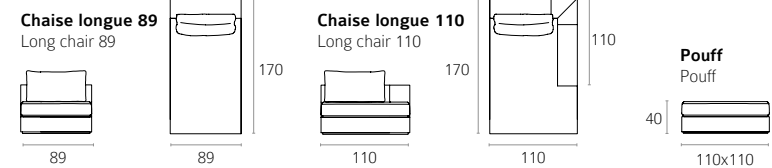
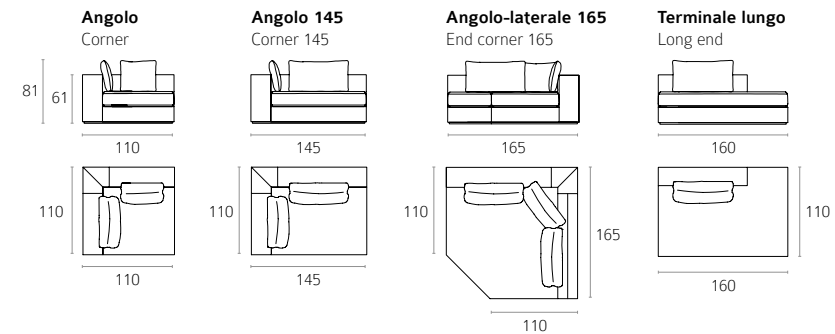

ELEMENTI SINGOLI / ELEMENTS

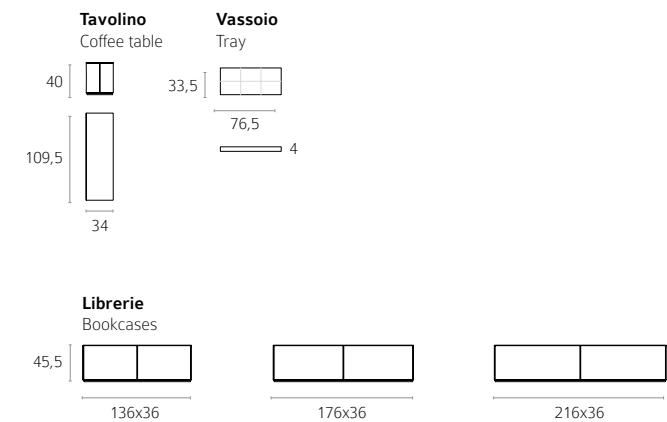
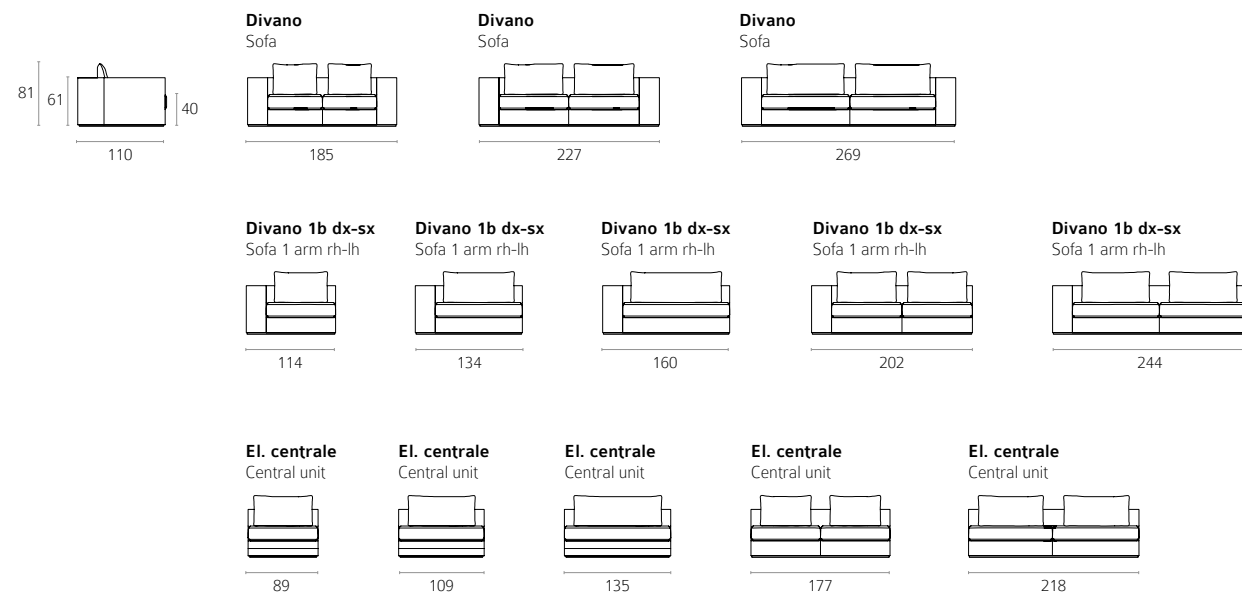

FINITURE LIBRERIA E BASAMENTO / BOOKCASES AND BASEMENT FINISHES

METALLO / METAL



FINITURE PIANI E VASSOIO / TOP AND TRY FINISHES

CUOIO / LEATHER





ROGER Design CRS Barzaghi Salotti

STRUTTURA. In legno massello rivestito con poliuretano espanso a quote differenziate ad alta resistenza e ricoperto da fibra termolegata e traspirante accoppiata con tela di cotone bianca. Molleggio garantito da cinghie elastiche ad alto componente di caucciù.
RIVESTIMENTO FINALE. Tessuto, completamente sfoderabile. Pelle, cuscini seduta e schienale sfoderabili.
CUSCINI SCHIENALE. In piuma d'oca vergine canalizzata con supporto centrale in poliuretano espanso.
CUSCINI SEDUTA. In poliuretano espanso ad alta resilienza rivestito in fibra.
PIEDI. Metallo - H. mm 40 - finiture disponibili: cromato - brunito opaco. Legno - H. mm 40 - finiture disponibili: wengè - noce.

STRUCTURE. In solid wood covered with high resilience, variable-density polyurethane foam and a breathable heat-bonded quilted fiber casing laminated to a white cotton fabric. Suspension provided by high-rubber-content elastic webbing.
COVER. Removable fabric. Leather, only cushions removable.
BACKREST CUSHIONS. Are made with channeled goose down.
SEAT CUSHION. In polyurethane foam with high resilience covered with dacron.
FEET. Metal - H. mm 40 - finishes: chromed - matt burnished. Wood - H. mm 40 - finishes: wengè - walnut.

ELEMENTI SINGOLI / ELEMENTS

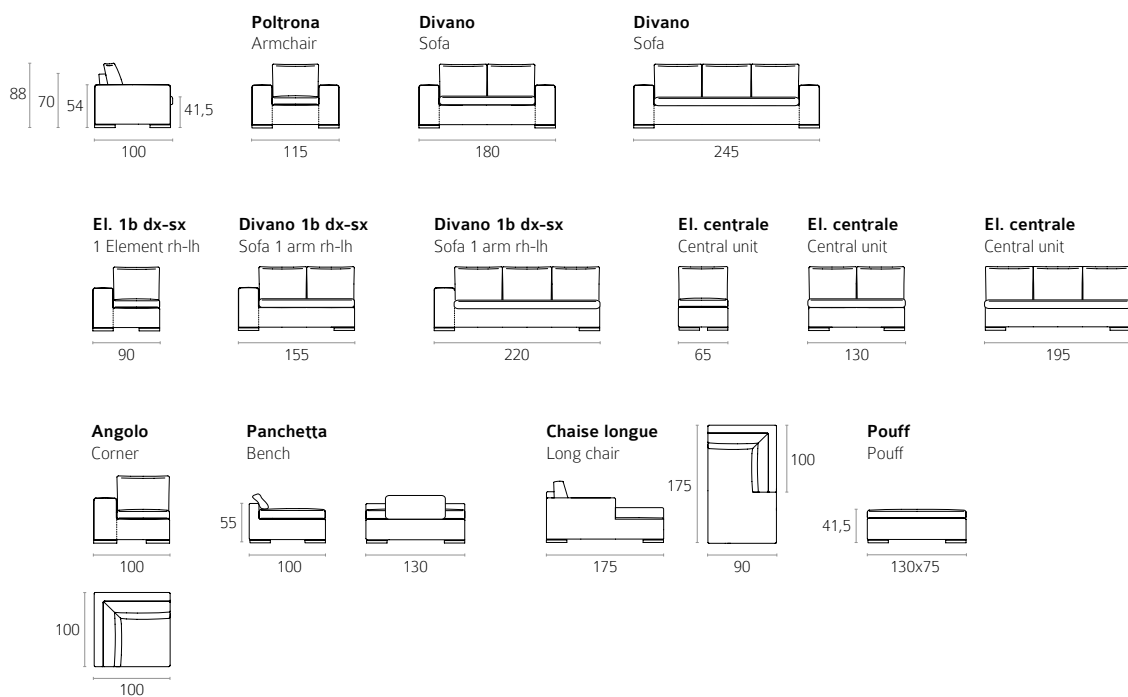

FINITURE PIEDE / FEET FINISHES

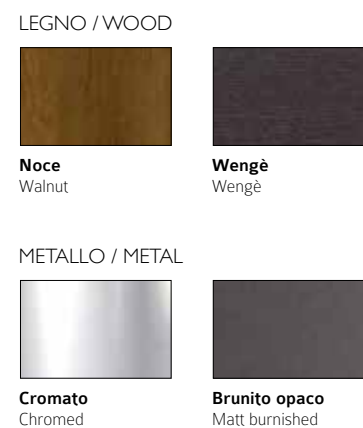

SKIP Design Cesare Ballabio

STRUTTURA. In ferro rivestito da fibra termolegata accoppiata con tela di cotone bianca.
RIVESTIMENTO FINALE. Tessuti e pellami in molteplici tipologie. Completamente sfoderabile nella versione in tessuto. Cuscinate sfoderabili nella versione in pelle.
CUSCINI SCHIENALE. In piuma d'oca vergine canalizzata (certificata Assopiuma, Etichetta Oro).
CUSCINI SEDUTA. In piuma d'oca canalizzata (certificata Assopiuma, Etichetta Oro) con inserto portante in poliuretano espanso ad alta resilienza.
PIEDI. Metallo h. mm 195. Disponibile nelle seguenti finiture: cromato - brunito opaco.
BASAMENTO. Slitte metallo h. mm 195. Disponibile nelle seguenti finiture: MA02 brown - MA05 smoke.

STRUCTURE. In iron covered by fiber casing laminated to a white cotton fabric.
COVER. Removable fabric in different types. Leather (only cushions removable) in different types.
BACKREST CUSHIONS. Are made with channeled goose down padding (certified Assopiuma, Gold Label).
SEAT CUSHION. Are made with channeled goose down padding (certified Assopiuma, Gold Label) with structural support insert in polyurethane foam.
FEET. Metal h. mm 195. Available with following finishes: chromed - matt burnished.
BASEMENT. Sledges metal h. mm 195. Available with following finishes: MA02 brown - MA05 smoke.

ELEMENTI SINGOLI / ELEMENTS

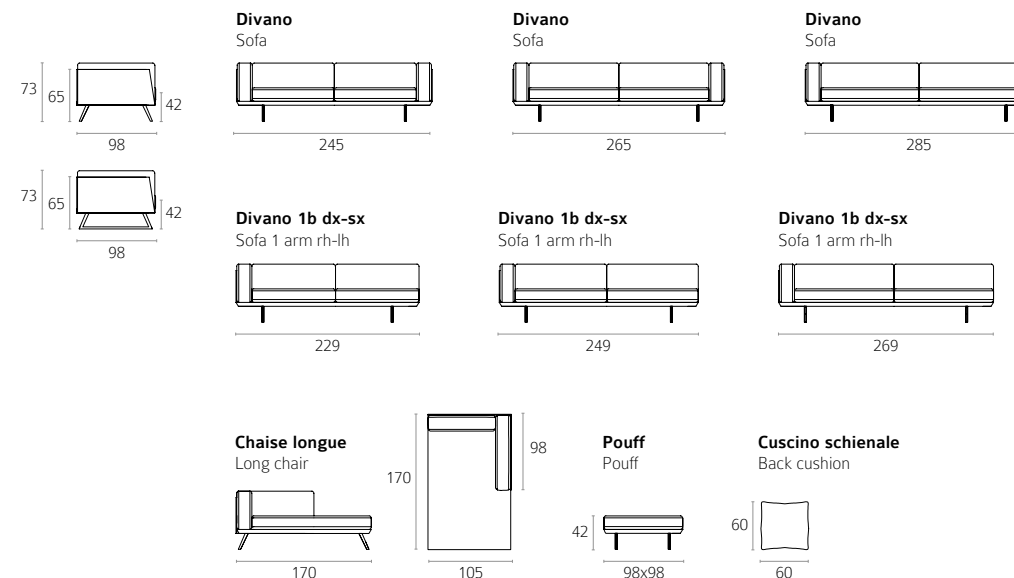

FINITURE PIEDE / FEET FINISHES



FINITURE BASAMENTO / BASEMENT FINISHES

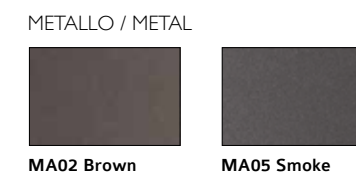



TIME Design CRS Barzaghi Salotti

STRUTTURA. In legno massello rivestito con poliuretano espanso a quote differenziate ad alta resistenza e ricoperto da fibra termolegata e traspirante accoppiata con tela di cotone bianca. Molleggio garantito da cinghie elastiche ad alto componente di caucciù e ad alta portata.

RIVESTIMENTO FINALE. Tessuto, completamente sfoderabile. Pelle, cuscini seduta e schienale sfoderabili.

CUSCINI SCHIENALE. In piuma d'oca vergine canalizzata.

CUSCINI SEDUTA. In poliuretano espanso ad alta resilienza rivestito in fibra accoppiata.

PIEDI. Metallo - H. mm 65 - finiture disponibili: cromato.

STRUCTURE. In solid wood covered with high resilience, variable-density polyurethane foam and a breathable heat-bonded quilted fiber casing laminated to a white cotton fabric. Suspension provided by high-rubber-content elastic webbing.

COVER. Removable fabric. Leather, only cushions removable.

BACKREST CUSHIONS. Are made with channeled goose down.

SEAT CUSHION. In polyurethane foam with high resilience covered with dacron.

FEET. Metal - mm 65 - finishes: chromed.

ELEMENTI SINGOLI / ELEMENTS

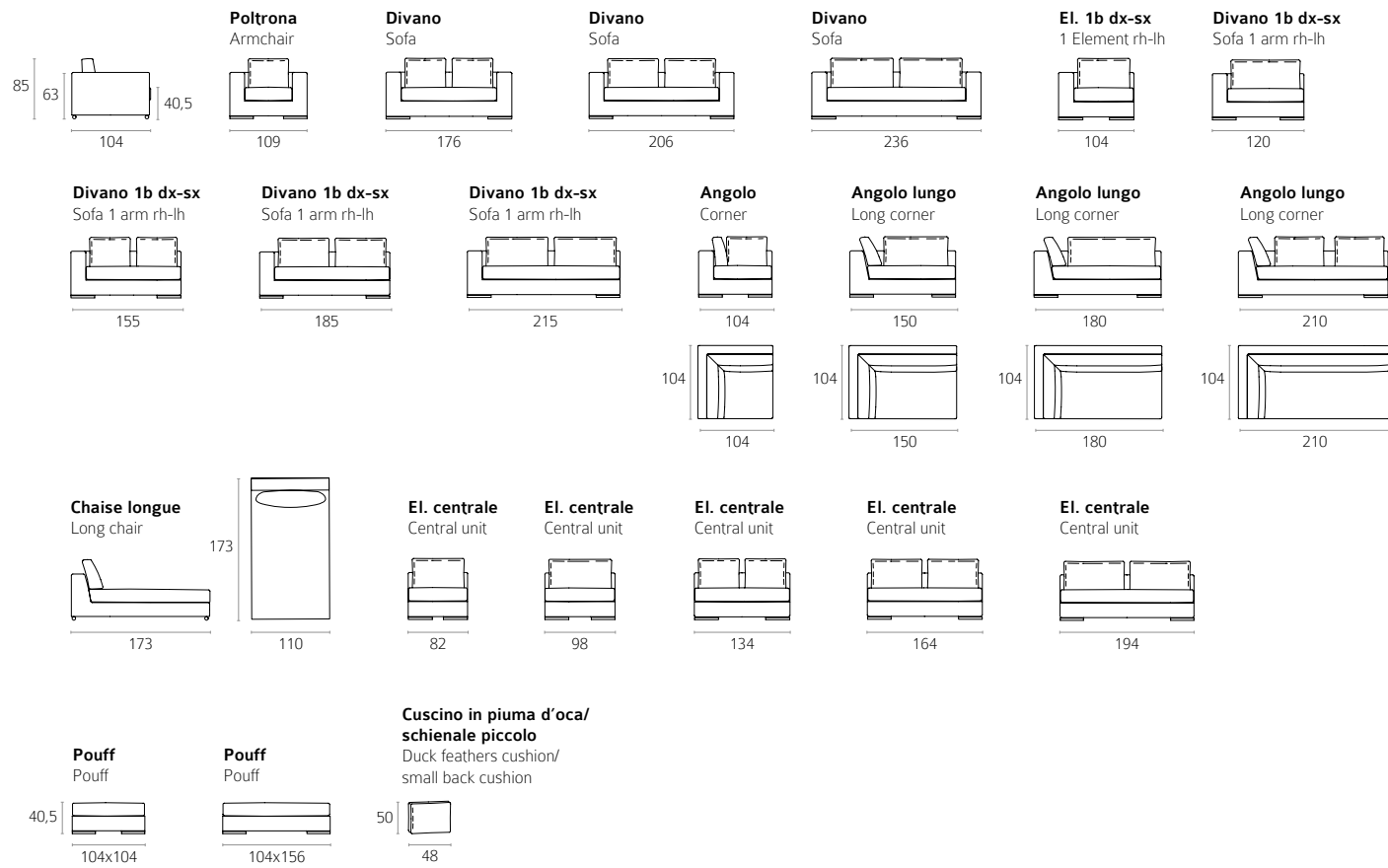

FINITURE PIEDE / FEET FINISHES

METALLO / METAL



Cromato
Chromed



YOUNG Design CRS Barzaghi Salotti

STRUTTURA. In legno massello rivestito con poliuretano espanso a quote differenziate ad alta resilienza. Molleggio garantito da cinghie elastiche ad alto componente di caucciù.

PRERIVESTIMENTO STRUTTURA. Trapuntino di piuma d'oca vergine canalizzata (certificata Assopiuma, Etichetta Oro) rivestimento cotone bianco 100%.

RIVESTIMENTO FINALE. Tessuti e pellami in molteplici tipologie. Completamente sfoderabile sia nella versione in tessuto che in pelle.

CUSCINI SCHIENALE. In piuma d'oca vergine canalizzata (certificata Assopiuma, Etichetta Oro).

CUCITURE. A piattina nella versione in tessuto. Taglio vivo nella versione in pelle.

PIEDI. In PVC nero h. mm 20.

STRUCTURE. In solid wood covered with high resilience, variable-density polyurethane foam and a breathable heat-bonded quilted fiber casing laminated to a white cotton fabric. Suspension provided by high-rubber-content elastic webbing.

PRE-COVERING. Frame covered with feather quilt (certified Assopiuma, Gold Label) and white cotton 100%.

COVER. Completely removable in fabric and in leather.

BACKREST CUSHIONS. Are made with channeled goose down padding (certified Assopiuma, Gold Label).

STITCHING: Plucked stitching in fabric. Raw-edged in leather.

FEET. In black PVC 20 mm high.

ELEMENTI SINGOLI / ELEMENTS

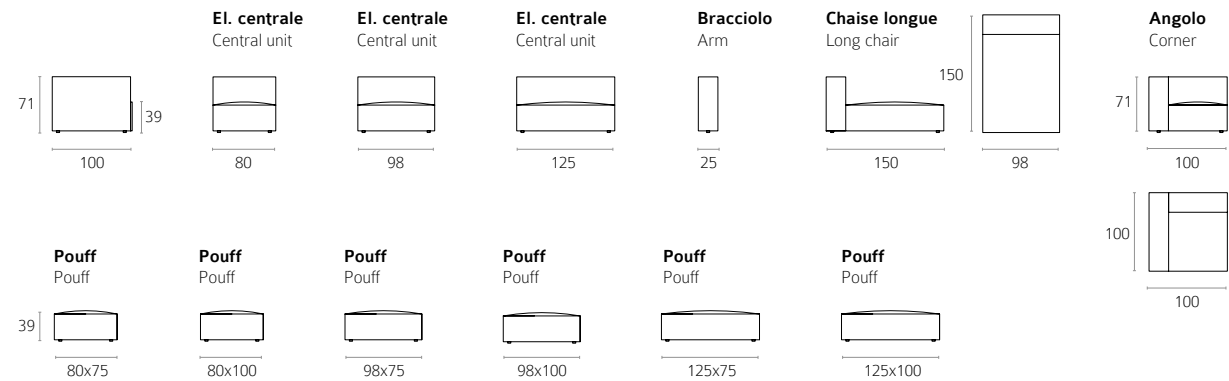

YOUNG FREE

BASI CON CUSCINI ZAVORRATI "TRAPEZ" / BASES WITH HEAVY BACKS "TRAPEZOIDAL"

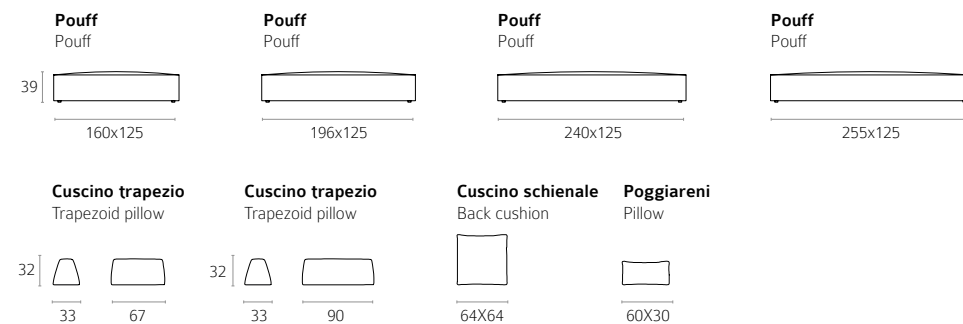



YOUNG OUTDOOR Design CRS Barzaghi Salotti

STRUTTURA. In legno idrorepellente rivestito in schiuma poliuretana a cellula aperta ad alta resilienza ricoperta da fibre per uso esterno e fodera di copertura in tessuto idrorepellente. Molleggio garantito da cinghie elastiche per uso esterno ad alto componente di caucciù.

RIVESTIMENTO FINALE. Tessuti in molteplici tipologie, completamente sfoderabile.

CUSCINI SCHIENALE. In piuma d'oca vergine canalizzata (certificata Assopiuma, Etichetta Oro).

CUCITURE. A piattina nella versione in tessuto - taglio vivo nella versione in pelle.

PIEDI. In PVC nero h. mm 20.

STRUCTURE. In solid wood, waterproof, covered with open cell structure polyurethane foam, and with fibre for outdoor and waterproof fabric. Suspension provided by high-rubber-content elastic webbing for outdoor.

COVER. Upholstery with outdoor fabrics only, fully removable.

BACKREST CUSHIONS. Are made with channeled goose down padding (certified Assopiuma, Gold Label).

STITCHING: Plucked stitching in fabric. Raw-edged in leather.

FEET. In black PVC 25 mm high.

ELEMENTI SINGOLI / ELEMENTS

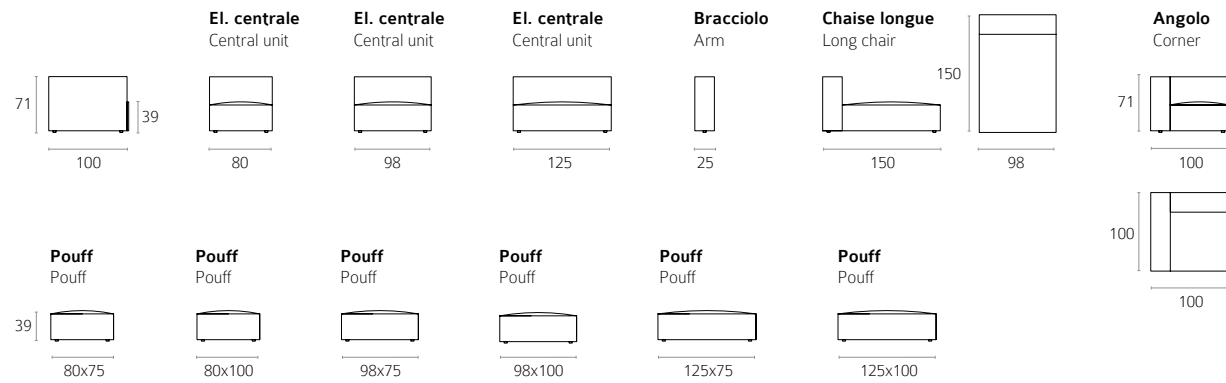

YOUNG OUTDOOR FREE

BASI CON CUSCINI ZAVORRATI "TRAPEZ" / BASES WITH HEAVY BACKS "TRAPEZOIDAL"

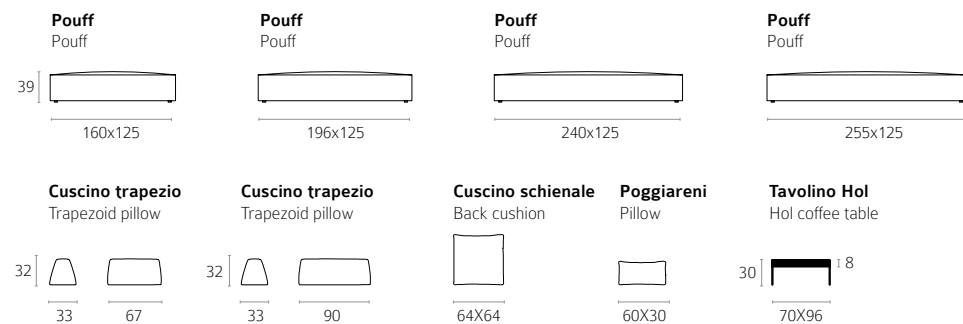

Su richiesta sono disponibili teli di copertura.
Cover sheets are available on request.

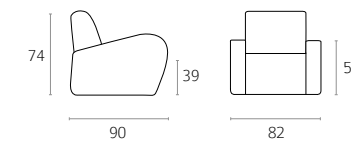

ATHENA Design Cesare Ballabio

STRUTTURA. In legno massello rivestito con poliuretano espanso a quote differenziate ad alta resistenza. Molleggio garantito da cinghie elastiche ad alto componente di caucciù.

RIVESTIMENTO FINALE. Tessuto completamente sfoderabile. Pelle, cuscino sfoderabile.

CUSCINO POGGIARENI. In poliuretano espanso e fibra termolegata e accoppiata.

CUCITURE. Profilo a contrasto in grosgrain nei colori da campionario o tessuto della collezione Barzaghi.

PIEDI. In PVC nero h. mm 20

STRUCTURE. In solid wood covered with high resilience, variable-density polyurethane foam and a breathable heat-bonded quilted fiber casing laminated to a white cotton fabric. Suspension provided by high-rubber-content elastic webbing.

COVER. FABRIC completely removable. Leather, cushion removable.

LUMBAR PILLOW. In polyurethane foam and a heat-bonded quilted fiber.

TRIM. Grosgrain in as per sample book or in collection Barzaghi fabric.

FEET. In black PVC 20 mm high.

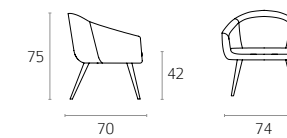
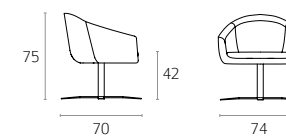

BANG Design CRS Barzaghi Salotti

STRUTTURA. In poliuretano stampato a freddo con struttura in acciaio.

RIVESTIMENTO FINALE. Tessuto e pelle - completamente sfoderabile.

CUSCINI SEDUTA. In poliuretano espanso e fibra termolegata e accoppiata.

PIEDI. h. mm 345. In legno. Finiture: Noce scuro - wengé - nero

BASAMENTO. Base girevole. Finiture: cromato - brunito opaco

STRUCTURE. In cold-cure polyurethane foam with steel frames.

COVER. FABRIC Fabric and leather completely removable.

SEAT CUSHIONS. In polyurethane foam and a heat-bonded quilted fiber

FEET. 345 mm high. In wood Finishes: Dark walnut - wengé - black

BASEMENT. Swivel base. Finishes: chromed - matt burnished

BASAMENTO GIREVOLE / SWIVEL BASEMENT

METALLO / METAL



Cromato
Chromed



Brunito opaco
Matt burnished

GAMBE / LEGS

LEGNO / WOOD



Nero
Black



Rovere moro
Dark oak

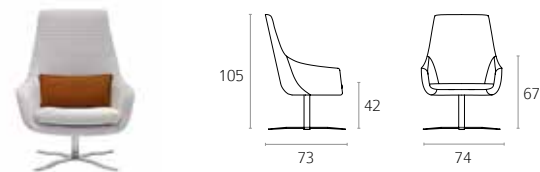

BIG Design CRS Barzaghi Salotti

STRUTTURA. In poliuretano stampato a freddo con struttura in acciaio.
RIVESTIMENTO FINALE. Tessuto e pelle completamente sfoderabile.
CUSCINO SEDUTA. In poliuretano espanso e fibra termolegata e accoppiata.
BASAMENTO. Base girevole. Finiture: cromato - brunito opaco

STRUCTURE. In cold-cure polyurethane foam with steel frames cotton fabric. Suspension provided by high-rubber-content elastic webbing.
COVER. FABRIC. Fabric and leather completely removable.
SEAT CUSHION. In polyurethane foam and a heat-bonded quilted fiber.
BASEMENT. Swivel base. Finishes: chromed - matt burnished.

BASAMENTO GIREVOLE / SWIVEL BASEMENT

METALLO / METAL



Cromato
Chromed



Brunito opaco
Matt burnished

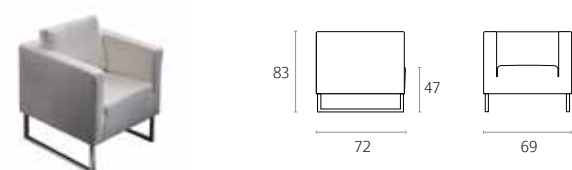

EASY2 Design CRS Barzaghi Salotti

STRUTTURA. In legno massello rivestito con poliuretano espanso a quote differenziate ad alta resistenza. Molleggio garantito da cinghie elastiche ad alto componente di caucciù.
RIVESTIMENTO FINALE. Tessuto completamente sfoderabile. Pelle, cuscino sfoderabile.
CUSCINI SCHIENALE. In poliuretano espanso e fibra termolegata e accoppiata.
SLITTE. In metallo h. mm 22. - Finiture: Cromato

STRUCTURE. in solid wood covered with high resilience, variable-density polyurethane foam and a breathable heat-bonded quilted fiber casing laminated to a white cotton fabric. Suspension provided by high-rubber-content elastic webbing.
COVER. Fabric completely removable. Leather, cushions removable.
BACKREST CUSHIONS. In polyurethane foam and a heat-bonded quilted fiber.
SLEDGES. In metal 22 mm high. - Finishes: Chromed

FINITURE BASAMENTO / BASEMENT FINISHES

METALLO / METAL



Cromato
Chromed

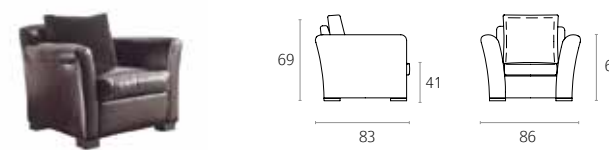

EEL Design CRS Barzaghi Salotti

STRUTTURA. In legno massello rivestito con poliuretano espanso a quote differenziate ad alta resistenza. Molleggio garantito da cinghie elastiche ad alto componente di caucciù.
RIVESTIMENTO FINALE. Tessuto e pelle. Cuscino sfoderabile.
CUSCINI SCHIENALE. in piuma d'oca vergine canalizzata.
CUSCINO SEDUTA. In piuma d'oca con supporto in poliuretano espanso.
PIEDI. H. mm 55 **LEGNO** - Finiture: Rovere moro. **METALLO** - Finiture: Chromed

STRUCTURE. In solid wood covered with high resilience, variable-density polyurethane foam and a breathable heat-bonded quilted fiber casing laminated to a white cotton fabric. Suspension provided by high-rubber-content elastic webbing.
COVER. Fabric and leather, removable cushion.
BACKREST CUSHIONS. In channeled goose down padding.
SEAT CUSHION. In goose down padding with polyurethane support.
FEET. 55 mm high. **WOOD** - Finishes: Dark brown. **METAL** - Finishes: Chromed

FINITURE PIEDE / FEET FINISHES

LEGNO / WOOD



Rovere moro
Dark brown

METALLO / METAL



Brunito opaco
Matt burnished

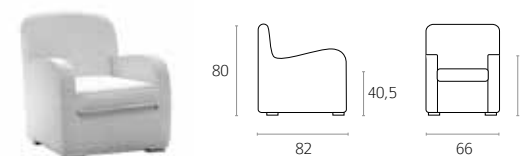

GHOST Design CRS Barzaghi Salotti

STRUTTURA. In legno massello rivestito con poliuretano espanso a quote differenziate ad alta resistenza. Molleggio garantito da cinghie elastiche ad alto componente di caucciù.
RIVESTIMENTO FINALE. Tessuto completamente sfoderabile.
CUSCINO SEDUTA. In piuma d'oca con supporto in poliuretano espanso.
PIEDI. h. 50 mm **Metallo** - Finiture: Cromato
BASAMENTO. h. 50 mm **Metallo** - Finiture: Cromato

STRUCTURE. In solid wood covered with high resilience, variable-density polyurethane foam and a breathable heat-bonded quilted fiber casing laminated to a white cotton fabric. Suspension provided by high-rubber-content elastic webbing.
COVER. Fabric completely removable.
SEAT CUSHION. In goose down padding with polyurethane support.
FEET. 50 mm high **METAL** - Finishes: Chromed
BASEMENT. 50 mm high **METAL** - Finishes: Chromed

BASAMENTO GIREVOLE / SWIVEL BASEMENT

METALLO / METAL



Cromato
Chromed

PIEDE / FEET

METALLO / METAL



Cromato
Chromed

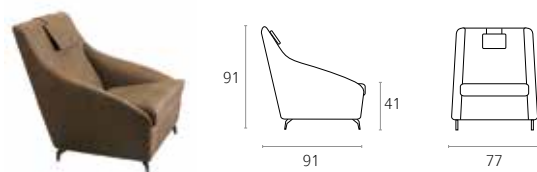

LEONIE Design CRS Barzaghi Salotti

STRUTTURA. In legno massello rivestito con poliuretano espanso a quote differenziate ad alta resistenza. Molleggio garantito da cinghie elastiche ad alto componente di caucciù.

RIVESTIMENTO FINALE. Tessuto completamente sfoderabile. Pelle, cuscino sfoderabile.

CUSCINO POGGIATESTA. In fibra termolegata.

CUSCINO SEDUTA. In poliuretano espanso e fibra termolegata e accoppiata

PIEDI. h. 90 mm Metallo - Finiture: Brunito.

BASAMENTO GIREVOLE. h. 90 mm Metallo - Finiture: Cromato.

STRUCTURE. In solid wood covered with high resilience, variable-density polyurethane foam and a breathable heat-bonded quilted fiber casing laminated to a white cotton fabric. Suspension provided by high-rubber-content elastic webbing.

COVER. Fabric completely removable. Leather, removable cushion.

HEAT CUSHION. In a heat-bonded fiber.

SEAT CUSHION. In polyurethane foam and a heat-bonded quilted fiber.

FEET. 90 mm high METAL - Finishes: Burnished.

BASEMENT. 90 mm high METAL - Finishes: Chromed.

BASAMENTO GIREVOLE / SWIVEL BASEMENT

METALLO / METAL



Cromato
Chromed



Brunito opaco
Matt burnished

GAMBE / FEET

METALLO / METAL



Brunito
Burnished

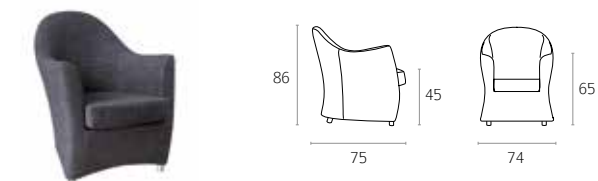

MIMI Design CRS Barzaghi Salotti

STRUTTURA. In poliuretano stampato a freddo con struttura in acciaio.

RIVESTIMENTO FINALE. Tessuto e pelle completamente sfoderabile.

CUSCINI SEDUTA. In poliuretano espanso e fibra termolegata e accoppiata.

PIEDI. h. mm 40 - Metallo satinato.

STRUCTURE. In cold-cure polyurethane foam with steel frames.

COVER. Fabric and leather completely removable.

SEAT CUSHIONS. In polyurethane foam and a heat-bonded quilted fiber.

FEET. 40 mm high - Satined metal.

PIEDE / FEET

METALLO / METAL



Satinato
Satined

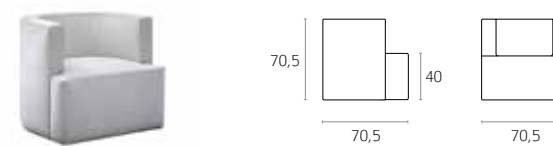

MOOD Design CRS Barzaghi Salotti

STRUTTURA. In legno massello rivestito con poliuretano espanso a quote differenziate ad alta resistenza. Molleggio garantito da cinghie elastiche ad alto componente di caucciù.

RIVESTIMENTO FINALE. Tessuto e pellame - completamente sfoderabile.

PIEDI. h. 20 mm in PVC nero.

STRUCTURE. In solid wood covered with high resilience, variable-density polyurethane foam and a breathable heat-bonded quilted fiber casing laminated to a white cotton fabric. Suspension provided by high-rubber-content elastic webbing.

COVER. Fabric and leather completely removable.

FEET. 20 mm high - black PVC.



SOFT POUF Design CRS Barzaghi Salotti

STRUTTURA. Involucro contenente palline di polistirolo espanso ad alta resistenza.

RIVESTIMENTO. Disponibile in tessuto o pelle e tessuto da esterno. Completamente sfoderabile.

STRUCTURE. Envelope containing highly resistant expanded polystyrene pellets.

COVER. Available in fabric or leather and outdoor fabric. Completely removable.



ROUND Design Cesare Ballabio

STRUTTURA. Metallo verniciato con polveri in forni di polimerizzazioni.
 FINITURA. MA02 brown - MA05 smog - BI10 white - dark grey - Bronze.
 TOP. Diam. mm 900 - mm 1220 (solo per tavolini diam mm 880 e mm 1200).
 FINITURE TOP. Marmo Carrara - Calacatta - Grafite Gray - Emperador.

STRUCTURE. Powder coated metal in polymerization furnaces.
 FINISHES. MA02 brown - MA05 smog - BI10 white - dark grey - Bronze.
 TOP. Diam. mm 900 - mm 1220 (only for coffee tables diam mm 880 and mm 1200).
 FINISHES TOP. Carrara Marble - Calacatta - Grafite Gray - Emperador.

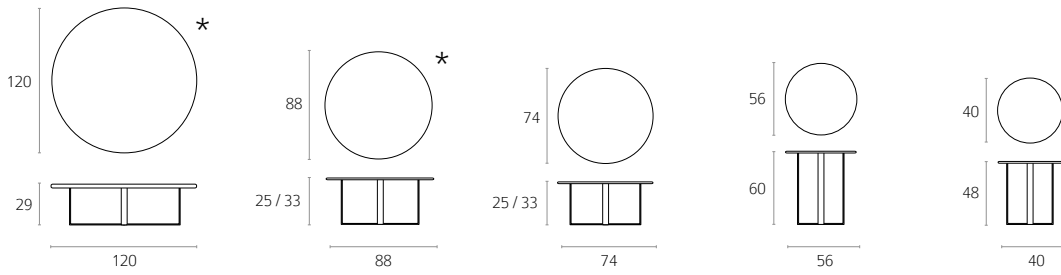

★ Disponibile anche con Top in marmo. Finiture a pagina 125.
 Available also with marble Top. Finishes on page 125.

METALLO / METAL



SQUARE 1 Design Cesare Ballabio

STRUTTURA. Legno - Metallo.
 FINITURE LEGNO. Laccato lucido bianco - Laccato opaco bianco
 FINITURE METALLO. MA05 smoke.

STRUCTURE. Wood - Metal.
 FINISHES WOOD. Glossy lacquered white - Matt lacquered white.
 FINISHES METAL. MA05 Smoke.

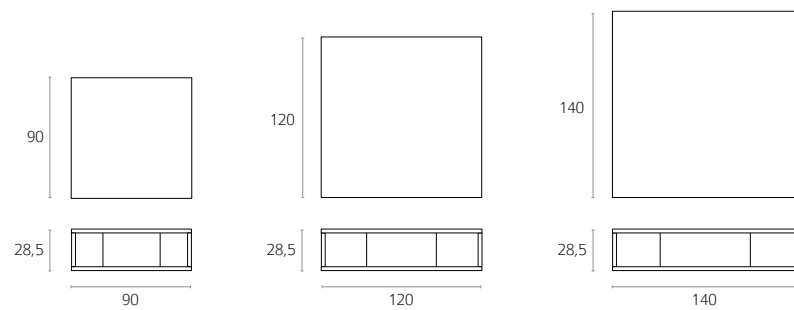

★ La versione da cm.140 è disponibile solo in metallo.
 Size cm.140 is available only in metal version.

LEGNO / WOOD



METALLO / METAL



SQUARE 2 Design Cesare Ballabio

STRUTTURA. Legno - Metallo.
 FINITURE LEGNO. Laccato lucido bianco - Laccato opaco bianco
 FINITURE METALLO. MA05 smoke.

STRUCTURE. Wood - Metal.
 FINISHES WOOD. Glossy lacquered white - Matt lacquered white.
 FINISHES METAL. MA05 Smoke.

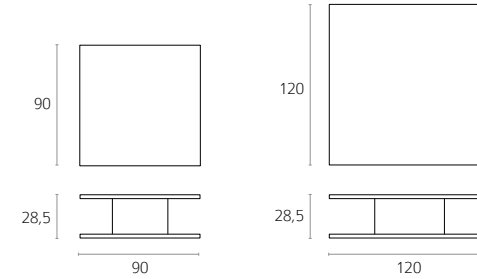

LEGNO / WOOD



TRAY Design Cesare Ballabio

STRUTTURA. Metallo verniciato con polveri in forni di polimerizzazioni.
 FINITURE. MA02 brown - MA05 smog - BI10 white - dark grey - Bronze.
 TOP. Legno.
 FINITURE TOP. Rovere chiaro - Rovere moro - Rovere grigio.

STRUCTURE. Powder coated metal in polymerization furnaces.
 FINISHES. MA02 brown - MA05 smog - BI10 white - dark grey - Bronze.
 TOP. Wood.
 FINISHES TOP. Natural oak - Dark oak - Grey oak.

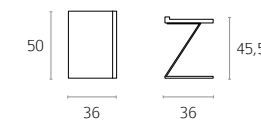

BASE / BASE

METALLO / METAL



PIANO / TOP

LEGNO / WOOD

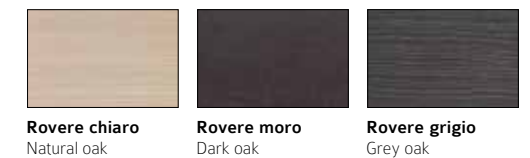

BARZAGHISALOTTI

Barzagli salotti s.r.l. - Via della Tecnica, 3/A - 20833 Birone di Giussano (Mb)
Showroom: Via Piave, 5/7 - 20833 Giussano (Mb) - Tel. +39 0362.850.117 r.a. - Fax +39 0362.354.247
www.barzaghisalotti.it - barzagli@barzaghisalotti.it