



Casamilano

Casamilano

sofa		chair	
city	7	kelly	173
suite	19	brigitte	177
pillopipe	25	elsa	181
hamptons/18	35	royale	185, 187
plaza	45	diana	189
royale	49, 51	arne	191
arne	53	quadra	195
francesca	57	costanza	197
		magenta	199
armchair		table	
ada	61	arne	203
carmen	65	kandinsky	213
liz	69	bridge	219
lea	73	empire	223
baby royale	75		
royale	77	accessories	
dhora	79	atlante	229
magenta	81, 83	ernest	231
arne	85, 89		
nana	91	lamp	
sophie	93	shard	234, 237
big	95	andromeda	239
chloe	97	sign	241
ottoman		vendome	242
tabouret	100	viola	242
petite lea	101	elettra bronze	243
hyatt	103	viola XL	244
		jackie	245
small table		mirror	
dupré	107/109	carrè	248, 249
mondrian	111	specchio	250, 251
atlante	113	vittoria	253
berlino	115	reverso	255
lugano	116		
bollywood	118	bed	
bollywood bronze	119	majestic	259
arne	121	westin	263
low table		astoria	267
arne	125	vanity	271
aldo	131	royale capitonè	275
dupré	135	royale	279
accademia	137	pillopipe	281
mondrian	141	jacopo	283
rocco	143		
bryant	145		
cabinet			
mondrian/17	149		
klea	153		
orlando/17	155		
garbo	159		
arne	163, 167		
mondrian	169		

Il racconto della nostra storia

The tale of our story



Casamilano nasce nel 1998 dal desiderio di Anna, Carlo ed Elena Turati di realizzare un progetto per la casa di pensiero internazionale, debuttando al Salone del Mobile di Milano nell'aprile dello stesso anno.

La famiglia Turati da generazioni opera nel campo dell'arredamento. Nel 1929 il nonno Carlo inizia, con i figli un'attività artigiana che ben presto si sviluppa diventando una piccola fabbrica di mobili. Negli anni '60, a seguito del cambiamento di gusto e stile avvertito dal mercato, il figlio Giuseppe (Peppino per gli amici) conferisce all'azienda un nuovo indirizzo, creando così Tisettanta, coinvolgendo architetti di fama internazionale quali Gae Aulenti, Vico Magistretti, Angelo Mangiarotti, Carlo Bartoli, Annig Sarian, Antonio Citterio.

Nell'azienda di famiglia, i figli di Giuseppe si occupano rispettivamente Anna dell'area creativa affiancando il papà e Carlo dell'area commerciale.

Usciti dall'azienda nel '97, Anna, Carlo e Elena decidono, con il papà, nel '98 di creare Casamilano, azienda che negli anni ha saputo imporsi sviluppando nel mondo una distribuzione selezionata, collaborando con designers internazionali, il cui stile creativo corrisponde alle caratteristiche del progetto.

Le collezioni Casamilano, rigorosamente made in Italy, uniscono eleganza nel design e funzionalità. La scelta dei materiali, sapientemente accostati tra loro e ricercati in ogni dettaglio, ha prodotto oggetti unici per la casa contemporanea.

Casamilano was founded in 1998 by Anna, Carlo and Elena Turati with the aim of creating a home project of international scope. It made its debut at the Milan Furniture Fair in April of that year. The Turati family has worked for generations in the furnishing field. In 1929, grandfather Carlo founded with his sons a handicraft business that soon developed into a small furniture company. In the 60s, following the change of taste and style recorded on the market, Giuseppe (called Peppino by his friends) gave the company a new course and created Tisettanta, involving internationally renowned architects such as Gae Aulenti, Vico Magistretti, Angelo Mangiarotti, Carlo Bartoli, Annig Sarian, Antonio Citterio.

In the family's Company, Giuseppe's daughter Anna manages the creative area together with her father, while Carlo manages the commercial area.

Once left the family's Company in 1997, the following year Anna, Carlo and Elena decided, with their father to create Casamilano, a Company that has been able over the years to impose itself and develop worldwide a selected distribution channel.

Casamilano cooperates with international designers, whose creative style corresponds to the features of its project. Casamilano collections, rigorously made in Italy, combine design elegance and functionality. The choice of wisely mixed materials and the care of details, produce unique objects for the contemporary home.

Casamilano

THE NEW ELEGANCE

La nuova eleganza di Casamilano, uno stile internazionale che si apre al mondo.

Per continuare ad affermare la propria identità la collezione Casamilano, contemporanea e dall'eleganza borghese, ricercata nei materiali, nei dettagli e nelle lavorazioni, si arricchisce di nuove contaminazioni.

Un mix di accostamenti inediti dove, al rigore elegante, si aggiunge un'atmosfera informale di vivere la casa, confermando il fascino e lo stile senza tempo della collezione Casamilano.

The new elegance of Casamilano, an international style that opens to the world.

To carry on its own identity, Casamilano collection, contemporary and with a bourgeois elegance, refined in materials, details and craftsmanship, has been enriched by new contaminations.

A mix of unusual combinations where the rigorous elegance is now combined with an informal atmosphere of living home, confirming the timeless appeal and style of Casamilano collection.

Artigianalità e lavorazione

La collezione Casamilano è prodotta al 100% in Italia, dal design alla creatività, dallo stile alla realizzazione del prodotto finito. Nel pieno rispetto dell'ambiente, l'intero processo produttivo è eseguito da artigiani altamente qualificati, con una grande abilità e competenza, per garantire una qualità superiore.

Casamilano custom-made mette al servizio del Cliente la propria esperienza progettuale e produttiva, per la realizzazione di prodotti esclusivi e personalizzati per dimensioni, finiture e scelta dei materiali, oltre alla propria competenza nella realizzazione di progetti speciali residenziali di lusso e per il contract.

Crafting and workmanship. Casamilano collection is 100% made and manufactured in Italy, from the design to the creativity, from the style to the finished product. In full respect of the environment, the entire production process is carried out by highly skilled craftsmen, having a great ability and know-how, to ensure a superior quality.

Casamilano custom-made division offers to Clients its own experience in design and production, for the realization of exclusive products, which can be customized for sizes, finishes and choice of materials, in addition to its expertise in the implementation of special luxury residential projects and in contract.

SOFA



city modular sofa
with arne low and small table, andromeda suspension lamp



city modular sofa



city modular sofa
with shard wall lamp



city modular sofa
with rocco low table



city modular sofa



city modular sofa



suite modular sofa

with arne armchair, aldo low table, andromeda suspension lamp, duprè small table



suite modular sofa



suite modular sofa



pilopipe modular sofa
with liz armchair, arne low and small table



pillopipe modular sofa
with klee bookshelf, magenta armchair, vendome lamp



pillopipe modular sofa





pillopipe modular sofa



pillopipe modular sofa
with liz armchair, dupré small table





hamptons/18 modular sofa
with lea armchair, aldó low table, sign wall lamp



hamptons/18 modular sofa





hamptons/18 modular sofa
with aldo low table, sign wall lamp

A modern living room with a minimalist aesthetic. The focal point is a modular sofa with light-colored leather upholstery and dark piping. To the left, a chair with a dark frame and textured fabric is partially visible. A large, dark-framed mirror is mounted on the wall behind the sofa. To the right, a floor lamp with a rectangular shade and a dark frame stands next to a small, dark, round coffee table. The background wall is composed of large, dark panels, and a window with three vertical panes is visible. The floor is covered in a light-colored, textured rug. The overall lighting is soft and ambient, with a warm glow from the lamp.

hamptons/18 modular sofa
with reverso mirror, duprè small table, jackie lamp



hamptons/18 modular sofa
with arne armchair, reverso mirror, aldo low table



plaza sofa



plaza sofa
with viola xl lamp



royale sofa
with baby royale armchair



royale capitonné sofa





arne love-seat
with berlino small table, reverso mirror



arne love-seat





francesca love-seat
with jackie lamp



$20x \quad x+1=9$
 $\frac{5}{40}$
 $xx+1$
 $3x=$
 $\frac{421}{5-1=2}$
 $\frac{1}{2}$
 $\frac{18}{1x}$
 $20+1=22$
 $2x-4=$
 $\frac{21}{4921}$
 $34x:8=$
 $\frac{516}{41} \quad \frac{2x4}{}$
 $6x$
 $\frac{8}{4x}$
 $680x$
 $\frac{40}{4921}$

ARMCHAIR



ada armchair





ada armchair



carmen armchair





carmen armchair
with arne small table





liz armchair



liz armchair





lea armchair



baby royale armchair





royale armchair



dhora armchair





magenta armchair





magenta armchair





arne armchair
with sign wall lamp, aldo low table





arne armchair
with sign wall lamp





arne armchair





nana armchair





sophie armchair



big xl armchair





chloe small armchair
with atlante small table, shard wall lamp

OTTOMAN



tabouret ottoman



petite lea ottoman



hyatt ottoman

SMALL TABLE



dupré small table





dupré small table





mondrian small table





atlante small table





berlino small table





lugano small table
with jackie lamp





bollywood small table



bollywood bronze small table



arne small table





cartesio small table

LOW TABLE



cartesio low table



arne low and small table
"special edition"



arne low table





arne low and small table





arne low and small table



aldo low table



aldo low table





duprè low table





accademia low table



accademia low table
with elettra bronze lamp



mondrian low table



rocco low table





bryant low table

CABINET



mondrian/17 bookshelf
"special edition"



mondrian/17 bookshelf





mondrian/17 bookshelf



klee bookshelf





orlando/17
with madison handle





wright handle



madison handle

orlando /17





garbo sideboard
with viola xl lamp, lea armchair



garbo sideboard
with viola xl lamp, lea armchair



arne cabinet
with reverso mirror



arne cabinet
with reverso mirror, elettra bronze lamp



arne cabinet
with reverso mirror



mondrian shelf / TV



CHAIR



kelly chair





kelly chair





brigitte chair





brigitte chair



elsa chair
with sign wall lamp



elsa chair





royale chair





royale chair





diana chair



arne chair



arne chair



quadra chair





costanza chair



magenta chair

TABLE



arne table

with arne cabinet, arne chair, sign wall lamp



arne table
with arne chair



arne table
with brigitte chair



arne table
with arne chair, andromeda suspension lamp



arne table

with kelly chair, shard wall lamp



arne table

with elsa chair, reverso mirror, andromeda suspension lamp



kandinsky table

with royale chair, andromeda suspension lamp



kandinsky table





kandinsky table
with elsa chair, sign wall lamp



kandinsky table
with kelly chair, arne chair



bridge table



bridge table



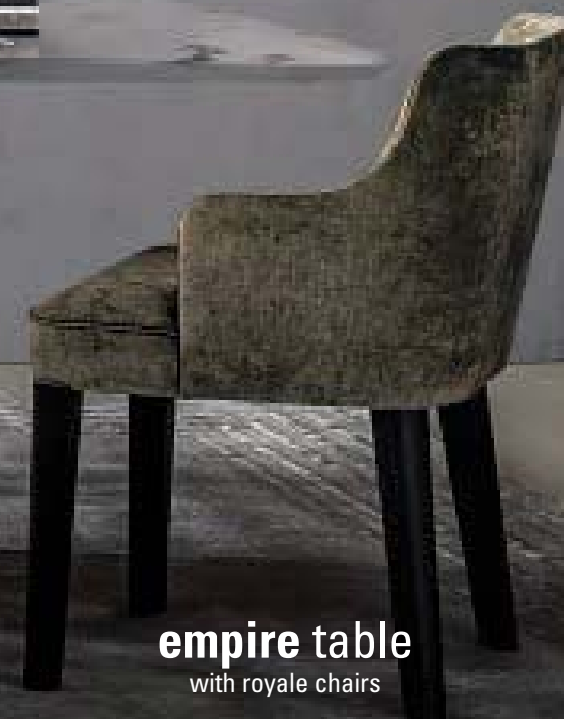

empire table
with royale chairs



empire table



DESK / CONSOLE



atlante console



ernest desk
with viola lamp

LAMP



shard wall lamps





shard suspension lamp





andromeda suspension lamp





sign wall lamp





vendome lamp



viola lamp



elettra bronze lamp



viola xl lamp



jackie lamp

MIRROR



carrè mirror



specchio mirror





vittoria mirrors





reverso mirror



BED



majestic bed
with dupré small table



majestic bed





westin bed





westin bed



astoria bed

with dupré small table, shard wall lamp



astoria bed





vanity bed



vanity bed





royale capitonné bed



royale bed



royale bed



pillopipe bed



jacopo bed



Colore filo ricamo / Embroidery thread colour / Fadenfarbe des Stickens / Couleur fil brodé

only for Plaza sofa, Liz armchair



Colore filo cod. 5400 beige
Thread colour cod. 5400 beige
Fadenfarbe Cod. 5400 Beige
Fil couleur cod. 5400 beige



Colore filo cod. 5400 beige
Thread colour cod. 5400 beige
Fadenfarbe Cod. 5400 Beige
Fil couleur cod. 5400 beige



Colore filo cod. 5400 beige
Thread colour cod. 5400 beige
Fadenfarbe Cod. 5400 Beige
Fil couleur cod. 5400 beige



Colore filo cod. 5400 beige
Thread colour cod. 5400 beige
Fadenfarbe Cod. 5400 Beige
Fil couleur cod. 5400 beige



Colore filo cod. 906 grigio
Thread colour cod. 906 grey
Fadenfarbe Cod. 906 Grau
Fil couleur cod. 906 gris



Colore filo cod. 906 grigio
Thread colour cod. 906 grey
Fadenfarbe Cod. 906 Grau
Fil couleur cod. 906 gris

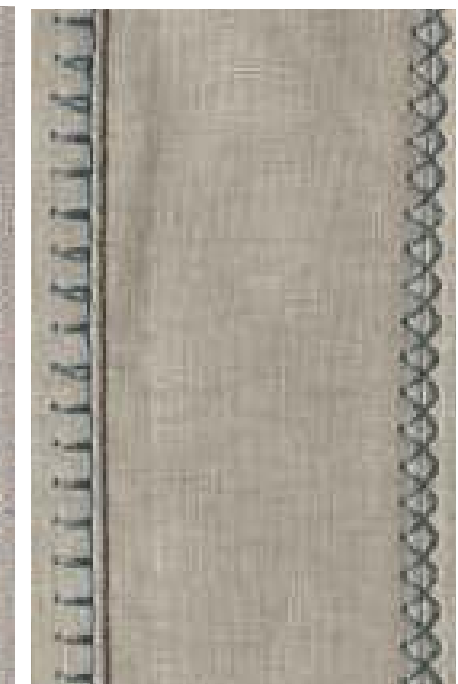

Colore filo cod. 906 grigio
Thread colour cod. 906 grey
Fadenfarbe Cod. 906 Grau
Fil couleur cod. 906 gris



Colore filo cod. 906 grigio
Thread colour cod. 906 grey
Fadenfarbe Cod. 906 Grau
Fil couleur cod. 906 gris

technical info / finishes

Casamilano si riserva di apportare, senza preavviso, modifiche nei materiali, nei rivestimenti, nelle finiture e nei disegni dei prodotti presentati in questo catalogo. Le texture, i colori dei materiali e delle finiture hanno valore indicativo in quanto soggetti alle tolleranze dei processi di stampa.

Casamilano reserves the right to make changes to the materials, upholstery, finishes and designs of the products shown in this catalogue without notice. The textures and colours of the materials and finishes are merely approximate, being subject to printing process tolerances.

Casamilano behält sich das Recht vor, ohne Vorankündigung Änderungen an den Werkstoffen, Bezügen, Ausführungen und dem design der im Katalog aufgeführten Produkte anzubringen. Die Texturen sowie Farben von Werkstoffen und Ausführungen wurden im Druckverfahren hergestellt. Geringe Unterschiede zu den Original-Materialien sind daher möglich.

Casamilano se réserve le droit d'apporter, sans avis préalable, des modifications aux matériaux, aux revêtements, aux finitions et aux dessins des produits présentés dans ce catalogue. Les textures, les couleurs des matériaux et des finitions ont une valeur indicative, car elles sont soumises aux tolérances des procédés d'impression.

Cartesio / design Pietro Russo

Cartesio / design Pietro Russo

Tavolino / tavolo basso in acciaio spazzolato, finitura gold.

cm. Ø 40 x h. 50
cm. Ø 110 x h. 20
cm. l. 120 x p. 80 x h. 20



Small table / low table, brushed steel, gold finish.

cm. Ø 40 x h. 50
cm. Ø 110 x h. 20
cm. l. 120 x p. 80 x h. 20



Kleintisch / Beistelltisch aus gebürstetem Stahl, Gold Ausführung.

cm. Ø 40 x h. 50
cm. Ø 110 x h. 20
cm. l. 120 x p. 80 x h. 20



Petite table / table basse en acier brossé, finition gold.

cm. Ø 40 x h. 50
cm. Ø 110 x h. 20
cm. l. 120 x p. 80 x h. 20

Sottsass Grey - special edition

Mondrian special edition / design Massimiliano Raggi

Libreria, struttura finitura color platino. Ripiani in legno naturale. Pattern design Ettore Sottsass, caratterizzato dall'accentuazione del disegno delle venature. Tranciato multilaminare decorativo composto da pioppo, ayous, tiglio.

cm. l.125 x p.39 x h.220



Bookshelf, structure platino colour. Shelves in natural wood. Pattern, design Ettore Sottsass, characterized by the accentuation of the veins. Decorative multilaminar wood veneer composed of poplar, ayous, basswood.

cm. l.125 x p.39 x h.220



Bibliothek, Struktur: Platino Farbe. Regale:aus Naturholz. Durch die Akzentuierung des Kornmusters gekennzeichnete Musterung, design Ettore Sottsass.Dekoratives Multilaminar-Furnier bestehend aus: Pappel, Ayous, Linde.

cm. l.125 x p.39 x h.220

Bibliothèque, structure finition couleur platino. Etagères en bois naturel. Motif design Ettore Sottsass, caractérisé par l'accentuation des veines. Placage multilaminaire décoratif composé par peuplier, ayous, tilleul.

cm. l.125 x p.39 x h.220

Arne special edition / design Roberto Lazzeroni

Tavolo basso / tavolino con piano in legno naturale. Pattern design Ettore Sottsass, caratterizzato dall'accentuazione del disegno delle venature. Tranciato multilaminare decorativo composto da pioppo, ayous, tiglio.

cm Ø 40 x H. 50
cm Ø 90 x H. 35
cm Ø 120 x H. 35
cm. l.140 x p.70 x H. 35 ovale



Low table / small table with natural wooden top. Pattern, design Ettore Sottsass, characterized by the accentuation of the veins. Decorative multilaminar wood veneer composed of poplar, ayous, basswood.

cm Ø 40 x H. 50
cm Ø 90 x H. 35
cm Ø 120 x H. 35
cm. l.140 x p.70 x H. 35 ovale



Beistelltisch / Kleintisch, Platte aus Naturholz. Durch die Akzentuierung des Kornmusters gekennzeichnete Musterung, design Ettore Sottsass. Dekoratives Multilaminar-Furnier bestehend aus: Pappel, Ayous, Linde.

cm Ø 40 x H. 50
cm Ø 90 x H. 35
cm Ø 120 x H. 35
cm. l.140 x p.70 x H. 35 ovale

Table basse / petite table avec plateau en bois naturel. Motif design Ettore Sottsass, caractérisé par l'accentuation des veines. Placage multilaminaire décoratif composé par peuplier, ayous, tilleul.

cm Ø 40 x H. 50
cm Ø 90 x H. 35
cm Ø 120 x H. 35
cm. l.140 x p.70 x H. 35 ovale

City / Design Paola Navone / pag.7, 9, 11, 13, 15, 17

Divano componibile, struttura in massello di abete. Imbottitura in poliuretano espanso a densità differenziata. Piedi ABS. Rivestimento sfoderabile (tessuto) / fisso (pelle).

Elementi terminali cm.l.110/130 x p. 90 x h. 38/76 (bracciolo H. cm. 53)
Elementi centrali cm l. 90/110 x p. 90 x h. 38/76
Corner cm l. 90x90
Chaise longue cm. l.110 x p.150x h. 38/76 (bracciolo H. cm. 53)
Penisola cm. l. 176 x p. 170 x h. 38/76

Modular sofa, structure in solid pinewood. Upholstered in different densities of polyurethane foam. ABS feet. Removable cover (fabric) / fixed cover (leather).

Element with 1 armrest cm.l.110/130 x p. 90 x h. 38/76 (armrest H. cm. 53)
Central element cm l. 90/110 x p. 90 x h. 38/76
Corner cm l. 90x90
Chaise longue cm. l. 110 x p. 150 x h. 38/76 (armrest H. cm. 53)
Open-end cm. l. 176 x p. 170 x h. 38/76

Anbausofa, Struktur aus massivem Tannenholz. Polsterung aus Polyurethanschaum mit differenzierter Dichte. FüÙe aus ABS. Abnehmbarer Bezug (Stoff) / Fester Bezug (Leder).

Endelement mit 1 Armlehne cm.l.110/130 x p. 90 x h. 38/76 (Armlehne H. cm. 53)
Mittelement cm l. 90/110 x p. 90 x h. 38/76
Corner cm l. 90x90
Eckelement cm l. 90x90
Chaise longue cm. l.110 x p. 150 x h. 38/76 (Armlehne H. cm. 53)
Halbinsel cm. l. 176 x p. 170 x h. 38/76

Canapé modulaire, structure en sapin massif. Rembourrage en mousse de polyuréthane à densité différenciée. Pieds en ABS. Revêtement: déhoussable (tissu) / non déhoussable (cuir).

Élément avec 1 accoudoir cm.l.110/130 x p. 90 x h. 38/76 (accoudoir H. cm. 53)
Élément central cm l. 90/110 x p. 90 x h. 38/76
Élément d'angle cm l. 90x90
Chaise longue cm. l. 110 x p. 150 x h. 38/76 (accoudoir H. cm. 53)
Ilot cm. l. 176 x p. 170 x h. 38/76

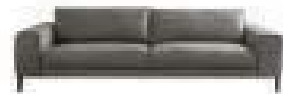

Hamptons/18 / Design Castello Lagravinese / pag. 35, 37, 39, 41, 43

Divano componibile, struttura in massello di abete, multistrato di pioppo e pannelli in particelle di legno. Imbottitura in poliuretano espanso a densità differenziata. Cuscini schienale in piuma d'oca e rollofill. Cuscini seduta, inserto centrale in poliuretano espanso ad alta densità. Piedi H.15 in massello di faggio tinto ebano. Rivestimento sfoderabile (tessuto) / fisso (pelle).

Divani cm l. 230 / 270 x p. 110 x h. 42 / 62
Elementi terminali cm l. 205 / 245 x p. 110 x h. 42 / 62
Elementi centrali cm l. 180 / 220 x p. 110 x h. 42 / 62
Penisola cm l. 160 x p. 160 x h. 42 / 62
Chaise longue cm l. 115 x p. 160 / 250 x h. 42 / 62

Modular sofa, frame in solid pinewood, multi ply of poplar and wooden particleboard panel. Upholstered in different densities of polyurethane foam. Back cushions in goose down and rollofill. Seat cushions, central insert in polyurethane foam with high density. Feet H.15 in solid beech wood, ebony colour. Removable cover (fabric) / fixed cover (leather).

Sofas cm l. 230 / 270 x p. 110 x h. 42 / 62
Element with 1 armrest cm l. 205 / 245 x p. 110 x h. 42 / 62
Central element cm l. 180 / 220 x p. 110 x h. 42 / 62
Open-end cm l. 160 x p. 160 x h. 42 / 62
Chaise longue cm l. 115 x p. 160 / 250 x h. 42 / 62

Anbausofa, Struktur aus massivem Tannenholz, Pappelmultiplexplatte und Spanplattenholz. Polsterung aus Polyurethanschaum mit differenzierter Dichte. Rückenkissen aus Daunen und Rollofill. Sitzkissen: Zentraleinsatz aus Polyurethanschaum mit hoher Dichte. Massive BuchenholzfüÙe H. 15 Ebenfarbe. Abziehbarer Bezug (Stoff) / Fester Bezug (Leder).

Sofa cm l. 230 / 270 x p. 110 x h. 42 / 62
Endelement mit 1 Armlehne cm l. 205 / 245 x p. 110 x h. 42 / 62
Mittelement cm l. 180 / 220 x p. 110 x h. 42 / 62
Halbinsel cm l. 160 x p. 160 x h. 42 / 62
Chaise longue cm l. 115 x p. 160 / 250 x h. 42 / 62

Canapé modulaire, structure en sapin massif, multiplis de peuplier et panneau de particules de bois. Rembourrage: mousse polyuréthane à densité différenciée. Coussins de dos en plume d'oie et rollofill. Coussins d'assise avec insert central en mousse de polyuréthane à haute densité. Pieds en hêtre massif H. 15, ton èbène. Revêtement déhoussable (tissu) / non déhoussable (cuir).

Canapés cm l. 230 / 270 x p. 110 x h. 42 / 62
Élément avec 1 accoudoir cm l. 205 / 245 x p. 110 x h. 42 / 62
Élément central cm l. 180 / 220 x p. 110 x h. 42 / 62
Ilot cm l. 160 x p. 160 x h. 42 / 62
Chaise longue cm l. 115 x p. 160 / 250 x h. 42 / 62

Suite / Design Paola Navone / pag. 19, 21, 23

Divano componibile, struttura in massello di abete, multistrato di pioppo e pannelli in particelle di legno. Imbottitura in poliuretano espanso a densità differenziata. Cuscini seduta e schienale in piuma d'oca canalizzata con inserto in poliuretano espanso a densità differenziata. Piedi in ABS. Rivestimento sfoderabile (tessuto) / fisso (pelle).

Divani cm. l. 228/268/320 x p.102/122 x h.38/80
Elementi terminali cm l.114/134/206/246/298 x p.102/122 x h.38/80
Elementi centrali cm l. 92/112/184/224/276 x p.102/122 x h.38/80
Corner cm l. 102 /122 x p. 102/122 x h.38/80
Chaise longue cm l. 114/134 x p.150 x h.38/80
Pouff cm l. 122 x p.102 x h.38, l. 92 x p.50 x h.38, l. 112 x p.50 x h.38

Modular sofa, frame in solid pinewood, multi ply of poplar and wooden particleboard panel. Upholstered in different densities of polyurethane foam. Cushions for seat and back: canalized goose feathers, with an insert in different densities of polyurethane foam. ABS feet. Removable cover (fabric) / fixed cover (leather).

Sofa cm. l. 228/268/320 x p.102/122 x h.38/80
Element with 1 armrest cm l. 114/134/206/246/298 x p.102/122 x h.38/80
Central element cm l. 92/112/184/224/276 x p.102/122 x h.38/80
Corner cm l. 102 /122 x p. 102/122 x h.38/80
Chaise longue cm l. 114/134 x p.150 x h.38/80
Ottoman cm l. 122 x p.102 x h.38, l. 92 x p.50 x h.38, l. 112 x p.50 x h.38

Anbausofa, Struktur aus massivem Tannenholz, Pappelmultiplexplatte und Spanplattenholz. Polsterung aus Polyurethanschaum mit differenzierter Dichte. Kissen für Sitz und Rückenlehne: Kanalisierte Gänsefedern mit Einsatz aus Polyurethanschaum mit differenzierter Dichte. FüÙe: aus ABS. Abziehbarer Bezug (Stoff) / Fester Bezug (Leder).

Sofa cm. l. 228/268/320 x p.102/122 x h.38/80
Endelement mit 1 Armlehne cm l. 114/134/206/246/298 x p.102/122 x h.38/80
Mittelement cm l. 92/112/184/224/276 x p.102/122 x h.38/80
Eckelement cm l. 102 /122 x p. 102/122 x h.38/80
Chaise longue cm l. 114/134 x p.150 x h.38/80
Hocker cm l. 122 x p.102 x h.38, l. 92 x p.50 x h.38, l. 112 x p.50 x h.38

Canapé modulaire, structure en sapin massif, multiplis de peuplier et panneau de particules de bois. Rembourrage: mousse polyuréthane à densité différenciée. Coussins de dos et d'assise réalisés en plumes d'oie canalisées, avec insert en mousse polyuréthane expansé à densité différenciée. Pieds en ABS. Revêtement déhoussable (tissu) / non déhoussable (cuir).

Canapé cm. l. 228/268/320 x p.102/122 x h.38/80
Élément avec 1 accoudoir cm l. 114/134/206/246/298 x p.102/122 x h.38/80
Élément central cm l. 92/112/184/224/276 x p.102/122 x h.38/80
Élément d'angle cm l. 102 /122 x p. 102/122 x h.38/80
Chaise longue cm l. 114/134 x p.150 x h.38/80
Pouf cm l. 122 x p.102 x h.38, l. 92 x p.50 x h.38, l. 112 x p.50 x h.38



Plaza / Design Paola Navone / pag. 45, 47

Divano componibile, struttura in massello di abete, multistrato di pioppo e pannelli in particelle di legno. Imbottitura in poliuretano espanso a densità differenziata. Cuscini seduta: piuma d'oca canalizzata e poliuretano espanso ad alta densità. Cuscini schienale in piuma d'oca. Piedi in ABS. Rivestimento sfoderabile (tessuto) / fisso (pelle). Confezione standard con profilo in tinta. Varianti: cuciture ricamate + versione con borchie (rivestimento fisso).

Divani cm. l. 252/328 x p.95 x h.42/80
Elementi terminali cm l. 164/233 x p.95 x h.42/80
Corner cm l. 95 x p.95 x h.42/80
Chaise longue cm l. 90 x p.150 x h.42/80

Modular sofa, frame in solid pinewood, multi ply of poplar and wooden particleboard panel. Upholstered in different densities of polyurethane foam. Seat cushions: canalized goose feather and high-density polyurethane foam. Back cushions in goose feather. ABS feet. Removable cover (fabric) / fixed cover (leather). Standard cover with profile matching. Versions: embroidered stitching + model with studs (fixed cover).

Sofa cm. l. 252/328 x p.95 x h.42/80
Element with 1 armrest cm l. 164/233 x p.95 x h.42/80
Corner cm l. 95 x p.95 x h.42/80
Chaise longue cm l. 90 x p.150 x h.42/80

Anbausofa, Struktur aus massivem Tannenholz, Pappelmultiplexplatte und Spanplattenholz. Polsterung aus Polyurethanschaum mit differenzierter Dichte. Sitzkissen: kanalisiertes Gänsefedern und hochdichtem PUR-Schaum. Rücken kissen vollständig aus Gänsefedern. FüÙe aus ABS. Abziehbarer Bezug (Stoff) / Fester Bezug (Leder). Standardanfertigung mit Keder in derselben Farbe. Version: bestickte Nähte + Modell mit Nieten (Fester Bezug).

Sofa cm. l. 252/328 x p.95 x h.42/80
Endelement mit 1 Armlehne cm l. 164/233 x p.95 x h.42/80
Eckelement cm l. 95 x p.95 x h.42/80
Chaise longue cm l. 90 x p.150 x h.42/80

Canapé modulaire, structure en sapin massif, multiplis de peuplier et panneau de particules de bois. Rembourrage: mousse polyuréthane à densité différenciée, Coussins d'assise: plumes d'oie canalisées et mousse polyuréthane haute densité. Coussins dossier entièrement en plumes d'oie. Pieds en ABS. Revêtement déhoussable (tissu) / non déhoussable (cuir). Revêtement standard bordé en teinte. Variante : coutures brodées + modèle avec clous (revêtement non déhoussable).

Canapé cm. l. 252/328 x p.95 x h.42/80
Élément avec 1 accoudoir cm l. 164/233 x p.95 x h.42/80
Élément d'angle cm l. 95 x p.95 x h.42/80
Chaise longue cm l. 90 x p.150 x h.42/80

Pilopipe / Design Paola Navone / pag. 25, 27, 29, 31, 33

Divano componibile, struttura in massello di abete, multistrato di pioppo e pannelli in particelle di legno. Schienale in multistrato di betulla elasticizzato. Imbottitura in poliuretano espanso a densità differenziata. Cuscini seduta in piuma d'oca canalizzata (o in poliuretano espanso, su richiesta) con inserto centrale in poliuretano espanso ad alta densità, completamente reversibili. Cuscini schienale: in piuma d'oca. Piedi in ABS. Rivestimento sfoderabile (tessuto) / fisso (pelle).

Divani cm. l. 200/240/ 293 x p.104 x h.38/63
Elementi terminali cm l. 102/146/186/226/279 / Penisola cm. l.160 x p.104 x h.38/63,
Elementi centrali cm. l. 132/172/212 x p. 104 x h. 38/63
Corner cm l. 104 x p.104 x h.38/63
Chaise longue cm l. 104 x p.160 x h.38/63
Pouff cm l. 86/106 x p.78 x h.38

Modular sofa, frame in solid pinewood, multi ply of poplar and wooden particleboard panel. Back in elasticized multi ply of birch wood. Upholstered in different densities of polyurethane foam. Seat cushions in canalized goose feather (or polyurethane foam on demand) with central insert in high-density polyurethane foam, fully reversible. Backrest cushions in goose feathers. ABS feet. Removable cover (fabric) / fixed cover (leather).

Sofa cm. l. 200/240/ 293 x p.104 x h.38/63
Element with 1 armrest cm l. 102/146/186/226/279 x p.104 x h.38/63
Open-end cm l. 160 x p. 104x h. 38/63,
Central elements cm l.132/172/212 x p. 104 x h. 38/63
Corner cm l. 104 x p.104 x h.38/63
Chaise longue cm l. 104 x p.160 x h.38/63
Ottoman cm l. 86/106 x p.78 x h.38

Anbausofa, Struktur aus massivem Tannenholz, Pappelmultiplexplatte und Spanplattenholz. Rückenlehne aus dehnbaren Birken multiplexplatte. Polsterung aus Polyurethanschaum mit differenzierter Dichte. Sitzkissen aus kanalisiertes Gänsefedern (oder Pur Schaum, auf Anfrage) Beidseitig verwendbar, mit mittlerem Einsatz aus hochdichtem Pur-Schaum. Rücken kissen: Gänsefedern. FüÙe aus ABS. Abziehbarer Bezug (Stoff) / Fester Bezug (Leder).

Sofa cm. l. 200/240/ 293 x p.104 x h.38/63
Endelement mit 1 Armlehne cm l. 102/146/186/226/279 x p.104 x h.38/63
Halbinsel cm. l.160 x p.104 x h.38/63,
Mittelement cm. l. 132/172/212 x p. 104 x h. 38/63
Eckelement cm l. 104 x p.104 x h.38/63
Chaise longue cm l. 104 x p.160 x h.38/63
Hocker cm l. 86/106 x p.78 x h.38

Canapé modulaire, structure en sapin massif, multiplis de peuplier et panneau de particules de bois. Dossier en multicouche de bouleau élastique. Rembourrage en mousse polyuréthane à densité différenciée. Coussins d'assise en plumes d'oie canalisées (ou polyuréthane sur requête) complètement réversibles, avec insert central en mousse polyuréthane à haute densité. Coussins de dos en plumes d'oie. Pieds en ABS. Revêtement déhoussable (tissu) / non déhoussable (cuir).

Canapé cm. l. 200/240/ 293 x p.104 x h.38/63
Élément avec 1 accoudoir l.cm l. 102/146/186/226/279 x p.104 x h.38/63
Ilot cm l. 160 x p. 104x h. 38/63,
Élément central cm. l.132/172/212 x p. 104 x h. 38/63
Élément d'angle cm l. 104 x p.104 x h.38/63
Chaise longue cm l. 104 x p.160 x h.38/63
Pouf cm l. 86/106 x p.78 x h.38



Royale / Design Castello Lagravinese / pag. 49, 51

Divano, struttura in massello di abete/ pioppo e multistrato di abete. Imbottitura in poliuretano espanso a densità differenziata. Piedi in ABS. Rivestimento fisso.

cm. l. 250/300 x p.102 x h.42/82

Sofa, solid pinewood, poplar and multi ply of pinewood. Upholstered in different densities of polyurethane foam. ABS feet. Fixed cover.

cm. l. 250/300 x p.102 x h.42/82

Sofa, Struktur aus massivem Tannenholz, Pappelholz und Tannenholzmultiplexplatte. Polsterung aus Polyurethanschaum mit differenzierter Dichte. FüÙe aus ABS. Fester Bezug.

cm. l. 250/300 x p.102 x h.42/82

Canapé, structure en sapin et peuplier massif, multiplis de sapin. Rembourrage mousse polyuréthane à densité différenciée. Pieds en ABS. Revêtement non déhoussable.

cm. l. 250/300 x p.102 x h.42/82

Arne / Design Roberto Lazzeroni / pag. 53, 55

Divano, struttura in massello, multistrato e compensato di pioppo. Imbottitura in poliuretano espanso a densità differenziata. Basamento in massello di faggio tinto ebano. Rivestimento fisso.

cm l. 182 x p. 87 x h. 40 / 82

Sofa, structure in solid, multi ply and plywood of poplar. Upholstered in different densities of polyurethane foam. Base in solid beech wood, ebony colour. Fixed cover.

cm l. 182 x p. 87 x h. 40 / 82

Sofa, Struktur aus massivem Pappelholz, Multiplexplatte und Sperrpappelholz. Polsterung aus Polyurethanschaum mit differenzierter Dichte. Massives Buchenholzgestell "Ebenholz" Farbe. Fester Bezug.

cm l. 182 x p. 87 x h. 40 / 82

Canapé, structure en peuplier massif, multiplis et contreplaqué de peuplier. Rembourrage en mousse de polyuréthane à densité différenciée. Base en hêtre massif, ton èbène. Revêtement non déhoussable.

cm l. 182 x p. 87 x h. 40 / 82

Francesca / Design Roberto Lazzeroni / pag. 57

Divanetto, struttura in massello di abete e multistrato flessibile (multiflex). Imbottitura in poliuretano espanso a densità differenziata. Piedi in ABS. Rivestimento sfoderabile (tessuto) / fisso (pelle).

cm. l.150 x p.120 x h.38/69

Love-seat, solid pinewood and flexible multi ply (multiflex). Upholstered in different densities of polyurethane foam. ABS feet. Removable cover (fabric) / fixed cover (leather).

cm. l.150 x p.120 x h.38/69

Love-Seat. Struktur aus massivem Tannenholz und Multiplexplatte (Multiflex). Polsterung aus Polyurethanschaum mit differenzierter Dichte. FüÙe aus ABS. Abziehbarer Bezug (Stoff) / Fester Bezug (Leder).

cm. l.150 x p.120 x h.38/69

Love-seat, structure en sapin massif, multiplis flexible (multiflex). Rembourrage mousse polyuréthane à densité différenciée. Pieds en ABS. Revêtement déhoussable (tissu) / non déhoussable (cuir).

cm. l.150 x p.120 x h.38/69

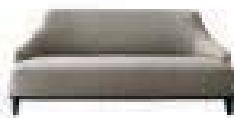

Ada / Design Paola Navone / pag. 61, 63

Poltrona, struttura in multistrato di pioppo e betulla. Imbottitura in poliuretano espanso a densità differenziata. Piedi in ABS. Rivestimento sfoderabile (tessuto) / fisso (pelle).

cm. l. 66 x p. 58 x h. 40/71

Armchair, structure in multi ply of poplar and birch wood. Upholstered in different densities of polyurethane foam. ABS feet. Removable cover (fabric) / fixed cover (leather).

cm. l. 66 x p. 58 x h. 40/71

Sessel, Struktur aus massivem Tannenholz und Pappelmultiplexplatte. Polsterung aus Polyurethanschaum mit differenzierter Dichte. Füße aus ABS. Abnehmbarer Bezug (Stoff) / Fester Bezug (Leder).

cm. l. 66 x p. 58 x h. 40/71

Fauteuil, structure en sapin massif et multiplis de peuplier. Rembourrage en mousse de polyuréthane à densité différenciée. Pieds en ABS. Revêtement: déhoussable (tissu) / non déhoussable (cuir).

cm. l. 66 x p. 58 x h. 40/71

Carmen / Design Paola Navone / pag. 65, 67

Poltrona, struttura in massello di abete e multistrato di pioppo. Imbottitura in poliuretano espanso a densità differenziata. Piedi in ABS. Rivestimento sfoderabile (tessuto) / fisso (pelle).

cm. l. 55 x p. 60 x h. 40 / 93

Armchair, structure in solid pinewood and multi ply of poplar. Upholstered in different densities of polyurethane foam. ABS feet. Removable cover (fabric) / fixed cover (leather).

cm. l. 55 x p. 60 x h. 40 / 93

Sessel, Struktur aus massivem Tannenholz und Pappelmultiplexplatte. Polsterung aus Polyurethanschaum mit differenzierter Dichte. Füße aus ABS. Abnehmbarer Bezug (Stoff) / Fester Bezug (Leder).

cm. l. 55 x p. 60 x h. 40 / 93

Fauteuil, structure en sapin massif et multiplis de peuplier. Rembourrage en mousse de polyuréthane à densité différenciée. Pieds en ABS. Revêtement: déhoussable (tissu) / non déhoussable (cuir).

cm. l. 55 x p. 60 x h. 40 / 93

Liz / Design Roberto Lazzeroni / pag. 24, 33, 69, 71

Poltrona, struttura in multistrato di abete e pannelli in particelle di legno. Imbottitura in poliuretano espanso a densità differenziata. Piedi in massello di faggio tinto ebano. Cuciture ricamate. Rivestimento sfoderabile (tessuto) / fisso (pelle).

cm. l. 68 x p.80 x h.42/81

Armchair, frame in multi ply of pinewood and particleboard wooden panel. Upholstered in different densities of polyurethane foam. Feet in solid beech wood, ebony colour. Embroidered stitching. Removable cover (fabric) / fixed cover (leather).

cm. l. 68 x p.80 x h.42/81

Sessel, Struktur aus Tannenmultiplexplatten und Spanplatte. Polsterung aus Polyurethanschaum mit differenzierter Dichte. Massive Buchenholz Füße, Ebenfarbe. Bestickte Nähte. Abnehmbarer Bezug (Stoff) / Fester Bezug (Leder).

cm. l. 68 x p.80 x h.42/81

Fauteuil, structure en multiplis de sapin et panneau de particules de bois. Rembourrage en mousse de polyuréthane à densités différenciées. Pieds en hêtre massif, ton ébène. Coutures brodées. Revêtement déhoussable (tissu) / non déhoussable (cuir).

cm. l. 68 x p.80 x h.42/81

Lea / Design Paola Navone / pag. 34, 73

Poltroncina, struttura in poliuretano flessibile. Autoestingente. Inserto in acciaio. Rivestimento sfoderabile (tessuto) / fisso (pelle).

cm. l.57 x p.60 x h.35/70

Small armchair, flexible polyurethane structure. Self-extinguishing. Steel insert. Removable cover (fabric) / fixed cover (leather).

cm. l.57 x p.60 x h.35/70

Kleiner Sessel, Struktur aus flexiblem Polyurethan. Selbstverlöschend. Staheinsatz. Abnehmbarer Bezug (Stoff) / Fester Bezug (Leder).

cm. l.57 x p.60 x h.35/70

Petit fauteuil, structure en polyuréthane flexible. Autoextinguible. Insert en acier. Revêtement déhoussable (tissu) / non déhoussable (cuir).

cm. l.57 x p.60 x h.35/70

Baby Royale - Royale / Design Castello Lagravinese / pag. 75, 77

Poltrona, struttura in massello di abete/pioppo e multistrato di abete. Imbottitura in poliuretano espanso a densità differenziata. Piedi in ABS. Rivestimento sfoderabile (tessuto) / fisso (pelle).

Baby Royale
cm l.77 x p.83 x h.40/81,5
Royale
cm. l.100 x p.92 x h.42/82

Armchair, structure in solid pinewood / poplar and multi ply of pinewood. Upholstered in different densities of polyurethane foam. ABS feet. Removable cover (fabric) / fixed cover (leather).

Baby Royale
cm l.77 x p.83 x h.40/81,5
Royale
cm. l.100 x p.92 x h.42/82

Sessel, Struktur aus Massivtannenholz / Pappelholz und Tannenmultiplexplatte. Polsterung aus Polyurethanschaum mit differenzierter Dichte. Füße: aus ABS. Abnehmbarer Bezug (Stoff) / Fester Bezug (Leder).

Baby Royale
cm l.77 x p.83 x h.40/81,5
Royale
cm. l.100 x p.92 x h.42/82

Fauteuil, structure en sapin massif / peuplier et multiplis de sapin. Rembourrage en mousse de polyuréthane à densités différentes. Pieds en ABS. Revêtement déhoussable (tissu) / non déhoussable (cuir).

Baby Royale
cm l.77 x p.83 x h.40/81,5
Royale
cm. l.100 x p.92 x h.42/82

Dhora / Design Massimiliano Raggi / pag. 79

Poltrona, struttura in multistrato di pioppo e lamiera microforata (schienale). Imbottitura in poliuretano espanso a densità differenziata. Basamento in massello di faggio tinto ebano e MDF laccato. Rivestimento sfoderabile (tessuto) / fisso (pelle).

cm. l. 76 x p.88 x h.40/75

Armchair, frame in multi ply of poplar and micro-perforated sheet metal (back). Upholstered in different densities of polyurethane foam. Base in solid beech wood, ebony colour and lacquered MDF. Removable cover (fabric) / fixed cover (leather).

cm. l. 76 x p.88 x h.40/75

Sessel, Struktur aus Pappelmultiplexplatte und mikrogelochten Folienabsorber (Rücklehne). Polsterung aus Polyurethanschaum mit differenzierter Dichte. Basis: aus gefärbtem massivem Buchenholz und lackiertem MDF, Ebenfarbe. Abnehmbarer Bezug (Stoff) / Fester Bezug (Leder).

cm. l. 76 x p.88 x h.40/75

Fauteuil, structure en multiplis de peuplier et tôle micro perforée (dossier). Rembourrage en mousse polyuréthane à densité différenciée. Base en hêtre massif et MDF laqué, ton ébène. Revêtement déhoussable (tissu) / non déhoussable (cuir).

cm. l. 76 x p.88 x h.40/75

Magenta / Design Castello Lagravinese / pag. 26, 81, 83

Poltrona / bergère / appoggiatepiedi, struttura in massello di abete e multistrato di betulla. Imbottitura in poliuretano espanso a densità differenziata. Piedi in massello di faggio tinto ebano. Rivestimento sfoderabile (tessuto) / fisso (pelle).

Poltrona cm. l. 70 x p.84 x h.38/80
Bergère cm. l.70 x p.90 x h.38/100
Pouff cm. l. 70 x p.45 x h.38

Armchair / bergère / ottoman. Solid pinewood structure, multi ply of birch wood. Upholstered in different densities of polyurethane foam. Feet in solid beech wood, ebony colour. Removable cover (fabric) / fixed cover (leather).

Armchair cm. l. 70 x p.84 x h.38/80
Bergère cm. l.70 x p.90 x h.38/100
Ottoman cm. l. 70 x p.45 x h.38

Sessel / Bergère / Hocker. Struktur aus Massivtannenholz und Multischicht Birke. Polsterung aus Polyurethanschaum mit differenzierter Dichte. Massive Buchenholzfüße, Ebenfarbe. Abnehmbarer Bezug (Stoff) / Fester Bezug (Leder).

Sessel cm. l. 70 x p.84 x h.38/80
Bergère cm. l.70 x p.90 x h.38/100
Hocker cm. l. 70 x p.45 x h.38

Fauteuil / bergère / pouf. Structure en sapin massif et multiplis de bouleau. Rembourrage mousse polyuréthane à densité différenciée. Pieds en hêtre massif, ton ébène. Revêtement déhoussable (tissu) / non déhoussable (cuir).

Fauteuil cm. l. 70 x p.84 x h.38/80
Bergère cm. l.70 x p.90 x h.38/100
Pouf cm. l. 70 x p.45 x h.38

Arne / Design Roberto Lazzeroni / pag. 18, 85, 87

Poltrona imbottita, struttura e schienale curvato in multistrato e compensato di pioppo. Imbottitura in poliuretano espanso a densità differenziata. Basamento in massello di faggio tinto ebano. Rivestimento fisso.

cm l. 89 x p. 90 x h. 40 / 82

Upholstered armchair, structure and back in bent multi ply and plywood of poplar wood. Upholstered in different densities of polyurethane foam. Base in solid beech wood, ebony colour. Fixed cover.

cm l. 89 x p. 90 x h. 40 / 82

Polstersessel, Struktur und gebogene Rücklehne aus Multiplexplatte und Pappelsperholz. Polsterung aus Polyurethanschaum mit differenzierter Dichte. Massives Buchenholzgestell "Ebenholz" Farbe. Fester Bezug.

cm l. 89 x p. 90 x h. 40 / 82

Fauteuil rembourré, structure et dos courbé en multiplis et contreplaqué de peuplier. Rembourrage en mousse de polyuréthane à densité différenciée. Base en hêtre massif, ton ébène. Revêtement non déhoussable.

cm l. 89 x p. 90 x h. 40 / 82

Arne / Design Roberto Lazzeroni / pag. 42, 89

Poltrona, struttura in massello di frassino tinto. Inserto seduta e schienale in multistrato curvato di pino. Imbottitura in poliuretano espanso a densità differenziata. Rivestimento seduta fisso, cuscino schienale sfoderabile.

cm l.70 x p.72,5 x h.40 / 73

Armchair, painted solid ash-wooden structure. Seat and back insert in bent multi ply of birch wood. Upholstered in different densities of polyurethane foam. Fixed cover for the seat, removable cover for the back cushion.

cm l.70 x p.72,5 x h.40 / 73

Polstersessel, Struktur aus Eschenholz. Sitzesatz und Rücklehne aus gebogenem Kiefer Multischicht. Polsterung aus Polyurethanschaum mit differenzierter Dichte. Fester Sitzbezug, abnehmbares Rückenissen.

cm l.70 x p.72,5 x h.40 / 73

Fauteuil, structure en frêne massif. Insert pour l'assise et le dos en contreplaqué courbé de pin. Rembourrage en mousse de polyuréthane à densité différenciée. Revêtement de l'assise non déhoussable, revêtement déhoussable pour le coussin de dos.

cm l.70 x p.72,5 x h.40 / 73

Nana / Design Paola Navone / pag. 91

Poltrona, struttura in massello di abete e multistrato di pioppo. Imbottitura in poliuretano espanso a densità differenziata. Piedi in massello di faggio tinto ebano. Rivestimento fisso.

cm l. 93 x p. 85 x h. 39 / 63

Armchair, solid pinewood structure and multi ply of birch wood. Upholstered in different densities of polyurethane foam. Feet in solid beech wood, ebony colour. Fixed cover.

cm l. 93 x p. 85 x h. 39 / 63

Sessel, Struktur aus Massivtannenholz und Multischicht Birke. Polsterung aus Polyurethanschaum mit differenzierter Dichte. Massive Buchenholzfüße, Ebenfarbe. Fester Bezug.

cm l. 93 x p. 85 x h. 39 / 63

Fauteuil, structure en sapin massif et multiplis de bouleau. Rembourrage en mousse de polyuréthane à densité différenciée. Pieds en hêtre massif, ton ébène. Revêtement non déhoussable.

cm l. 93 x p. 85 x h. 39 / 63

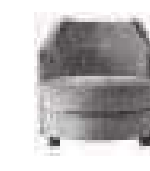
Sophie / Design Massimiliano Raggi / pag. 93

Poltrona, struttura in massello di abete e multistrato di pioppo. Imbottitura in poliuretano espanso a densità differenziata. Piedi in massello di faggio tinto ebano. Rivestimento sfoderabile (tessuto) / fisso (pelle).

cm. l. 72 x p.82 x h.40/75

Armchair. Solid pinewood frame, multi ply of poplar wood. Upholstered in different densities of polyurethane foam. Feet in solid beech wood, ebony colour. Removable cover (fabric) / fixed cover (leather).

cm. l. 72 x p.82 x h.40/75

Sessel. Struktur aus Massivtannenholz und Multischicht Pappelholz. Polsterung aus Polyurethanschaum mit differenzierter Dichte. Massive Buchenholzfüße, Ebenfarbe. Abnehmbarer Bezug (Stoff) / Fester Bezug (Leder).

cm. l. 72 x p.82 x h.40/75

Fauteuil. Structure en sapin massif et multiplis de peuplier. Rembourrage en mousse de polyuréthane à densités différentes. Pieds en hêtre massif, ton ébène. Revêtement déhoussable (tissu) / non déhoussable (cuir).

cm. l. 72 x p.82 x h.40/75

Big / Design Paola Navone / pag. 95

Poltrona, struttura in massello di abete e multistrato di pioppo. Imbottitura in poliuretano espanso a densità differenziata. Piedi in massello di faggio tinto ebano. Rivestimento sfoderabile (tessuto) / fisso (pelle).

cm.l.115xp.102 x h.38/79

Armchair, structure in solid pinewood and multi ply of poplar wood. Upholstered in different densities of polyurethane foam. Feet in solid beech wood, ebony colour. Removable cover (fabric) / fixed cover (leather).

cm.l.115xp.102 x h.38/79

Sessel, Struktur aus massivem Tannenholz und Pappelmultiplexplatte. Polsterung aus Polyurethanschaum mit differenzierter Dichte. Massive Buchenholz Füße, Ebenfarbe. Abnehmbarer Bezug (Stoff) / Fester Bezug (Leder).

cm.l.115xp.102 x h.38/79

Fauteuil, structure en sapin massif et multiplis de peuplier. Rembourrage en mousse de polyuréthane à densités différentes. Pieds en hêtre massif, ton ébène. Revêtement déhoussable (tissu) / non déhoussable (cuir).

cm.l.115xp.102 x h.38/79

Chloe / Design Castello Lagravinese / pag. 97

Poltrona, struttura in massello di abete e multistrato di pioppo. Imbottitura in poliuretano espanso a densità differenziata. Piedi in ABS. Rivestimento sfoderabile (tessuto) / fisso (pelle).

cm. l. 81 x p.81 x h.38/75

Armchair, solid pinewood structure and multi ply of poplar wood. Upholstered in different densities of polyurethane foam. ABS feet. Removable cover (fabric) / fixed cover (leather).

cm. l. 81 x p.81 x h.38/75

Sessel, Struktur aus Massivtannenholz und Multischicht Pappelholz. Polsterung aus Polyurethanschaum mit differenzierter Dichte. Füße: aus ABS. Abnehmbarer Bezug (Stoff) / Fester Bezug (Leder).

cm. l. 81 x p.81 x h.38/75

Fauteuil, structure en sapin massif et multiplis de peuplier. Rembourrage en mousse de polyuréthane à densités différentes. Pieds en ABS. Revêtement déhoussable (tissu) / non déhoussable (cuir).

cm. l. 81 x p.81 x h.38/75

Tabouret / Design Paola Navone / pag. 100

Pouff, struttura in massello e multistrato di abete. Imbottitura in poliuretano espanso. Piedi in ABS. Rivestimento fisso, con borchie in metallo cromato. Versione Ø 120 in tessuto, sfoderabile.

cm. Ø 45 h. 45
cm. Ø 120 h. 35

Ottoman, frame in solid and multi ply of pinewood. Upholstered in polyurethane foam. ABS feet. Fixed cover, with chrome metal studs. Model Ø 120: removable fabric cover.

cm. Ø 45 h. 45
cm. Ø 120 h. 35

Hocker, Struktur aus massivem Tannenholz und Tannenmultischichten. Polsterung aus Polyurethanschaum. Füße aus ABS. Fester Bezug, mit Chrom-Metallnieten. Modell Ø 120: Abnehmbarer Bezug (Stoff)

cm. Ø 45 h. 45
cm. Ø 120 h. 35

Pouf, structure en sapin massif et multiplis de sapin. Rembourrage en polyuréthane expansé. Pieds en ABS. Revêtement non déhoussable, avec clous en métal chromé. Modèle Ø 120 : en tissu, déhoussable.

cm. Ø 45 h. 45
cm. Ø 120 h. 35

Petite Lea / Design Paola Navone / pag. 101

Pouff, struttura in multistrato di pino e pioppo. Imbottitura in poliuretano espanso. Piedi in ABS. Rivestimento sfoderabile (tessuto) / fisso (pelle).

cm. l.55 x p.51 x h.35/54

Ottoman, structure in multi ply of pinewood and poplar. Upholstered in polyurethane foam. ABS feet. Removable cover (fabric) / fixed cover (leather).

cm. l.55 x p.51 x h.35/54

Hocker, Struktur aus Kiefer und Pappelholzschlierplatte (Capitonné Modell) / Kiefernultiplexplatte (Modell ohne Capitonné). Polsterung aus Polyurethanschaum. Füße aus ABS. Abnehmbarer Bezug (Stoff) / Fester Bezug (Leder).

cm. l.55 x p.51 x h.35/54

Pouf, structure en multiplis de pin et peuplier. Rembourrage en polyuréthane expansé. Pieds en ABS. Revêtement déhoussable (tissu) / non déhoussable (cuir).

cm. l.55 x p.51 x h.35/54

Hyatt / Design Castello Lagravinese / pag. 102, 103

Pouff, struttura in listellare di pioppo (versione capitonné) / multistrato di pino (versione non capitonné). Imbottitura in poliuretano espanso. Piedi in ABS. Rivestimento fisso (versione capitonné) / sfoderabile (versione non capitonné).

cm l. 120 x p.120 x h.37
cm. l.160 x p.55 x h.37

Ottoman, structure in poplar battenboard (capitonné model) / multi ply of pinewood (non capitonné model). Upholstered in polyurethane foam. ABS feet. Fixed cover (capitonné model), removable cover (non capitonné model).

cm l. 120 x p.120 x h.37
cm. l.160 x p.55 x h.37

Hocker, Struktur aus Pappelholzschlierplatte (Capitonné Modell) / Kiefernultiplexplatte (Modell ohne Capitonné). Polsterung aus Polyurethanschaum. Füße aus ABS. Fester Bezug (Modell mit Capitonné), abnehmbarer Bezug (Modell ohne Capitonné).

cm l. 120 x p.120 x h.37
cm. l.160 x p.55 x h.37

Pouf, structure en panneau latté de peuplier (modèle avec capitonné) / multiplis de pin (modèle sans capitonné). Rembourrage en polyuréthane expansé. Pieds en ABS. Revêtement non déhoussable (modèle en capitonné), déhoussable (modèle sans capitonné).

cm l. 120 x p.120 x h.37
cm. l.160 x p.55 x h.37

Duprè / Design Roberto Lazzeroni / pag. 33, 107, 109, 259, 267

Tavolino, struttura in metallo verniciato platino / bronzo. Piani: marmo / essenza.

cm. Ø 70 x h.53
cm. l.90 x p.40 x h.53

Small table, structure in metal, platino / bronze painted. Tops: marble / wood essence.

cm. Ø 70 x h.53
cm. l.90 x p.40 x h.53

Kleintisch, Struktur aus Metall, Platino / Bronze gefärbt. Platte: Marmor / Holzart.

cm. Ø 70 x h.53
cm. l.90 x p.40 x h.53

Petite table, structure en métal, verni couleur platino / bronze. Plateau : marbre / essence de bois.

cm. Ø 70 x h.53
cm. l.90 x p.40 x h.53

Mondrian / Design Massimiliano Raggi / pag. 111

Tavolino, struttura in MDF. Piani in MDF rivestiti in essenza. Finitura laccata. Le imperfezioni sono dovute alla lavorazione manuale, che rende ogni pezzo unico.

cm. Ø 65 x h.49

Small table, structure in MDF. Tops in MDF, covered in wood essence. Lacquered finish. Imperfections are due to hand-crafting, which makes every piece unique.

cm. Ø 65 x h.49

Kleintisch, Struktur aus MDF. Platten aus MDF, Holzart bedeckt. Ausführung: lackiert. Die Unregelmäßigkeiten sind auf die manuelle Bearbeitung zurückzuführen, die jedes Stück zum Unikat macht.

cm. Ø 65 x h.49

Petite table, structure en MDF. Plateaux en MDF, revêtus en essence de bois. Finition laquée. Les imperfections sont dues au travail manuel, qui rend chaque pièce unique.

cm. Ø 65 x h.49

Atlante / Design Massimiliano Raggi / pag. 97, 113

Tavolino, struttura in MDF rivestito in essenza. Piano in specchio bronzo. Finitura laccata. Le imperfezioni sono dovute alla lavorazione manuale, che rende ogni pezzo unico.

cm. l.55 x p.55 x h.56

Small table, MDF structure, covered in wood essence. Bronzed mirror top. Lacquered finish. Imperfections are due to hand-crafting, which makes every piece unique.

cm. l.55 x p.55 x h.56

Kleintisch, Struktur aus MDF, Holzart bedeckt. Platte aus Bronzespiegel. Ausführung: lackiert. Die Unregelmäßigkeiten sind auf die manuelle Bearbeitung zurückzuführen, die jedes Stück zum Unikat macht.

cm. l.55 x p.55 x h.56

Petite table, structure en MDF revêtue en essence de bois. Plateau en miroir bronzé. Finition laquée. Les imperfections sont dues au travail manuel, qui rend chaque pièce unique.

cm. l.55 x p.55 x h.56

Berlino / Design Massimiliano Raggi / pag. 52, 115

Tavolino, struttura in tamburato e particelle di legno, rivestito in essenza / laccato lucido. Gambe in massello di frassino tinto.

Ø 75 x h. 52

Small table, structure in honeycomb and particle-board, covered in wood essence / polished lacquered. Legs: painted solid ash wood.

Ø 75 x h. 52

Kleintisch, Struktur aus Verbundplatte und Spannholz, Holzart bedeckt / poliert lackiert. Basis: Kernholzesche, gefärbt.

Ø 75 x h. 52

Petite table, structure en panneau nid d'abeilles et particules de bois, revêtue en essence de bois / laquée polie. Pieds en frêne massif teinté.

Ø 75 x h. 52

Lugano / Design Massimiliano Raggi / pag. 117

Tavolino, struttura multistrato di pioppo e MDF, rivestito in essenza.

Ø 70 x h. 52

Small table, structure in multi ply of poplar and MDF, covered in wood essence.

Ø 70 x h. 52

Kleintisch, Struktur aus Pappelmultiplexplatte und MDF, Holzart bedeckt.

Ø 70 x h. 52

Petite table, structure en multiplis de peuplier et MDF, revêtue en essence de bois.

Ø 70 x h. 52

Bollywood - Bollywood bronze / Design Paola Navone / pag. 118, 119

Tavolino, struttura in MDF rivestita specchio argentato / bronzo.

cm. l.50 x p. 50 x h.33
cm. l.45 x p.45 x h.56

Small table, structure in MDF covered with silver / bronzed mirror.

cm. l.50 x p. 50 x h.33
cm. l.45 x p.45 x h.56

Kleintisch, Gestell aus MDF. Überzug aus versilbertem Spiegel / Bronzespiegel.

cm. l.50 x p. 50 x h.33
cm. l.45 x p.45 x h.56

Petite table, structure en MDF revêtue en miroir argenté / bronzé.

cm. l.50 x p. 50 x h.33
cm. l.45 x p.45 x h.56

Arne / Design Roberto Lazzeroni / pag. 6, 24, 67, 121, 125, 127, 129

Tavolo basso / tavolino. Piano in marmo / vetro retro verniciato / rivestito in essenza. Struttura in fusione di alluminio naturale, spazzolata, prodotta con metodo in sabbia naturale. Finitura color platino. Le imperfezioni sono dovute alla lavorazione manuale, che rende ogni pezzo unico.

Piano:
cm Ø 90 x h. 35
cm. Ø 120 x h. 35
cm. l. 140 x p. 70 x h. 35
cm. Ø 40 x h. 50

Low table / small table. Top: marble / glass painted on the back / covered in wood essence. Structure made of natural, brushed, aluminium casting, made using natural sand method. Finish: "platino" colour. Imperfections are due to hand-crafting, which makes every piece unique.

Top:
cm Ø 90 x h. 35
cm. Ø 120 x h. 35
cm. l. 140 x p. 70 x h. 35
cm. Ø 40 x h. 50

Beistelltisch / Kleintisch. Platte au: Marmor / hinter lackierter Glas / Holzart bedeckt. Hergestellt aus Aluminium-Guss, im Natursand-Verfahren gefertigt. Ausführung: "Platino" Farbe. Die Unregelmäßigkeiten sind auf die manuelle Bearbeitung zurückzuführen, die jedes Stück zum Unikat macht.

Platte:
cm Ø 90 x h. 35
cm. Ø 120 x h. 35
cm. l. 140 x p. 70 x h. 35
cm. Ø 40 x h. 50

Table basse / petite table. Plateau en marbre /en verre, verni au derrière / en essence de bois. Réalisée en fonte d'aluminium naturel, brossée, produite en utilisant du sable naturel. Finition: ton "platino". Les imperfections sont dues au travail manuel, qui rend chaque pièce unique.

Plateau:
cm Ø 90 x h. 35
cm. Ø 120 x h. 35
cm. l. 140 x p. 70 x h. 35
cm. Ø 40 x h. 50

Aldo / Design Casamilano studio / pag. 19, 34, 38, 43, 131, 133

Tavolo basso (con ruote), struttura in MDF (a folding), finitura laccata. Le imperfezioni sono dovute alla lavorazione manuale, che rende ogni pezzo unico.

cm. 92 x 80 x h. 32
cm. 53 x 73 x h. 32

Low table (on wheels), structure in MDF (folding), lacquered finish. Imperfections are due to hand-crafting, which makes every piece unique.

cm. 92 x 80 x h. 32
cm. 53 x 73 x h. 32

Beistelltisch (auf Rädern), Struktur aus MDF Folding. Ausführung: lackiert. Die Unregelmäßigkeiten sind auf die manuelle Bearbeitung zurückzuführen, die jedes Stück zum Unikat macht.

cm. 92 x 80 x h. 32
cm. 53 x 73 x h. 32

Table basse (sur roues), structure en MDF (folding), finition laquée. Les imperfections sont dues au travail manuel, qui rend chaque pièce unique.

cm. 92 x 80 x h. 32
cm. 53 x 73 x h. 32

Duprè / Design Roberto Lazzeroni / pag. 135

Tavolo basso, struttura in metallo verniciato platino / bronzo. Piani in marmo / essenza.

cm. l.130 x p.130 x h.36

Low table, structure in metal, platino / bronze painted. Tops in marble / wood essence.

cm. l.130 x p.130 x h.36

Beistelltisch, Struktur aus Metall, Platino / Bronze gefärbt. Platte aus Marmor / Holzart.

cm. l.130 x p.130 x h.36

Petite table, structure en métal, verni couleur platino / bronze. Plateau: en marbre/ essence de bois.

cm. l.130 x p.130 x h.36

	<p>Accademia / Design Massimiliano Raggi pag. 137, 139</p> <p>Tavolo basso, struttura in MDF, rivestito in essenza.</p> <p>cm. l.140 x p.140 x h.36 cm. l.140 x p. 80 x h. 36</p>	<p>Low table, structure in MDF, covered in wood essence.</p> <p>cm. l.140 x p.140 x h.36 cm. l.140 x p. 80 x h. 36</p>	<p>Beistelltisch, Gestell aus MDF, Holzart bedeckt.</p> <p>cm. l.140 x p.140 x h.36 cm. l.140 x p. 80 x h. 36</p>	<p>Table basse, structure en MDF revêtue en essence de bois</p> <p>cm. l.140 x p.140 x h.36 cm. l.140 x p. 80 x h. 36</p>
--	--	--	---	---

	<p>Mondrian / Design Massimiliano Raggi / pag. 140, 141</p> <p>Tavolo basso, struttura in multistrato di pioppo e MDF laccato. Piani in pannelli di particelle di legno e MDF rivestiti in essenza. Finitura laccata. Le imperfezioni sono dovute alla lavorazione manuale, che rende ogni pezzo unico.</p> <p>cm. l.130 x p.130 x h. 37 cm. l.160 x p.80 x h. 37</p>	<p>Low table, structure in poplar, multi ply and lacquered MDF. Tops in wooden particleboard panel and MDF, covered in wood essence. Lacquered finish. Imperfections are due to hand-crafting, which makes every piece unique.</p> <p>cm. l.130 x p.130 x h. 37 cm. l.160 x p.80 x h. 37</p>	<p>Beistelltisch, Struktur aus Pappelmultiplexplatte und lackiertem MDF. Platten aus Holzspanplatte und MDF, Holzart bedeckt. Ausführung: lackiert. Die Unregelmäßigkeiten sind auf die manuelle Bearbeitung zurückzuführen, die jedes Stück zum Unikat macht.</p> <p>cm. l.130 x p.130 x h. 37 cm. l.160 x p.80 x h. 37</p>	<p>Table basse, structure en multiplis de peuplier et MDF laqué. Plateaux en panneau de particules de bois et MDF revêtus en essence de bois. Finition laquée. Les imperfections sont dues au travail manuel, qui rend chaque pièce unique.</p> <p>cm. l.130 x p.130 x h. 37 cm. l.160 x p.80 x h. 37</p>
--	--	--	--	---

	<p>Rocco / Design Marco Boga pag. 13, 142, 143</p> <p>Tavolo basso (con ruote), struttura in MDF (a folding), finitura laccata. Le imperfezioni sono dovute alla lavorazione manuale, che rende ogni pezzo unico.</p> <p>cm. 120 x 85 x h. 26</p>	<p>Low table (on wheels), structure in MDF (folding), lacquered finish. Imperfections are due to hand-crafting, which makes every piece unique.</p> <p>cm. 120 x 85 x h. 26</p>	<p>Beistelltisch (auf Rädern), Struktur aus MDF (Folding). Ausführung: lackiert. Die Unregelmäßigkeiten sind auf die manuelle Bearbeitung zurückzuführen, die jedes Stück zum Unikat macht.</p> <p>cm. 120 x 85 x h. 26</p>	<p>Table basse (sur roues), structure en MDF (folding), finition laquée. Les imperfections sont dues au travail manuel, qui rend chaque pièce unique.</p> <p>cm. 120 x 85 x h. 26</p>
--	--	---	---	---

	<p>Bryant / Design Casamilano / pag. 145</p> <p>Tavolo basso (con ruote), struttura: pannello in particelle di legno rivestito in specchio bronzo.</p> <p>cm. l.120 x p.120 x h. 31 cm. l.160 x p.80 x h. 31</p>	<p>Low table (on wheels), structure in wooden particleboard panel, bronze mirror covered.</p> <p>cm. l.120 x p.120 x h. 31 cm. l.160 x p.80 x h. 31</p>	<p>Beistelltisch (auf Rädern), Struktur aus Holzspanplatte, Bronzespiegel bedeckt.</p> <p>cm. l.120 x p.120 x h. 31 cm. l.160 x p.80 x h. 31</p>	<p>Table basse (sur roues), structure en panneau de particules de bois revêtue en miroir bronzé.</p> <p>cm. l.120 x p.120 x h. 31 cm. l.160 x p.80 x h. 31</p>
--	---	---	--	--

	<p>Mondrian/17 / Design Massimiliano Raggi / pag. 149, 150</p> <p>Libreria, struttura in metallo, finitura laccata. Ripiani in pannelli di particelle di legno rivestiti in essenza. Le imperfezioni sono dovute alla lavorazione manuale, che rende ogni pezzo unico.</p> <p>cm. l. 125 x p.39 x h.220</p> <p>Fissare a parete / pavimento</p>	<p>Bookshelf, metal structure, lacquered finish. Shelves in particle-board panels, covered in wood essence. Imperfections are due to hand-crafting, which makes every piece unique.</p> <p>cm. l. 125 x p.39 x h.220</p> <p>Fix to the wall / floor</p>	<p>Bibliothek, Struktur aus Metall, Ausführung: lackiert. Regale in Spanholzplatten, Holzart bedeckt. Die Unregelmäßigkeiten sind auf die manuelle Bearbeitung zurückzuführen, die jedes Stück zum Unikat macht.</p> <p>cm. l. 125 x p.39 x h.220</p> <p>An der Wand/ auf dem Boden befestigen</p>	<p>Bibliothèque, structure en métal, finition laquée, étagères en panneau nid d'abeilles, revêtus en essence de bois. Les imperfections sont dues au travail manuel, qui rend chaque pièce unique.</p> <p>cm. l. 125 x p.39 x h.220</p> <p>Fixer au mur / au sol</p>
--	--	---	--	--

	<p>Klee / Design Massimiliano Raggi / pag. 27, 153</p> <p>Libreria componibile. Piani in pannelli di particelle di legno rivestiti in essenza. Supporti in MDF rivestiti in marmo e in essenza.</p> <p>Piani cm. l. 200 / 300 x p. 40 x h. 5 Supporti marmo cm l.15 x p. 30 x h. 35 Supporti legno cm l. 9 x p. 30 x h. 35</p> <p>Fissare a parete</p>	<p>Modular bookshelf. Shelves in particle-board panels, covered in wood essence. Supports in MDF, covered with marble and essence.</p> <p>Tops cm. l. 200 / 300 x p. 40 x h. 5 Marble supports cm l.15 x p. 30 x h. 35 Wooden supports cm l. 9 x p. 30 x h. 35</p> <p>Fix to wall</p>	<p>Modulares Bucherregal. Tablare aus Spanholzplatten, Holzart bedeckt. Seitenteile aus MDF, Marmor- und Holzart bedeckt.</p> <p>Tablare cm. l. 200 / 300 x p. 40 x h. 5 Marmor Seitenteile cm l.15 x p. 30 x h. 35 Holz Seitenteile cm l. 9 x p. 30 x h. 35</p> <p>An der Wand befestigen</p>	<p>Bibliothèque modulaire. Étagères en panneau nid d'abeilles, revêtus en essence de bois. Soutiens en MDF revêtus en marbre et bois.</p> <p>Étagères cm. l. 200 / 300 x p. 40 x h. 5 Soutiens en marbre cm l.15 x p. 30 x h. 35 Soutiens en bois cm l. 9 x p. 30 x h. 35</p> <p>Fixer au mur</p>
--	---	---	--	---

	<p>Orlando/17 / Design Roberto Lazzeroni / pag. 155, 157</p> <p>Contentore. Struttura, pannelli in particelle di legno rivestiti in essenza. Ante: MDF rivestite in essenza. Base in massello di faggio rivestito in essenza. Ripiani in vetro bronzo, spessore 8 mm. Schienale in specchio bronzo. Opzione maniglia: Madison / Wright. Le imperfezioni sono dovute alla lavorazione manuale, che rende ogni pezzo unico.</p> <p>cm. l. 112 x p.52 x h.160</p>	<p>Cabinet. Structure, panels in wood particles, covered in wood essence. Doors in MDF covered in type of wood. Base in solid beech wood, covered in wood essence. Shelves in bronzed glass, 8 mm thickness. Back in bronzed mirror. Handle option: Madison / Wright. Imperfections are due to manual workmanship that makes each piece unique.</p> <p>cm. l. 112 x p.52 x h.160</p>	<p>Möbel. Struktur, Platten in Spanholzplatten, Holzart bedeckt. Türen aus MDF Holzart bedeckt. Unterteil aus massivem Buchenholz, Holzart bedeckt. Regale aus bronziertem Glas, Dicke 8 mm. Rückenlehne aus Bronzespiegel. Griff-Option: Madison / Wright. Die Unregelmäßigkeiten sind auf die manuelle Bearbeitung zurückzuführen, die jedes Stück zum Unikat macht.</p> <p>cm. l. 112 x p.52 x h.160</p>
---	---	--	---

	<p>Garbo / Design Casamilano studio / pag. 159, 161</p> <p>Credenza, struttura in MDF rivestito in essenza. Maniglie e piedi in metallo, finitura laccata. Ripiani in vetro bronzo temperato spessore 8 mm. Le imperfezioni sono dovute alla lavorazione manuale, che rende ogni pezzo unico.</p> <p>cm l. 240 x p.48 x h.85</p>	<p>Sideboard, MDF structure, covered in wood essence. Metal handles and feet, lacquered finish. 8 mm thickness tempered glass shelves, bronze colour. Imperfections are due to hand-crafting, which makes every piece unique.</p> <p>cm l. 240 x p.48 x h.85</p>	<p>Möbel, Struktur aus MDF, Holzart bedeckt. Handgriffe und Füße aus Metall, Ausführung: lackiert. Regale aus gehärtetem Glas, Dicke 8 mm, bronzefarbig. Die Unregelmäßigkeiten sind auf die manuelle Bearbeitung zurückzuführen, die jedes Stück zum Unikat macht.</p> <p>cm l. 240 x p.48 x h.85</p>
---	---	--	--

	<p>Arne / Design Roberto Lazzeroni / pag. 163, 165, 167</p> <p>Contentore, struttura in MDF rivestito rovere fiammato spazzolato tinto. Piano in marmo / essenza. Ripiano in vetro bronzo temperato spessore 8 mm. Cassetto interno in MDF rivestito in essenza, con guida ammortizzata "bluemotion", cerniere in acciaio brunito (Air) Maniglia in MDF laccata color platino.</p> <p>cm. l. 240 x p. 57 x h. 76 (con piedi H. 25) cm. l. 240 x p. 57 x h. 53 (con piedi H. 3)</p>	<p>Cabinet. Structure in MDF covered in type of wood (veined oak, brushed and painted). Top in marble / wood. 8 mm thickness tempered glass shelf, bronze colour. Inside drawer in MDF covered in type of wood, having amortized "bluemotion" slide runner. Burnished steel hinges (Air) MDF lacquered handle, "platino" colour.</p> <p>cm. l. 240 x p. 57 x h. 76 (with feet H. 25) cm. l. 240 x p. 57 x h. 53 (with feet H. 3)</p>	<p>Möbel, Struktur aus MDF, Holzart bedeckt (gebürstete geflammte Eiche). Platte aus Marmor / Holzart bezogen. Regale aus gehärtetem Glas, Dicke 8 mm., bronzefarbig. Innenschublade aus MDF, Holzart bedeckt, mit Bluemotion Mechanismus. Scharniere aus brüniertem Stahl (Air). Griff aus lackiertem MDF, "Platino" Farbe lackiert.</p> <p>cm. l. 240 x p. 57 x h. 76 (mit Füße H. 25) cm. l. 240 x p. 57 x h. 53 (mit Füße H. 3)</p>
---	---	--	---

	<p>Mondrian / Design Massimiliano Raggi / pag. 169</p> <p>Elemento a giorno / TV, struttura in multistrato di pioppo e MDF laccato. Piani in pannelli di particelle di legno e MDF rivestito in essenza. Le imperfezioni sono dovute alla lavorazione manuale, che rende ogni pezzo unico.</p> <p>cm. l. 205 x p.42 x h.55</p>	<p>Shelf-unit / TV, structure in poplar multi ply and lacquered MDF. Tops in wood particleboard and MDF, covered in type of wood. Imperfections are due to hand-crafting, which makes every piece unique.</p> <p>cm. l. 205 x p.42 x h.55</p>	<p>Fachmöbel / TV, Struktur aus Pappelmultiplexplatte und lackiertem MDF. Platte aus Holzspanplatte und MDF, Holzart beschichtet. Die Unregelmäßigkeiten sind auf die manuelle Bearbeitung zurückzuführen, die jedes Stück zum Unikat macht.</p> <p>cm. l. 205 x p.42 x h.55</p>
---	---	---	--



**Kelly** / Design Design Massimiliano Raggi / pag. 173, 175, 209

Sedia, struttura in massello di frassino tinto ebano.
Schienale in multistrato curvato, impiallacciato in frassino.
Seduta imbottita in poliuretano espanso.
Rivestimento sfoderabile (tessuto) / fisso (pelle).

Chair, structure in solid ash-wood, ebony colour.
Back in bent multi ply, ash-wood veneered.
Seat upholstered in polyurethane foam.
Removable cover (fabric) / fixed cover (leather).

Stuhl, Struktur aus Eschenholz, Ebenfarbe.
Rücklehne aus gebogener Multiplexplatte, Esche furniert.
Sitzpolsterung aus Polyurethanschaum.
Abnehmbarer Bezug (Stoff) / Fester Bezug (Leder).

Chaise, structure en frêne massif, ton ébène.
Dos en multiplis courbé, frêne plaqué.
Assise rembourrée en polyuréthane expansé.
Revêtement: déhoussable (tissu) / non déhoussable (cuir).

cm. l. 55 x p. 50 x h. 47 / 84

cm. l. 55 x p. 50 x h. 47 / 84

cm. l. 55 x p. 50 x h. 47 / 84

cm. l. 55 x p. 50 x h. 47 / 84

**Brigitte** / Design Massimiliano Raggi / pag. 177, 179

Sedia, struttura in metallo tubolare Ø 18 mm, verniciato.
Schienale in multistrato curvato.
Imbottitura in poliuretano espanso.
Braccioli: in poliuretano semi rigido, rivestito.
Rivestimento sedile: sfoderabile (tessuto) / fisso (pelle).
Rivestimento schienale e braccioli: fisso.

Chair, structure in metal tubular Ø 18 mm., painted.
Back in bent multi ply.
Upholstery in polyurethane foam.
Armrests: in semi-rigid polyurethane, covered.
Seat: removable cover (fabric) / fixed cover (leather).
Back and armrests: fixed cover.

Stuhl, Struktur aus Metallrohrstück, Ø 18 mm., lackiert.
Rücklehne aus gebogener Multiplexplatte.
Polsterung aus Polyurethanschaum.
Armlehnen: aus semi-Steifpolyurethan, bezogen.
Sitz: Abnehmbarer Bezug (Stoff) / Fester Bezug (Leder).
Rücklehne und Armlehnen: Fester Bezug.

Chaise, structure en boyau en métal Ø 18 mm., verni.
Dos en multiplis courbé.
Rembourrage en polyuréthane expansé.
Accoudoirs : en polyuréthane semi-rigide, revêtus.
Revêtement de l'assise: déhoussable (tissu) / non déhoussable (cuir).
Revêtement du dos et des accoudoirs: non déhoussable.

cm. l. 54 x p.55 x h. 47 / 80

cm. l. 54 x p.55 x h. 47 / 80

cm. l. 54 x p.55 x h. 47 / 80

cm. l. 54 x p.55 x h. 47 / 80

**Elsa** / Design Castello Lagravinese / pag. 181, 183, 211, 217

Sedia, struttura in massello di faggio e compensato curvato.
Imbottitura in poliuretano espanso.
Gambe in massello di rovere tinto.
Rivestimento fisso.

Chair, structure in solid beech wood and curved plywood.
Upholstered in polyurethane foam.
Solid oak painted wooden legs.
Fixed cover.

Stuhl, Struktur aus Buchenmassivholz und gebogenem Sperrholz.
Polsterung aus Polyurethanschaum.
Beine aus Massivholz / bezogen. Fester Bezug.

Chaise, structure en hêtre massif et contreplaqué cintré.
Rembourrage en mousse de polyuréthane.
Pieds en chêne massif teinté.
Revêtement non déhoussable.

cm. l. 56 x p. 55 x h. 46 / 77

cm. l. 56 x p. 55 x h. 46 / 77

cm. l. 56 x p. 55 x h. 46 / 77

cm. l. 56 x p. 55 x h. 46 / 77

**Royale** / Design Castello Lagravinese / pag. 185, 187, 213, 223

Sedia, struttura in massello di faggio e compensato curvato. Imbottitura in poliuretano espanso. Gambe in massello di rovere tinto / rivestite. Rivestimento fisso.

Chair, structure in solid beech wood and curved plywood. Upholstered in polyurethane foam. Solid oak painted wooden legs / covered. Fixed cover.

Stuhl, Struktur aus Buchenmassivholz und gebogenem Sperrholz. Polsterung aus Polyurethanschaum. Beine aus Massivholz / bezogen. Fester Bezug.

Chaise, structure en hêtre massif et contreplaqué cintré. Rembourrage en mousse de polyuréthane. Pieds en chêne massif / revêtus. Revêtement non déhoussable.

cm. l.56 x p.58 x h.46/82

cm. l.56 x p.58 x h.46/82

cm. l.56 x p.58 x h.46/82

cm. l.56 x p.58 x h.46/82

**Diana** / Design Castello Lagravinese / pag. 189

Sedia, struttura in massello di faggio e compensato curvato. Imbottitura in poliuretano espanso. Gambe in massello di rovere tinto / rivestite. Rivestimento fisso.

Chair, structure in solid beech wood and curved plywood. Upholstered in polyurethane foam. Solid oak painted wooden legs / covered. Fixed cover.

Stuhl, Struktur aus Buchenmassivholz und gebogenem Sperrholz. Polsterung aus Polyurethanschaum. Beine aus gefärbter Massivholz / bezogen. Fester Bezug.

Chaise, structure en hêtre massif et contreplaqué cintré. Rembourrage en mousse de polyuréthane. Pieds en chêne massif teinté / revêtus. Revêtement non déhoussable.

cm. l.57 x p.63 x h. 46/103

cm. l.57 x p.63 x h. 46/103

cm. l.57 x p.63 x h. 46/103

cm. l.57 x p.63 x h. 46/103

**Arne** / Design Roberto Lazzeroni / pag. 191, 193, 202, 207

Sedia, struttura in massello di frassino tinto. Inserto seduta e schienale in multistrato curvato di pino. Imbottitura in poliuretano espanso a densità differenziata. Rivestimento seduta fisso, cuscino schienale sfoderabile

Chair, painted solid ash-wooden structure.
Seat and back insert in bent multi ply of pine wood.
Upholstered in different densities of polyurethane foam.
Fixed cover for the seat, removable cover for the back cushion.

Stuhl, Struktur aus Eschenholz. Sitzeinsatz und Rücklehne aus gebogenem Kiefer Multischichter. Polsterung aus Polyurethanschaum mit differenzierter Dichte. Fester Sitzbezug, abnehmbares Rückenissen.

Chaise, structure en frêne massif. Insert pour l'assise et le dos en contreplaqué courbé de pin. Rembourrage en mousse de polyuréthane à densité différenciée. Revêtement de l'assise non déhoussable, revêtement déhoussable pour le coussin de dos.

cm. l. 60 x p. 61 x h. 46 / 80

cm. l. 60 x p. 61 x h. 46 / 80

cm. l. 60 x p. 61 x h. 46 / 80

cm. l. 60 x p. 61 x h. 46 / 80

**Quadra** / Design Marco Boga / pag. 195

Sedia, struttura in poliuretano flessibile. Autoestinguente. Schienale flessibile. Inserto profilato in acciaio. Gambe in massello di rovere tinto / rivestite. Rivestimento sfoderabile (tessuto) / fisso (pelle).

Chair, flexible polyurethane structure. Self-extinguishing. Flexible back. Steel profile insert. Solid oak painted wooden legs / covered. Removable cover (fabric) / fixed (leather).

Stuhl, Struktur aus flexiblem Polyurethan. Selbstverlöschend. Flexible Rückenlehne. Profileinsatz aus Stahl. Beine aus gefärbter Massivholz / bezogen. Abnehmbarer Bezug (Stoff) / Fester Bezug (Leder).

Chaise, structure en polyuréthane flexible. Auto extinguable. Dossier flexible. Insert profilé en acier. Pieds en chêne massif teinté / revêtus. Revêtement déhoussable (tissu) / non déhoussable (cuir).

cm. l.56 x p.58 x h.46/79

cm. l.56 x p.58 x h.46/79

cm. l.56 x p.58 x h.46/79

cm. l.56 x p.58 x h.46/79

**Costanza** / Design Marco Boga / pag. 197

Sedia, struttura in poliuretano flessibile. Autoestinguente. Schienale flessibile. Inserto profilato in acciaio. Cuscino in poliuretano espanso. Gambe in massello di rovere tinto. Rivestimento sfoderabile (tessuto) / fisso (pelle).

Chair, flexible polyurethane structure. Self-extinguishing. Flexible back. Steel profile insert. Polyurethane foam cushion, solid oak painted wooden legs. Removable cover (fabric) / fixed cover (leather).

Stuhl, Struktur aus flexiblem Polyurethan. Selbstverlöschend. Flexible Rückenlehne. Profileinsatz aus Stahl. Kissen: Polsterung aus Polyurethanschaum. Beine aus gefärbter Massivholz / bezogen. Abnehmbarer Bezug (Stoff) / Fester Bezug (Leder).

Chaise, structure en polyuréthane flexible. Autoextinguible. Dossier flexible. Insert profilé en acier. Coussin en mousse de polyuréthane. Pieds en chêne massif teinté. Revêtement déhoussable (tissu) / non déhoussable (cuir).

cm. l.50 x p.54 x h.47/82

cm. l.50 x p.54 x h.47/82

cm. l.50 x p.54 x h.47/82

cm. l.50 x p.54 x h.47/82

**Magenta** / Design Castello Lagravinese / pag. 199

Sedia, struttura in massello e multistrato di pioppo. Imbottitura in poliuretano espanso. Gambe in massello di rovere tinto. Rivestimento sfoderabile (tessuto) / fisso (pelle).

Chair, structure in solid wood and multi ply of poplar. Upholstered in polyurethane foam. Solid oak painted wooden legs. Removable cover (fabric) / fixed (leather).

Stuhl, Struktur aus Massivholz und Multischichter Pappelholz. Polsterung aus Polyurethanschaum. Beine aus gefärbter Massivholz. Abnehmbarer Bezug (Stoff) / Fester Bezug (Leder).

Chaise, structure en bois massif et multiplis de peuplier. Rembourrage en mousse de polyuréthane. Pieds en chêne massif teinté. Revêtement déhoussable (tissu) / non déhoussable (cuir).

cm. l.56 x p.61 x h. 46/77

cm. l.56 x p.61 x h. 46/77

cm. l.56 x p.61 x h. 46/77

cm. l.56 x p.61 x h. 46/77

**Arne** / Design Roberto Lazzeroni / pag. 203, 205, 207, 209, 211

Tavolo, piano in marmo/ vetro retroverniciato. Sottopiano in MDF laccato. Gambe rivestite in pelle/frassino fiammato tinto, in compensato curvato e multistrato di pioppo. Puntali e piastre in acciaio verniciato color platino.

Table, marble top / glass top painted on the back. Under-top in lacquered MDF. Legs covered with leather / flamed ash wood painted, in curved plywood and multi ply of poplar. Painted steel ferrules, "platino" colour.

Tisch, Platte aus Marmor / hinter lackierter Glas. Unterplatte aus lackiertem MDF. Beine aus gebogenem Sperrholz und Pappelholzmultiplex, bezogen in Leder / Fiammungesche gefärbt. Fußende aus "Platino" Farbe, lackiertem Stahl.

Table, plateau en marbre / verre verni au derrière. Sous plateau en MDF laqué. Pieds revêtus en cuir / en frêne flammé verni, en contreplaqué courbé et multiplis de peuplier. Embouts en acier verni couleur "platino".

cm. Ø 160 / 180 x h. 75
cm. l. 240/280 x p. 120 x h. 75 (ovale)
cm. l. 300 x p. 120 x h. 75cm. Ø 160 / 180 x h. 75
cm. l. 240/280 x p. 120 x h. 75 (oval)
cm. l. 300 x p. 120 x h. 75cm. Ø 160 / 180 x h. 75
cm. l. 240/280 x p. 120 x h. 75 (Oval)
cm. l. 300 x p. 120 x h. 75cm. Ø 160 / 180 x h. 75
cm. l. 240/280 x p. 120 x h. 75 (ovale)
cm. l. 300 x p. 120 x h. 75**Kandinsky** / Design Massimiliano Raggi / pag. 213, 215, 217

Tavolo, piano in marmo / rivestito in essenza. Sottopiano in MDF laccato. Base in MDF laccato. Le imperfezioni sono dovute alla lavorazione manuale, che rende ogni pezzo unico.

Table, top: marble / covered in wood essence. Under-top in lacquered MDF. Base in MDF lacquered finish. Imperfections are due to hand-crafting, which makes every piece unique.

Tisch, Platte aus Marmor / Holzart bedeckt. Unterplatte aus lackiertem MDF. Basis aus lackiertem MDF. Die Unregelmäßigkeiten sind auf die manuelle Bearbeitung zurückzuführen, die jedes Stück zum Unikat macht.

Table, plateau en marbre / revêtu en essence de bois. Sous-plateau : en MDF laqué. Base en MDF laquée. Les imperfections sont dues au travail manuel, qui rend chaque pièce unique.

cm. l. 240 / 280 x p. 120 x h. 75 (ovale)
cm. l. 280 / 300 / 400 x p. 120 x h. 75
cm. Ø 160 x h. 75
cm. l. 160 x p. 160 x h. 75cm. l. 240 / 280 x p. 120 x h. 75 (oval)
cm. l. 280 / 300 / 400 x p. 120 x h. 75
cm. Ø 160 x h. 75
cm. l. 160 x p. 160 x h. 75cm. l. 240 / 280 x p. 120 x h. 75 (Oval)
cm. l. 280 / 300 / 400 x p. 120 x h. 75
cm. Ø 160 x h. 75
cm. l. 160 x p. 160 x h. 75cm. l. 240 / 280 x p. 120 x h. 75 (ovale)
cm. l. 280 / 300 / 400 x p. 120 x h. 75
cm. Ø 160 x h. 75
cm. l. 160 x p. 160 x h. 75**Bridge** / Design Marco Boga / pag. 219, 221

Tavolo, piano in marmo / rivestito in essenza / laccato / vetro retro verniciato. Sottopiano in MDF laccato. Base multistrato di betulla, finitura laccata. Le imperfezioni sono dovute alla lavorazione manuale, che rende ogni pezzo unico.

Table, top in marble / covered in wood essence / lacquered / glass top painted on the back. Base in multi ply of birch wood, lacquered finish. Imperfections are due to hand-crafting, which makes every piece unique.

Tisch, Platte aus Marmor / Holzart bedeckt / lackiert/ hinter lackierter Glasplatte. Unterteil aus Multiplexplatte-Birke. Ausführung: lackiert. Die Unregelmäßigkeiten sind auf die manuelle Bearbeitung zurückzuführen, die jedes Stück einzigartig macht.

Table, plateau en marbre / revêtu en essence de bois / laqué / en verre, verni au derrière. Sous-plateau en MDF laqué. Base en multiplis de bouleau, finition laquée. Les imperfections sont dues au travail manuel, qui rend chaque pièce unique.

cm. l. 240 / 280 x p. 120 x h. 73 (ovale)

cm. l. 240 / 280 x p. 120 x h. 73 (oval)

cm. l. 240 / 280 x p. 120 x h. 73 (Oval)

cm. l. 240 / 280 x p. 120 x h. 73 (ovale)

	<p>Empire / Design Marco Boga / pag. 223, 225</p> <p>Tavolo, piano in marmo / rivestito in essenza. Sottopiano in MDF laccato. Base multistrato di pioppo e MDF laccata. Le imperfezioni sono dovute alla lavorazione manuale, che rende ogni pezzo unico.</p> <p>cm l. 240 / 280 x p. 120 x h. 75 (ovale) cm l. 280 / 300 / 400 x p. 120 x h. 75</p>	<p>Table, top in marble / covered in wood essence. Under-top: in lacquered MDF. Base in multi ply of poplar wood and MDF, lacquered finish. Imperfections are due to hand-crafting, which makes every piece unique.</p> <p>cm l. 240 / 280 x p. 120 x h. 75 (oval) cm l. 280 / 300 / 400 x p. 120 x h. 75</p>	<p>Tisch, Platte aus Marmor / Holzart bedeckt. Unterplatte: aus lackiertem MDF. Unterteil aus Multiplexplatte-Pappel und MDF Ausführung: lackiert. Die Unregelmäßigkeiten sind auf die manuelle Bearbeitung zurückzuführen, die jedes Stück einzigartig macht.</p> <p>cm l. 240 / 280 x p. 120 x h. 75 (Oval) cm l. 280 / 300 / 400 x p. 120 x h. 75</p>	<p>Table, plateau en marbre / revêtu en essence de bois. Sous-plateau en MDF laqué. Base en multiplis de peuplier et MDF, finition laquée. Les imperfections sont dues au travail manuel, qui rend chaque pièce unique.</p> <p>cm l. 240 / 280 x p. 120 x h. 75 (ovale) cm l. 280 / 300 / 400 x p. 120 x h. 75</p>
---	--	---	--	--

	<p>Atlante / Design Massimiliano Raggi / pag. 229</p> <p>Console, struttura in MDF rivestita in essenza, finitura laccata. Piano in specchio bronzo. Le imperfezioni sono dovute alla lavorazione manuale, che rende ogni pezzo unico.</p> <p>cm. l.140 x p.42 x h.85</p>	<p>Console, MDF structure covered in wood essence, lacquered finish. Bronzed mirror top. Imperfections are due to hand-crafting, which makes every piece unique.</p> <p>cm. l.140 x p.42 x h.85</p>	<p>Konsole, Struktur aus MDF, Holzart bedeckt. Ausführung: lackiert. Platte aus Bronzespiegel. Die Unregelmäßigkeiten sind auf die manuelle Bearbeitung zurückzuführen, die jedes Stück zum Unikat macht.</p> <p>cm. l.140 x p.42 x h.85</p>	<p>Console, structure en MDF, revêtue en essence de bois, finition laquée. Plateau en miroir bronzé. Les imperfections sont dues au travail manuel, qui rend chaque pièce unique.</p> <p>cm. l.140 x p.42 x h.85</p>
--	--	---	--	--

	<p>Ernest / Design E. Garbin M. Dell'Orto / pag. 231</p> <p>Scrivania, piano in MDF con cassetto rivestito in essenza, base in acciaio satinato bronzato.</p> <p>cm. l.145 x p.70 x h.77</p>	<p>Writing-desk, MDF top with drawer, covered in wood essence, base in steel satin finish bronzed.</p> <p>cm. l.145 x p.70 x h.77</p>	<p>Schreibtisch, MDF Platte mit Schublade, Holzart bedeckt, Unterteil aus bronziertem satiniertem Stahl.</p> <p>cm. l.145 x p.70 x h.77</p>	<p>Bureau, plateau en MDF avec un tiroir, revêtu en essence de bois, base en acier satiné bronzé.</p> <p>cm. l.145 x p.70 x h.77</p>
--	---	---	---	--

	<p>Shard / Design Massimiliano Raggi / pag. 10, 97, 113, 209, 234, 267</p> <p>Applique in metallo verniciato. N. 6 lampadine attacco GU10 a Led 5 Watt max. (non incluse).</p> <p>cm l. 20 x p. 20 x h. 60</p>	<p>Wall lamp in painted metal. N. 6 GU10 LED 5 Watt max bulbs (not included).</p> <p>cm l. 20 x p. 20 x h. 60</p>	<p>Wandleuchter aus lackiertem Metall. N. 6 GU10 LED-Birne 5 Watt max (nicht enthalten).</p> <p>cm l. 20 x p. 20 x h. 60</p>	<p>Applique en métal verni. N. 6 GU10 ampoules à LED 5 Watt max (non inclus) .</p> <p>cm l. 20 x p. 20 x h. 60</p>
---	---	---	--	--

	<p>Shard / Design Massimiliano Raggi / pag. 237</p> <p>Lampadario in metallo verniciato. N. 12 lampadine attacco GU10 a Led max. 5 Watt (non incluse). Peso kg. 15.</p> <p>cm Ø 50 x h. 85</p>	<p>Suspension in painted metal. N. 12 GU10 LED 5 Watt max bulbs (not included). Weight kg. 15.</p> <p>cm Ø 50 x h. 85</p>	<p>Hängelampe aus lackiertem Metall. N. 12 GU10 LED-Birne 5 Watt max. (nicht enthalten). Gewicht Kg. 15.</p> <p>cm Ø 50 x h. 85</p>	<p>Lustre en métal verni. N. 12 GU10 ampoules à LED 5 Watt max (non inclus). Poids kg. 15.</p> <p>cm Ø 50 x h. 85</p>
--	---	---	---	---

	<p>Andromeda / Design Massimiliano Raggi / pag. 7, 19, 207, 211, 213, 239</p> <p>Lampadario in alluminio verniciato color platino, sostenuto da 4 cavi in acciaio, regolabili in altezza. N. 4 lampadine E27 alogene da 57 Watt (incluse) (idoneo all'uso anche di lampadine a Led o max 60 Watt). Peso kg. 10</p> <p>cm. Ø 80 x h. 36 (altezza max comprensiva di cavi 230 cm).</p>	<p>Suspension lamp in painted aluminium, "platino" colour. Supported by 4 steel cables, adjustable height. N. 4 halogen bulbs E27, 57 Watt (included). (Suitable also for Led bulbs or max 60 Watt bulbs). Weight kg. 10.</p> <p>cm. Ø 80 x h. 36 (max H. 230 cm, cables included).</p>	<p>Hängelampe aus lackiertem Aluminium, "Platino" Farbe. Unterstützt von 4 höhenverstellbaren Stahlseilen. N. 4 Halogen E27-Birnen à 57 Watt enthalten. (Geeignet auch mit LED-Birnen oder max. 60 Watt) Gewicht 10 kg.</p> <p>cm. Ø 80 x h. 36 (Max. Höhe inkl. 230 cm Seilen)</p>	<p>Lustre en aluminium verni, ton "platino". Soutenu par 4 câbles en acier, hauteur réglable. N. 4 ampoules halogènes E27, 57 Watt (compris). (Ça convient également pour une utilisation avec des ampoules LED ou max 60 Watt). Poids kg. 10</p> <p>cm. Ø 80 x h. 36 (H. max. câble compris 230 cm)</p>
--	---	---	---	--

	<p>Sign / Design Massimiliano Raggi / pag. 35, 39, 85, 87, 180, 202, 217, 241</p> <p>Applique – lampada da parete in metallo verniciato color platino. Non necessita di impianto elettrico a muro, in quanto fornita di cavo esterno, spina e interruttore a pedale. Led a luce calda integrato 15+20 Watt (potenza totale 35 Watt) incluso. Da appendere a parete in verticale con staffa in dotazione. Cavo in tessuto nero, lunghezza totale 270 cm (120 cm all'interruttore + 150 cm alla spina).</p> <p>cm. h. 150 x l. 12 x p. 6</p>	<p>Wall lamp in painted metal, "platino" colour. It does not need a wall electrical system, as it is equipped with an external cable, a plug and a foot switch. LED with integrated warm light 15 + 20 Watt (total power 35 Watt) included. Please hang vertically on the wall with the supplied bracket. Black fabric cable, length cm 120 to the switch + cm 150 to the plug = total length cm 270.</p> <p>cm. h. 150 x l. 12 x p. 6</p>	<p>Wandleuchter aus lackiertem Metall, "Platino" Farbe. Stromversorgungssystem nicht nötig, da es mit externem Kabel, elektrischem Stecker und Netzteil mit Fußpedal ausgestattet ist. LED mit integriertem Warmlicht 15 + 20 Watt (Gesamtleistung 35 Watt) enthalten. An der Wand mit mitgelieferter Halterung vertikal zu hängen. Gesamte Kabellänge in schwarzem Stoff L. 270cm (120cm zum Fußpedal Netzteil + 150cm zum Stecker).</p> <p>cm. h. 150 x l. 12 x p. 6</p>	<p>Applique en métal verni, ton "platino". La lampe n'a pas besoin d'un système électrique mural, car elle est équipée par un câble extérieur, une fiche électrique et un interrupteur au pied. LED avec lumière chaude intégrée 15 + 20 Watt (puissance totale 35 Watt) compris. A accrocher verticalement sur le mur avec le support fourni. Câble en tissu noir, longueur cm 120 jusqu'à l'interrupteur + cm 150 jusqu'à la fiche électrique = longueur totale cm 270 cm.</p> <p>cm. h. 150 x l. 12 x p. 6</p>
--	---	--	--	---

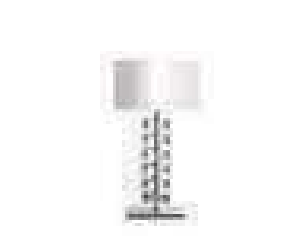
	<p>Vendome / Design Massimiliano Raggi / pag. 242, 261</p> <p>Lampada in plexiglass trasparente e acciaio cromo lucido. Paralume rivestito in tessuto accoppiato a PVC. Lampadina cablaggio CE max 100 Watt E27. Cavo elettrico in PVC.</p> <p>cm l. 23 x p. 23 x h. 66</p>	<p>Lamp in transparent plexiglas and polished, chromed steel. Lampshade covered with fabric and coupled to PVC. CE wiring bulb max 100 Watt E27. PVC electric wire.</p> <p>cm l. 23 x p. 23 x h. 66</p>	<p>Lampe aus transparentem Plexiglas und Glanz-Chromstahl. Lampenschirm aus PVC, Stoff bezogen. CE-Verkabelung Birne max 100 Watt E27. Elektrischer Draht aus PVC.</p> <p>cm l. 23 x p. 23 x h. 66</p>	<p>Lampe en plexiglas transparent et acier chromé brillant, abat-jour revêtu en tissu couplé par PVC. Ampoule, câblage CE, max 100 Watt E27. Fil électrique en PVC.</p> <p>cm l. 23 x p. 23 x h. 66</p>
---	--	---	--	---

	<p>Viola / Design Marco Boga / pag. 118, 231, 242</p> <p>Lampada in metallo verniciato, paralume rivestito in tessuto accoppiato a PVC. Lampadina cablaggio CE max 100 Watt E27. Cavo elettrico in PVC.</p> <p>cm. l.17 x p.17 x h.63</p>	<p>Lamp, painted metal structure. Lampshade covered with fabric and coupled to PVC. CE wiring blub max. 100 Watt E27. PVC electric wire.</p> <p>cm. l.17 x p.17 x h.63</p>	<p>Lampe, Struktur aus lackiertem Metall. Lampenschirm aus PVC, Stoff bezogen. CE-Verkabelung Birne max 100 Watt E27. Elektrischer Draht aus PVC.</p> <p>cm. l.17 x p.17 x h.63</p>	<p>Lampe, structure en métal verni, abat-jour revêtu en tissu couplé par PVC. Ampoule, câblage CE, max 100 Watt E27. Fil électrique en PVC.</p> <p>cm. l.17 x p.17 x h.63</p>
---	--	--	---	---

	<p>Elettra bronze / Design Casamilano / pag. 119, 139, 166, 243</p> <p>Lampada, base in MDF rivestita in specchio bronzo e metallo verniciato bronzo. Paralume rivestito in tessuto accoppiato a PVC. Lampadina cablaggio CE max 100 Watt E27. Cavo elettrico in PVC.</p> <p>cm l. 36 x p. 32 x h. 73</p>	<p>Lamp, MDF base covered in bronzed mirror and bronzed painted metal. Lampshade covered with fabric and coupled to PVC. CE wiring blub max. 100 Watt E27. PVC electric wire.</p> <p>cm l. 36 x p. 32 x h. 73</p>	<p>Lampe, MDF Unterteilbedeckt auf Bronzespiegel und Bronzefarbe lackiertem Metall. Lampenschirm aus PVC, Stoff bezogen. CE-Verkabelung Birne max 100 Watt E27. Elektrischer Draht aus PVC .</p> <p>cm l. 36 x p. 32 x h. 73</p>	<p>Lampe, structure en MDF revêtu en miroir bronzé et métal teinté bronze. Abat-jour revêtu en tissu couplé par PVC. Ampoule, câblage CE, max 100 Watt E27. Fil électrique en PVC.</p> <p>cm l. 36 x p. 32 x h. 73</p>
--	--	---	--	--

	<p>Viola XL / Design Marco Boga / pag. 47, 244, 259, 263</p> <p>Lampada struttura in metallo verniciato, paralume rivestito in tessuto accoppiato a PVC. Lampadina cablaggio CE max 100 Watt E27. Cavo elettrico in PVC.</p> <p>cm l. 28 x p. 28 x h. 130</p>	<p>Lamp, painted metal structure. Lampshade covered with fabric, coupled to PVC. CE wiring blub max. 100 Watt E27. PVC electric wire.</p> <p>cm l. 28 x p. 28 x h. 130</p>	<p>Lampe, Struktur aus lackiertem Metall. Lampenschirm aus PVC, Stoff bezogen. CE-Verkabelung Birne max 100 Watt E27. Elektrischer Draht aus PVC.</p> <p>cm l. 28 x p. 28 x h. 130</p>	<p>Lampe, structure en métal verni, abat-jour revêtu en tissu couplé par PVC. Ampoule, câblage CE, max 100 Watt E27. Fil électrique en PVC.</p> <p>cm l. 28 x p. 28 x h. 130</p>
---	--	--	--	--

	<p>Jackie / Design Massimiliano Raggi / pag. 41, 56, 79, 116, 245</p> <p>Lampada in metallo verniciato, paralume rivestito in tessuto accoppiato a PVC. Lampadina cablaggio CE max 100 Watt E27. Cavo elettrico in PVC.</p> <p>cm. l.30 x p.20 x h.118</p>	<p>Lamp, painted metal structure. Lampshade covered with fabric and coupled to PVC. CE wiring blub max. 100 Watt E27. PVC electric wire.</p> <p>cm. l.30 x p.20 x h.118</p>	<p>Lampe, Struktur aus lackiertem Metall. Lampenschirm aus PVC, Stoff bezogen. CE-Verkabelung Birne max 100 Watt E27. Elektrischer Draht aus PVC.</p> <p>cm. l.30 x p.20 x h.118</p>	<p>Lampe, structure en métal verni, abat-jour revêtu en tissu couplé par PVC. Ampoule, câblage CE, max 100 Watt E27. Fil électrique en PVC.</p> <p>cm. l.30 x p.20 x h.118</p>
---	---	---	--	--

	<p>Carrè / Design E. Garbin M. Dell'Orto / pag. 248, 249</p> <p>Specchio bisellato. Pannello di supporto in MDF. Fissaggio a parete parte superiore e inferiore.</p> <p>cm l. 100 x h. 200 x p. 3 cm 120 x 120 x p. 3</p>	<p>Bevelled mirror. MDF support panel. Top and bottom wall fixing.</p> <p>cm l. 100 x h. 200 x p. 3 cm 120 x 120 x p. 3</p>	<p>Spiegel mit Abgeschrägter Rand. Trägertafel aus MDF. Wandinstallation: oben und unten.</p> <p>cm l. 100 x h. 200 x p. 3 cm 120 x 120 x p. 3</p>	<p>Miroir, chant biseauté. Panneau de support en MDF. Fixation au mur : partie supérieure et inférieure.</p> <p>cm l. 100 x h. 200 x p. 3 cm 120 x 120 x p. 3</p>
--	--	---	--	---

	<p>Specchio / Design E. Garbin M. Dell'Orto / pag. 250, 251</p> <p>Specchio, telaio in alluminio anodizzato. Pannello in MDF rivestito specchio.</p> <p>cm. l. 90 x h.190 x p.4 cm. 100 x 100 x p.4</p>	<p>Mirror, anodised aluminium frame. MDF panel covered in mirror.</p> <p>cm. l. 90 x h.190 x p.4 cm. 100 x 100 x p.4</p>	<p>Spiegel, Rahmen aus eloxiertem Aluminium, Trägertafel aus MDF, Spiegel bedeckt.</p> <p>cm. l. 90 x h.190 x p.4 cm. 100 x 100 x p.4</p>	<p>Miroir, cadre en aluminium anodisé, panneau en MDF revêtu en miroir.</p> <p>cm. l. 90 x h.190 x p.4 cm. 100 x 100 x p.4</p>
--	--	--	---	--

	<p>Vittoria / Design Paola Navone / pag. 253</p> <p>Specchio bisellato. Pannello in MDF rivestito specchio. Montaggio orizzontale / verticale</p> <p>cm. h.70 x l.50 x p.2,5 cm. h.80 x l.44 x p.2,5</p>	<p>Bevelled mirror. MDF panel covered in mirror. Fitting: vertical / horizontal</p> <p>cm. h.70 x l.50 x p.2,5 cm. h.80 x l.44 x p.2,5</p>	<p>Spiegel mit Abkantung. Trägertafel aus MDF, Spiegel bedeckt. Montage: horizontal / vertikal.</p> <p>cm. h.70 x l.50 x p.2,5 cm. h.80 x l.44 x p.2,5</p>	<p>Miroir avec biseaux. Panneau en MDF revêtu en miroir. Pose: verticale / horizontale.</p> <p>cm. h.70 x l.50 x p.2,5 cm. h.80 x l.44 x p.2,5</p>
--	---	--	--	--

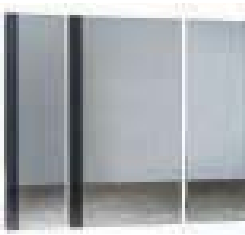
	<p>Reverso / Design Marco Boga / pag. 42, 163, 165, 255</p> <p>Specchio componibile con fascia in specchio fumè da 8 cm. Telaio in alluminio rivestito a specchio 45°. Pannello in MDF bilaminato. Montaggio orizzontale / verticale.</p> <p>cm. h. 200 x l. 100 x p. 4 cm. h. 200 x l. 70 x p. 4 cm. h. 200 x l. 50 x p. 4</p>	<p>Modular mirror with 8 cm. smoked glass band. Frame in aluminium covered with mirror, 45°. Panel in MDF, bi-laminated. Fitting: vertical / horizontal.</p> <p>cm. h. 200 x l. 100 x p. 4 cm. h. 200 x l. 70 x p. 4 cm. h. 200 x l. 50 x p. 4</p>	<p>Modularspiegel mit 8 cm Rauch-Spiegelrahmen. Rahmen aus Aluminium, Spiegel bedeckt, 45°. Platte aus MDF, bi-laminiert. Installation: horizontal / vertikal.</p> <p>cm. h. 200 x l. 100 x p. 4 cm. h. 200 x l. 70 x p. 4 cm. h. 200 x l. 50 x p. 4</p>	<p>Miroir modulaire, avec bande en miroir "fumé" de 8 cm. Panneau en MDF, revêtu en miroir, 45°. Panneau en MDF bi-laminé. Pose : verticale / horizontale.</p> <p>cm. h. 200 x l. 100 x p. 4 cm. h. 200 x l. 70 x p. 4 cm. h. 200 x l. 50 x p. 4</p>
---	--	--	--	--

	<p>Majestic / Design Paola Navone / pag. 259, 260</p> <p>Letto, struttura in pannelli particelle di legno. Imbottitura in poliuretano espanso. Piedi in massello di faggio tinto ebano (H. 12 cm.). Rivestimento: sfoderabile (tessuto) / fisso (pelle).</p> <p>cm. l. 170 x p. 214 x h. 38 / 140 (per rete da 160x200 e Q.S.) cm. l. 190 x p. 214 x h. 38 / 140 (per rete da 180x200) cm. l. 210 x p. 214 x h. 38 / 140 (per rete da 200x200 e K.S.)</p>	<p>Bed, structure in wooden particleboard panel. Upholstered in polyurethane foam. Feet in solid beech wood, ebony colour (H. 12 cm.). Removable cover (fabric) / fixed cover (leather).</p> <p>cm. l. 170 x p. 214 x h. 38 / 140 (for spring of cm.160x200 & Q.S.) cm. l. 190 x p. 214 x h. 38 / 140 (for spring of cm. 180x200) cm. l. 210 x p. 214 x h. 38 / 140 (for spring of cm. 200x200 & K.S.)</p>	<p>Bett, Struktur aus Holzspanplatte. Polsterung aus Polyurethanschaum. FüÙe aus massivem Buchenholz, Ebenfarbe (H. 12 cm.). Abnehmbarer Bezug (Stoff) / Fester Bezug (Leder).</p> <p>cm. l. 170 x p. 214 x h. 38 / 140 (für Lattenrost cm.160x200 & Q.S.) cm. l. 190 x p. 214 x h. 38 / 140 (für Lattenrost cm. 180x200) cm. l. 210 x p. 214 x h. 38 / 140 (für Lattenrost cm. 200x200 & K.S.)</p>	<p>Lit, structure en panneau de particules de bois. Rembourrage en mousse de polyuréthane. Pieds en hêtre massif, ton ébène (H. 12 cm.). Revêtement: déhoussable (tissu) / non déhoussable (cuir).</p> <p>cm. l. 170 x p. 214 x h. 38 / 140 (pour sommier de cm 160x200 et Q.S.) cm. l. 190 x p. 214 x h. 38 / 140 (pour sommier de cm 180x200) cm. l. 210 x p. 214 x h. 38 / 140 (pour sommier de cm 200x200 et K.S.)</p>
--	--	---	---	--

	<p>Westin / Design Paola Navone / pag. 263, 264</p> <p>Letto, struttura in pannelli particelle di legno. Imbottitura in poliuretano espanso. Piedi in massello di faggio tinto ebano (H. 12 cm.). Rivestimento: sfoderabile (tessuto) / fisso (pelle).</p> <p>cm. l. 183 x p. 214 x h. 38 / 117 (per rete da 160x200 e Q.S.) cm. l. 203 x p. 214 x h. 38 / 117 (per rete da 180x200) cm. l. 223 x p. 214 x h. 38 / 117 (per rete da 200x200 e K.S.)</p>	<p>Bed, structure in wooden particleboard panel. Upholstered in polyurethane foam. Feet in solid beech wood, ebony colour (H. 12 cm.). Removable cover (fabric) / fixed cover (leather).</p> <p>cm. l. 183 x p. 214 x h. 38 / 117 (for spring of cm.160x200 & Q.S.) cm. l. 203 x p. 214 x h. 38 / 117 (for spring of cm. 180x200) cm. l. 223 x p. 214 x h. 38 / 117 (for spring of cm. 200x200 & K.S.)</p>	<p>Bett, Struktur aus Holzspanplatte. Polsterung aus Polyurethanschaum. FüÙe aus massivem Buchenholz, Ebenfarbe (H. 12 cm.). Abnehmbarer Bezug (Stoff) / Fester Bezug (Leder).</p> <p>cm. l. 183 x p. 214 x h. 38 / 117 (für Lattenrost cm.160x200 & Q.S.) cm. l. 203 x p. 214 x h. 38 / 117 (für Lattenrost cm. 180x200) cm. l. 223 x p. 214 x h. 38 / 117 (für Lattenrost cm. 200x200 & K.S.)</p>	<p>Lit, structure en panneau de particules de bois. Rembourrage en mousse de polyuréthane. Pieds en hêtre massif, ton ébène (H. 12 cm.). Revêtement: déhoussable (tissu) / non déhoussable (cuir).</p> <p>cm. l. 183 x p. 214 x h. 38 / 117 (pour sommier de cm 160x200 et Q.S.) cm. l. 203 x p. 214 x h. 38 / 117 (pour sommier de cm 180x200) cm. l. 223 x p. 214 x h. 38 / 117 (pour sommier de cm 200x200 et K.S.)</p>
--	--	--	---	--

	<p>Astoria / Design Paola Navone / pag. 267, 269</p> <p>Letto, struttura in pannelli particelle di legno. Imbottitura in poliuretano espanso. Piedi in massello di faggio tinto ebano (H. 12 cm.). Rivestimento: sfoderabile (tessuto) / fisso (pelle).</p> <p>cm. l. 230 x p. 214 x h. 38 / 102 (per rete da 160x200 e Q.S.) cm. l. 250 x p. 214 x h. 38 / 102 (per rete da 180x200) cm. l. 270 x p. 214 x h. 38 / 102 (per rete da 200x200 e K.S.)</p>	<p>Bed, structure in wooden particleboard panel. Upholstered in polyurethane foam. Feet in solid beech wood, ebony colour (H. 12 cm.). Removable cover (fabric) / fixed cover (leather).</p> <p>cm. l. 230 x p. 214 x h. 38 / 102 (for spring of cm.160x200 & Q.S.) cm. l. 250 x p. 214 x h. 38 / 102 (for spring of cm. 180x200) cm. l. 270 x p. 214 x h. 38 / 102 (for spring of cm. 200x200 & K.S.)</p>	<p>Bett, Struktur aus Holzspanplatte. Polsterung aus Polyurethanschaum. FüÙe aus massivem Buchenholz, Ebenfarbe (H. 12 cm.). Abnehmbarer Bezug (Stoff) / Fester Bezug (Leder).</p> <p>cm. l. 230 x p. 214 x h. 38 / 102 (für Lattenrost cm.160x200 & Q.S.) cm. l. 250 x p. 214 x h. 38 / 102 (für Lattenrost cm. 180x200) cm. l. 270 x p. 214 x h. 38 / 102 (für Lattenrost cm. 200x200 & K.S.)</p>	<p>Lit, structure en panneau de particules de bois. Rembourrage en mousse de polyuréthane. Pieds en hêtre massif, ton ébène (H. 12 cm.). Revêtement: déhoussable (tissu) / non déhoussable (cuir).</p> <p>cm. l. 230 x p. 214 x h. 38 / 102 (pour sommier de cm 160x200 et Q.S.) cm. l. 250 x p. 214 x h. 38 / 102 (pour sommier de cm 180x200) cm. l. 270 x p. 214 x h. 38 / 102 (pour sommier de cm 200x200 et K.S.)</p>
---	---	--	---	--

	<p>Vanity / Design Castello Lagravinese / pag. 271, 273</p> <p>Letto, testata in massello di abete e multistrato di pioppo. Base pannelli di particelle legno. Piedi in ABS. Imbottitura in poliuretano espanso. Rivestimento fisso.</p> <p>cm. l.240 x p.240 x h.32/120 (per rete da 160x200 e Q.S.) cm. l.260 x p.240 x h.32/120 (per rete da 180x200) cm. l.280 x p.240 x h.32/120 (per rete da 200x200 e K.S.)</p>	<p>Bed, headboard in solid pinewood and multi ply of poplar. Base: wooden particleboard panels. ABS feet. Upholstered in polyurethane foam. Fixed cover.</p> <p>cm. l.240 x p.240 x h.32/105 (for Spring of cm 160x200 & Q.S.) cm. l.360 x p.240 x h.32/105 (for spring of cm 180x200) cm. l.380 x p.240 x h.32/105 (for spring of cm 200x200 & K.S.)</p>	<p>Bett, Kopfteil aus massivem Tannenholz und Pappelmultiplexplatte. Basis aus Holzspanplatte. FüÙe aus ABS. Polsterung aus Polyurethanschaum. Fester Bezug.</p> <p>cm. l.240 x p.240 x h.32/105 (für Lattenrost cm 160x200 & Q.S.) cm. l.360 x p.240 x h.32/105 (für Lattenrost cm 180x200) cm. l.380 x p.240 x h.32/105 (für Lattenrost cm 200x200 & K.S.)</p>	<p>Lit, tête du lit en sapin massif et multiplis de peuplier. Base: panneau de particules de bois. Pieds en ABS. Rembourrage en mousse de polyuréthane. Revêtement non déhoussable.</p> <p>cm. l.240 x p.240 x h.32/105 (pour sommier de cm 160x200 et Q.S.) cm. l.360 x p.240 x h.32/105 (pour sommier de cm 180x200) cm. l.380 x p.240 x h.32/105 (pour sommier de cm 200x200 et K.S.)</p>
---	---	---	--	--

	<p>Royale capitoné / Design Castello Lagravinese / pag. 275, 277</p> <p>Letto, testata capitoné in massello di abete, multistrato di pino e MDF. Base pannelli di particelle legno. Piedi in ABS. Imbottitura in poliuretano espanso. Rivestimento fisso.</p> <p>cm. l.340 x p.240 x h.32/105 (per rete da 160x200 e Q.S.) cm. l.360 x p.240 x h.32/105 (per rete da 180x200) cm. l.380 x p.240 x h.32/105 (per rete da 200x200 e K.S.)</p>	<p>Bed, capitoné tufted headboard in solid pinewood, multi ply of pinewood and MDF. Base: wooden particleboard panel. ABS feet. Upholstered in polyurethane foam. Fixed cover.</p> <p>cm. l.340 x p.240 x h.32/105 (für Spring of cm 160x200 & Q.S.) cm. l.360 x p.240 x h.32/105 (für spring of cm 180x200) cm. l.380 x p.240 x h.32/105 (für spring of cm 200x200 & K.S.)</p>	<p>Bett, Capitoné Kopfteil aus massivem Tannenholz, Kiefermultiplexplatte und MDF. Basis aus Holzspanplatte. FüÙe aus ABS. Polsterung aus Polyurethanschaum. Fester Bezug.</p> <p>cm. l.340 x p.240 x h.32/105 (für Lattenrost cm 160x200 & Q.S.) cm. l.360 x p.240 x h.32/105 (für Lattenrost cm 180x200) cm. l.380 x p.240 x h.32/105 (für Lattenrost cm 200x200 & K.S.)</p>	<p>Lit, tête du lit capitonée en sapin massif, multiplis de pin et MDF. Base: panneau de particules de bois. Pieds en ABS. Rembourrage en mousse de polyuréthane. Revêtement non déhoussable.</p> <p>cm. l.340 x p.240 x h.32/105 (pour sommier de cm 160x200 et Q.S.) cm. l.360 x p.240 x h.32/105 (pour sommier de cm 180x200) cm. l.380 x p.240 x h.32/105 (pour sommier de cm 200x200 et K.S.)</p>
---	--	---	--	--

	<p>Royale / Design Castello Lagravinese / pag. 279</p> <p>Letto, testata in massello di abete, multistrato di pino e MDF. Base pannelli di particelle legno. Piedi in ABS. Imbottitura in poliuretano espanso. Rivestimento fisso.</p> <p>cm. l.340 x p.240 x h.32/105 (per rete da 160x200 e Q.S.) cm. l.360 x p.240 x h.32/105 (per rete da 180x200) cm. l.380 x p.240 x h.32/105 (per rete da 200x200 e K.S.)</p>	<p>Bed, headboard in solid pinewood, multi ply of pinewood and MDF. Base: wooden particleboard panel. ABS feet. Upholstered in polyurethane foam. Fixed cover.</p> <p>cm. l.340 x p.240 x h.32/105 (for Spring of cm 160x200 & Q.S.) cm. l.360 x p.240 x h.32/105 (for spring of cm 180x200) cm. l.380 x p.240 x h.32/105 (for spring of cm 200x200 & K.S.)</p>	<p>Bett, Kopfteil aus massivem Tannenholz, Kiefermultiplexplatte und MDF. Basis aus Holzspanplatte. FüÙe aus ABS. Polsterung aus Polyurethanschaum. Fester Bezug.</p> <p>cm. l.340 x p.240 x h.32/105 (für Lattenrost cm 160x200 & Q.S.) cm. l.360 x p.240 x h.32/105 (für Lattenrost cm 180x200) cm. l.380 x p.240 x h.32/105 (für Lattenrost cm 200x200 & K.S.)</p>	<p>Lit, tête du lit en sapin massif, multiplis de pin et MDF. Base: panneau de particules de bois. Pieds en ABS. Rembourrage en mousse de polyuréthane. Revêtement non déhoussable.</p> <p>cm. l.340 x p.240 x h.32/105 (pour sommier de cm 160x200 et Q.S.) cm. l.360 x p.240 x h.32/105 (pour sommier de cm 180x200) cm. l.380 x p.240 x h.32/105 (pour sommier de cm 200x200 et K.S.)</p>
---	---	---	---	--

	<p>Pilloipe / Design Paola Navone / pag. 281</p> <p>Letto, testata in massello di abete e MDF, base pannelli di particelle legno. Piedi in ABS. Imbottitura in poliuretano espanso. Rivestimento sfoderabile (tessuto) / fisso (pelle).</p> <p>cm. l.200 x p.220 x h.32/130 (per rete da 160x200 e Q.S.) cm. l.220 x p.220 x h.32/130 (per rete da 180x200) cm. l.240 x p.220 x h.32/130 (per rete da 200x200 e K.S.)</p>	<p>Bed, headboard in solid pinewood and MDF. Base: wooden particleboard panel. ABS feet. Upholstered in polyurethane foam. Removable cover (fabric) / fixed cover (leather).</p> <p>cm. l.200 x p.220 x h.32/130 (for Spring of cm 160x200 & Q.S.) cm. l.220 x p.220 x h.32/130 (for spring of cm 180x200) cm. l.240 x p.220 x h.32/130 (for spring of cm 200x200 & K.S.)</p>	<p>Bett, Kopfteil: aus massivem Tannenholz und MDF. Basis: Holzspanplatte. FüÙe aus ABS. Polsterung aus Polyurethanschaum. Abnehmbarer Bezug (Stoff) / Fester Bezug (Leder).</p> <p>cm. l.200 x p.220 x h.32/130 (für Lattenrost cm 160x200 & Q.S.) cm. l.220 x p.220 x h.32/130 (für Lattenrost cm 180x200) cm. l.240 x p.220 x h.32/130 (für Lattenrost cm 200x200 & K.S.)</p>	<p>Lit, tête du lit en sapin massif et MDF. Base: panneau de particules de bois. Pieds en ABS. Rembourrage en mousse de polyuréthane. Revêtement déhoussable (tissu) / non déhoussable (cuir).</p> <p>cm. l.200 x p.220 x h.32/130 (pour sommier de cm 160x200 et Q.S.) cm. l.220 x p.220 x h.32/130 (pour sommier de cm 180x200) cm. l.240 x p.220 x h.32/130 (pour sommier de cm 200x200 et K.S.)</p>
---	--	---	--	---

	<p>Jacopo / Design Casamitano / pag. 283</p> <p>Letto, testata capitoné in massello di abete e MDF. Base pannelli di particelle legno. Piedi in ABS. Imbottitura in poliuretano espanso. Rivestimento fisso.</p> <p>cm. l.180 x p.220 x h.32/115 (per rete da 160x200 e Q.S.) cm. l.200 x p.220 x h.32/115 (per rete da 180x200) cm. l.220 x p.220 x h.32/115 (per rete da 200x200 e K.S.)</p>	<p>Bed, capitoné tufted headboard in solid pinewood and MDF. Base: wooden particleboard panel. ABS feet. Upholstered in polyurethane foam. Fixed cover.</p> <p>cm. l.180 x p.220 x h.32/115 (for Spring of cm 160x200 & Q.S.) cm. l.200 x p.220 x h.32/115 (for spring of cm 180x200) cm. l.220 x p.220 x h.32/115 (for spring of cm 200x200 & K.S.)</p>	<p>Bett, Capitoné Kopfteil aus massivem Tannenholz und MDF. Basis aus Holzspanplatte. FüÙe aus ABS. Polsterung aus Polyurethanschaum. Fester Bezug.</p> <p>cm. l.180 x p.220 x h.32/115 (für Lattenrost cm 160x200 & Q.S.) cm. l.200 x p.220 x h.32/115 (für Lattenrost cm 180x200) cm. l.220 x p.220 x h.32/115 (für Lattenrost cm 200x200 & K.S.)</p>	<p>Lit, tête du lit capitonée en sapin massif et MDF. Base: panneau de particules de bois. Pieds en MDF. Rembourrage en mousse de polyuréthane. Revêtement non déhoussable.</p> <p>cm. l.180 x p.220 x h.32/115 (pour sommier de cm 160x200 et Q.S.) cm. l.200 x p.220 x h.32/115 (pour sommier de cm 180x200) cm. l.220 x p.220 x h.32/115 (pour sommier de cm 200x200 et K.S.)</p>
---	---	--	---	--

Legno / Wood / Holz / Bois



Smoky oak

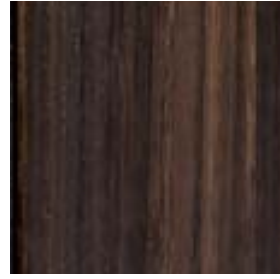

Eucalipto termo-trattato
Heat-treated eucalyptus
Wärmebehandeltes Eukalyptus
Eucalyptus traité thermiquement



Rovere tinto ebano
Oak stained to ebony
Ebenfarben gebeizte Eiche
Chêne ton èbène



Rovere tinto moka
Oak stained to moka
Mokafarben gebeizte Eiche
Chêne ton moka



Rovere tinto grigio
Oak stained to grey
Graufarben gebeizte Eiche
Chêne ton gris

Legno / Wood / Holz / Bois



Rovere naturale
Natural oak
Natürliche Eiche
Chêne naturel



Sottsass grey

Finitura / Finish / Ausführung / Finition



Peltro
(wood / metal)



Ottobronze
(wood / metal)

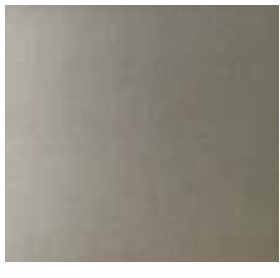

Platino
(metal)

Laccato / Lacquered / Lackiert / Laqué

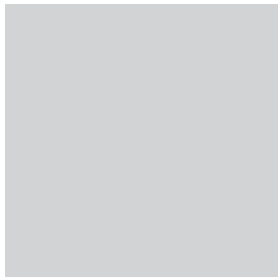

Greige RAL 7044



SAND NCS 2005Y 40 R

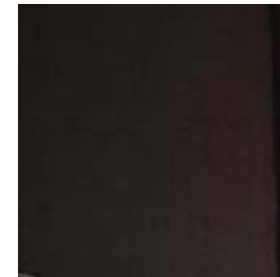

Marrone nerastro RAL 8022

Vetro retro verniciato / Glass painted on the back / hinter lackierter Glas / Verre verni au derrière

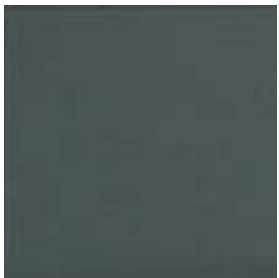

RAL 7016 antracite

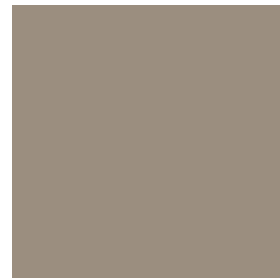

RAL 1019 beige grigiastro



RAL 9004 nero

Marmo / Marble / Marmor / Marbre



Calacatta oro (Italy)



Arabescato grigio (Italy)



Arabescato viola (Italy)



Carrara Gioia bianco (Italy)



Rosso lepanto (Turkey)



Damasco (Turkey)



Nero Marquinia (Spain)

Marmo / Marble / Marmor / Marbre



Patagonia (Brazil)

Marmo / Marble / Marmor / Marbre



Dover white (Africa)

Art direction Anna Turati

Styling Bruno Tarsia

Photo Lorenzo Pennati

Printed in Italy April 2019 / © Casamilano by Grafiche Antiga SpA

Thanks to:

Adriano Caverzasio – Ahura ceramiche e porcellane – Alessi – Alidem, l'arte della fotografia - Andrea Brandi - Arcahorn – Argenesi – Arnolfo di Cambio – Arte9Milano – Arteriors -
Augusto Garavaglia – AYTM - Barazzoni - B.H.Italy srl – Bitossi Ceramiche - Bosa – Botteganove – Cctapis – Cedes Milano – CEDIT Ceramiche d'Italia (made in Florim) -
Ceramiche Rometti - Christofle - Corrado Corradi - De Vecchi – Diamantini & Domeniconi – Ditta Barile Biagio - Dôme Deco – Effeitalia – Egizia - Elleffe Design
- Erba – ferm-LIVING distr. da trend-HOUSE - Francesco Battaglini - Francesco della Femina – Galleria Fatto ad Arte - Galleria Michela Cattai –
Giacomo Rossi -Giuliano Cataldo Giancotti – Ghidini 1961 – Giobagnara - Golran – Greggio argenterie - Hammerfest – Hands on Design - Henriette – Illulian - Incipit- IVV – Jab - Kasthall – Lamart – Leo
Dainelli - Leonardo - LF Design - Livellara - Lladrò - MADE4ART - Milano | Artworks by Giancarlo Fabbi - Gianni Oliva – Mambo Unlimited Ideas – Mani Ceramics by Britta Herrmann -
Marco Fattori – Marco Ripa Fabbro Atipico - Maria Pellini - MarinaC - Mario Cioni & C.- Marioni – Martini Spa Il Coccio Design Edition -M&G Redaelli courtesy of Galleria Spazioporpora
Mason Editions - Masserano Cashmere - Mepra - Milia Seyppel – Mirabello Carrara -
Montegrappa – Nando Stevoli, courtesy of Lattuada Studio - Nude - Nuova Galleria Morone - Ottaviani – Petri Firenze - Pinetti - Pratesi - Quagliotti - Raffaele Barbuto - Raffaele Zuccheri - Ranoldi –
Republic of Fritz Hansen - Riviere - Rosenthal -Sahrai - Salvati - Sambonet - Sara Montani – Scandola Marmi - Secon dome - Sitap Carpet Couture Italia – SkIO Studio – Skultuna 1607- Something Good
– Somma - Stefano Pugliese – Stories of Italy - Studio di architettura Luca Scacchetti - Vanessa Mitrani – Vano Alto – Villeroy & Boch, Arti della Tavola – Zonca