

| | |
|----------------|-----|
| Living | 6 |
| Dining | 75 |
| Home Office | 90 |
| Night | 94 |
| Walk-in Closet | 112 |
| Others | 114 |
| Finishes | 156 |
| Marbles | 176 |

Ventura

DIVANO COMPONIBILE - SECTIONAL SOFA

Linear - 00305 - l. 352 x p. 90 x h. 84 cm

Divano componibile con struttura in multistrati e acciaio, rivestimento cuscini seduta con gomme di varie densità, strato superiore in Memory, ricoperto da una soffice falda di piuma d'oca su tutta la superficie. Cuscini schienale in piuma d'oca. Seduta con cinghie elastiche da 6 cm. Piedi in acciaio finitura nero opaco.

Modular sofa with plywood structure, seat cushions covered in multi-density rubber, upper layer in Memory foam, all-over surface of soft goose down. Backrest cushions of goose down. Seat with 6 cm elastic belts. Steel feet with opaque black finish.

PAG.
Vol.1 - 12, 13, 15, 16, 17, 18, 19, 20, 21, 22, 23, 24, 27

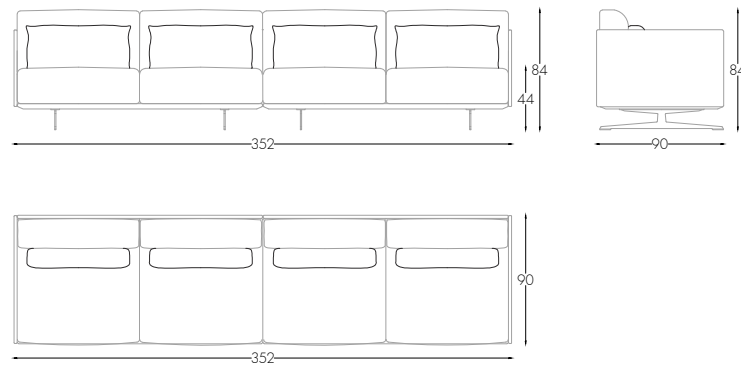

Ventura

DIVANO COMPONIBILE - SECTIONAL SOFA

Linear - 00307 - l. 373 x p. 170 x h. 84 cm

Divano componibile con struttura in multistrati e acciaio, rivestimento cuscini seduta con gomme di varie densità, strato superiore in Memory, ricoperto da una soffice falda di piuma d'oca su tutta la superficie. Cuscini schienale in piuma d'oca. Seduta con cinghie elastiche da 6 cm. Piedi in acciaio finitura nero opaco.

Modular sofa with plywood structure, seat cushions covered in multi-density rubber, upper layer in Memory foam, all-over surface of soft goose down. Backrest cushions of goose down. Seat with 6 cm elastic belts. Steel feet with opaque black finish.

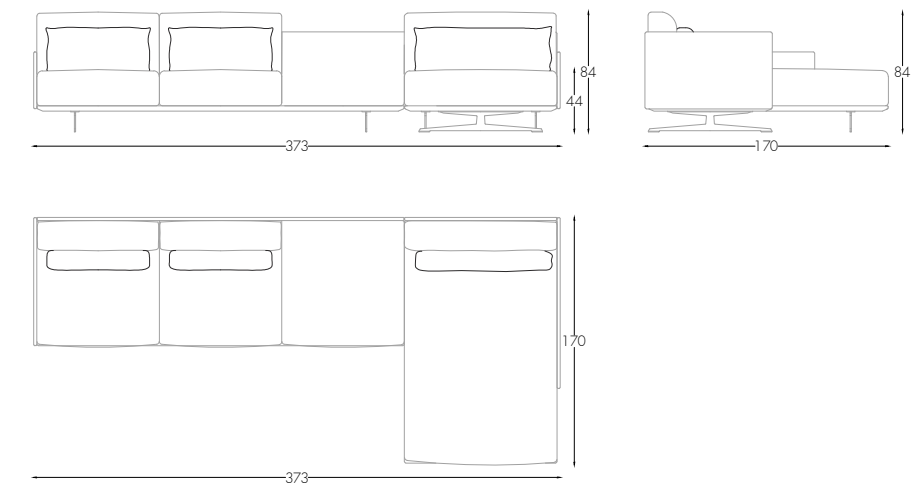

Ventura

DIVANO COMPONIBILE - SECTIONAL SOFA

Linear - 00306 - l. 286 x p. 170 x h. 84 cm

Divano componibile con struttura in multistrati e acciaio, rivestimento cuscini seduta con gomme di varie densità, strato superiore in Memory, ricoperto da una soffice falda di piuma d'oca su tutta la superficie. Cuscini schienale in piuma d'oca. Seduta con cinghie elastiche da 6 cm. Piedi in acciaio finitura nero opaco.

Modular sofa with plywood structure, seat cushions covered in multi-density rubber, upper layer in Memory foam, all-over surface of soft goose down. Backrest cushions of goose down. Seat with 6 cm elastic belts. Steel feet with opaque black finish.

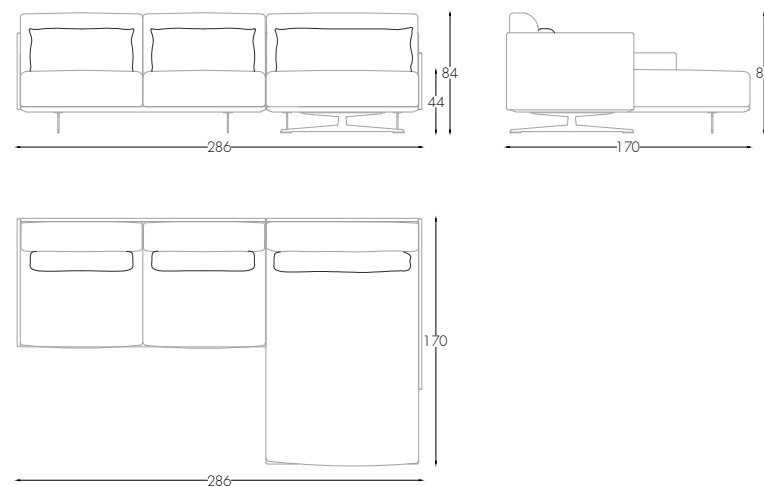

Ventura

DIVANO COMPONIBILE - SECTIONAL SOFA

Angular - 00248 - l. 460x p. 353 x p. 170 x h. 84 cm

Divano componibile con struttura in multistrati e acciaio, rivestimento cuscini seduta con gomme di varie densità, strato superiore in Memory, ricoperto da una soffice falda di piuma d'oca su tutta la superficie. Cuscini schienale in piuma d'oca. Seduta con cinghie elastiche da 6 cm. Piedi in acciaio finitura nero opaco.

Modular sofa with plywood structure, seat cushions covered in multi-density rubber, upper layer in Memory foam, all-over surface of soft goose down. Backrest cushions of goose down. Seat with 6 cm elastic belts. Steel feet with opaque black finish.

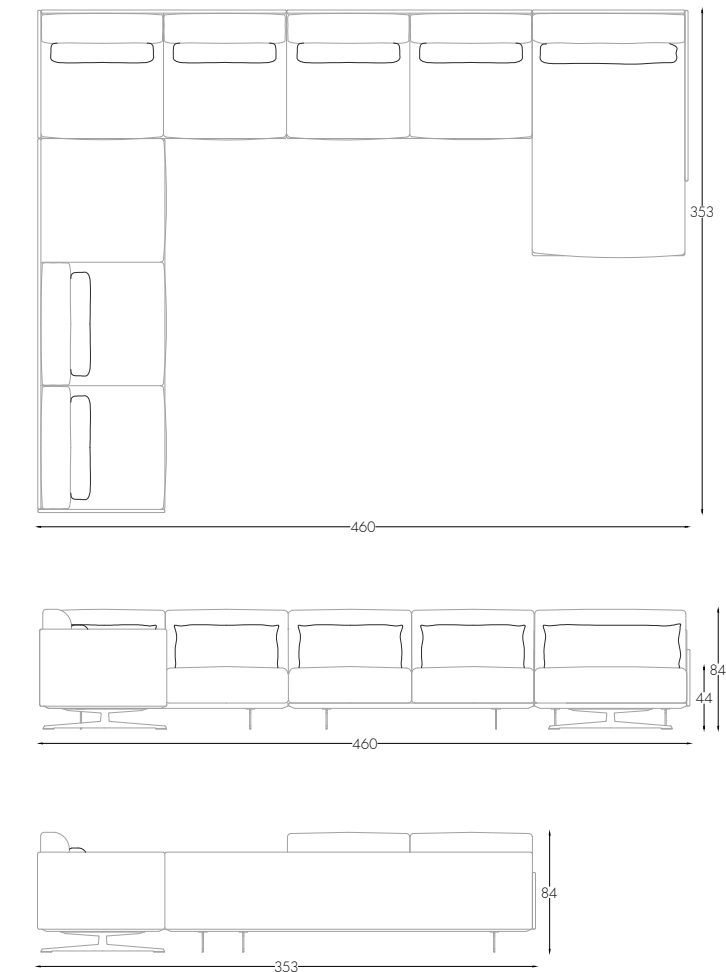

Alexander

DIVANO COMPONIBILE - SECTIONAL SOFA

Linear - 00016 - l. 284 x p. 100 x h. 78 cm
 Linear - 00016/P - l. 200 x p. 100 x h. 78 cm
 Angular - 00016/G - l. 284/370 x p. 100 x h 78 cm

Divano componibile con struttura in multistrati, rivestimento con gomme di varie densità, strato superiore in air soft ricoperto da una soffice falda di piuma d'oca su tutta la superficie. Strato superiore di cuscini e seduta con gomma Memory di 3 cm. Seduta con cinghie elastiche da 6 cm. Rivestimento su bracciolo con trapuntatura a rombi.

Modular sofa with plywood structure, covered with multi-density rubbers, upper layer in air soft, covered with a soft layer of goose down over the entire surface. Top layer of cushions and seat in 3 cm Memory rubber. Seat with 6 cm elastic belts. Diamond-quilted upholstery on the armrests.

PAG.
 Vol.1 - 170, 171, 172, 173, 174, 224, 225

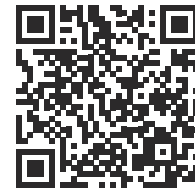
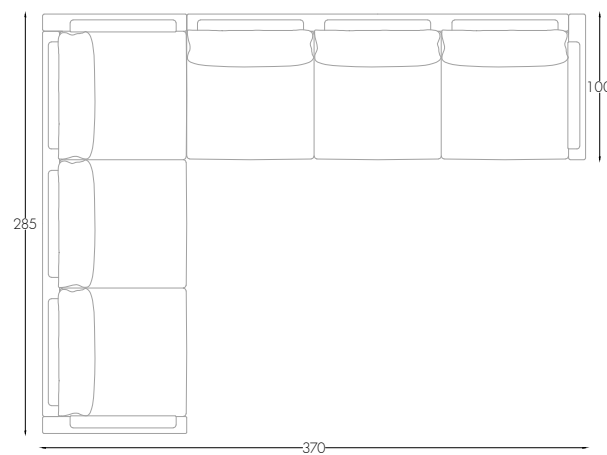
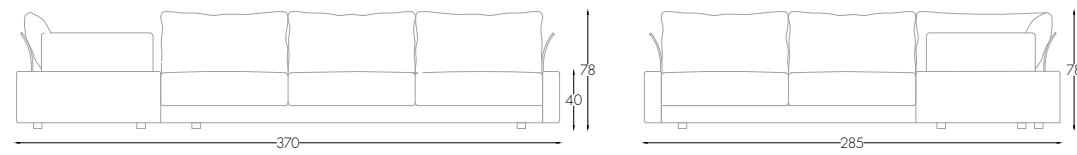
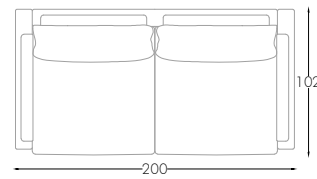
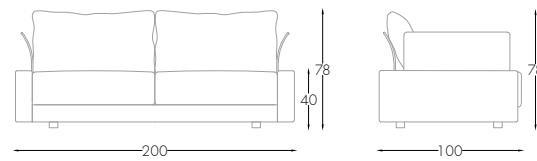
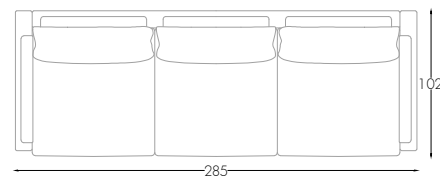
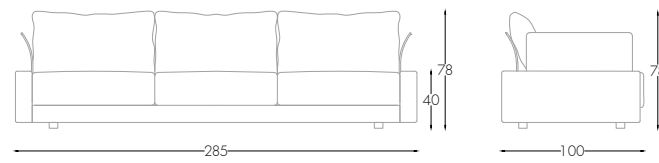

Montecarlo

DIVANO COMPONIBILE CURVO - SECTIONAL CURVED SOFA

00092 - l. 245 x p. 100 x h. 85 cm

Divano componibile con struttura in multistrati, rivestimento con gomme di varie densità, strato superiore in air soft ricoperto da una soffice falda di piuma d'oca su tutta la superficie. Strato superiore di cuscini e seduta con gomma Memory di 3 cm. Seduta con cinghie elastiche da 6 cm. Elemento di collegamento in multistrati con foderina noce dark e finitura lucida spazzolata. cassetto interno con guide blu-motion, apertura push-pull.

Modular sofa with plywood structure, covered with multi-density rubbers, upper layer in air soft, covered with a soft layer of goose down over the entire surface. Top layer of cushions and seat in 3 cm Memory rubber. Seat with 6 cm elastic belts. Linking element in plywood structure with canaletto walnut veneer and brushed gloss finish. Internal drawer with blumotion runners, push-pull opening.

PAG.
 Vol.1 - 230, 231, 235, 236, 238

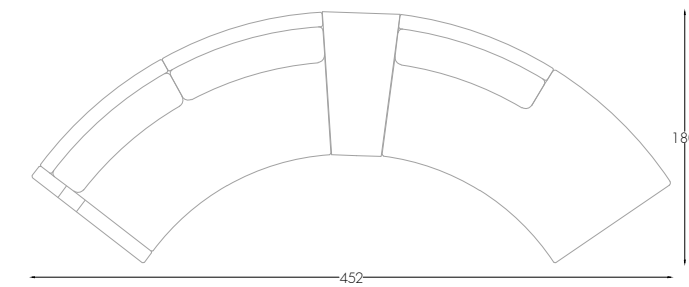
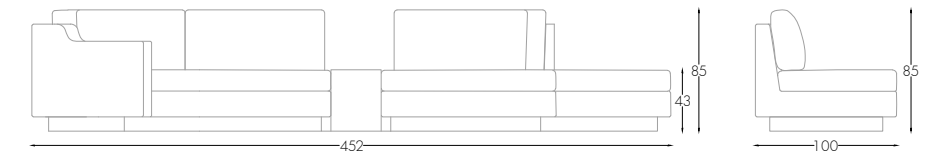

Montecarlo

DIVANO COMPONIBILE CURVO - SECTIONAL CURVED SOFA

00092/X - l. 530 x p. 235 x h. 85 cm

Divano componibile con struttura in multistrati, rivestimento con gomme di varie densità, strato superiore in air soft ricoperto da una soffice falda di piuma d'oca su tutta la superficie. Strato superiore di cuscini e seduta con gomma Memory di 3 cm. Seduta con cinghie elastiche da 6 cm. Elemento di collegamento in multistrati con foderina noce dark e finitura lucida spazzolata. cassetto interno con guide blu-motion, apertura push-pull.

Modular sofa with plywood structure, covered with multi-density rubbers, upper layer in air soft, covered with a soft layer of goose down over the entire surface. Top layer of cushions and seat in 3 cm Memory rubber. Seat with 6 cm elastic belts. Linking element in plywood structure with canaletto walnut veneer and brushed gloss finish. Internal drawer with blumotion runners, push-pull opening.

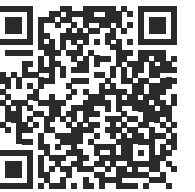
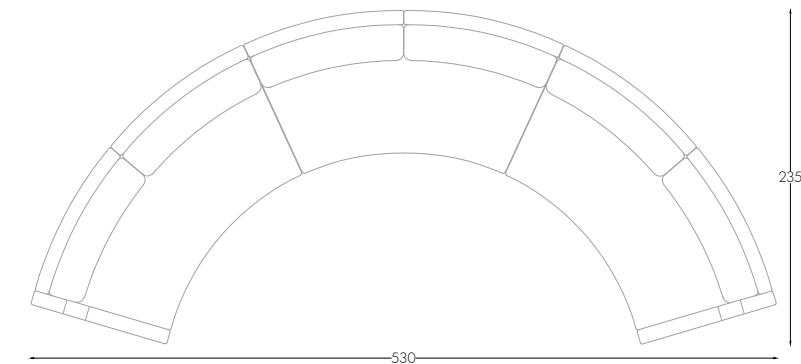

Montecarlo

DIVANO componibile CURVO - SECTIONAL
CURVED SOFA

00092/Y - l. 550 x p. 321 x h. 85 cm

Divano componibile con struttura in multistrati, rivestimento con gomme di varie densità, strato superiore in air soft ricoperto da una soffice falda di piuma d'oca su tutta la superficie. Strato superiore di cuscini e seduta con gomma Memory di 3 cm. Seduta con cinghie elastiche da 6 cm. Elemento di collegamento in multistrati con foderina noce dark e finitura lucida spazzolata. cassetto interno con guide blu-motion, apertura push-pull.

Modular sofa with plywood structure, covered with multi-density rubbers, upper layer in air soft, covered with a soft layer of goose down over the entire surface. Top layer of cushions and seat in 3 cm Memory rubber. Seat with 6 cm elastic belts. Linking element in plywood structure with canaletto walnut veneer and brushed gloss finish. Internal drawer with blumotion runners, push-pull opening.

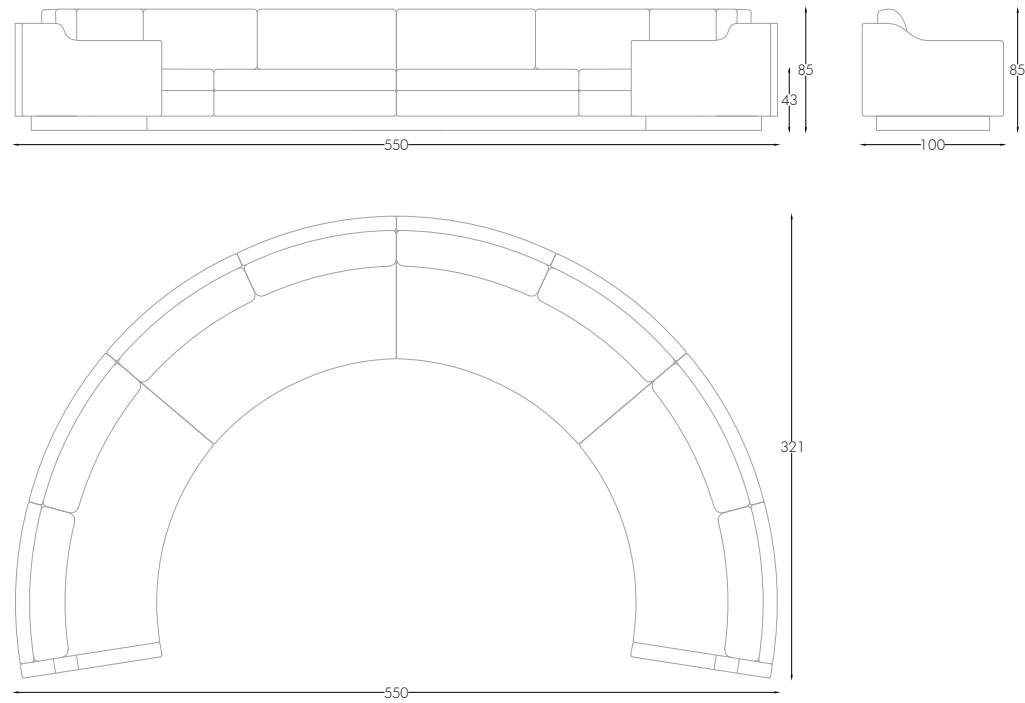

Alabama

DIVANO componibile - SECTIONAL SOFA

Linear - 00308 - l. 374/391 x p. 100/116 x h. 82 cm

Divano componibile con struttura in multistrati, struttura dei braccioli in metallo da 5mm rivestiti in cuoio, rivestimento cuscini seduta con gomme di varie densità, strato superiore in Memory, ricoperto da una soffice falda di piuma d'oca su tutta la superficie. Cuscini schienale in piuma d'oca. Seduta con cinghie elastiche da 6 cm.

Modular sofa with plywood structure, 5 mm metal arms covered in leather, cushion seat lined with multi-density rubber, upper layer in Memory foam, all-over soft goose down. Backrest cushions of goose down. Seat with 6 cm elastic belts.

PAG.
Vol.1 - 76, 77, 78, 79, 80, 81, 82, 83

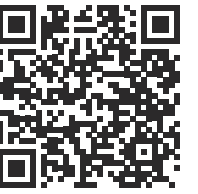
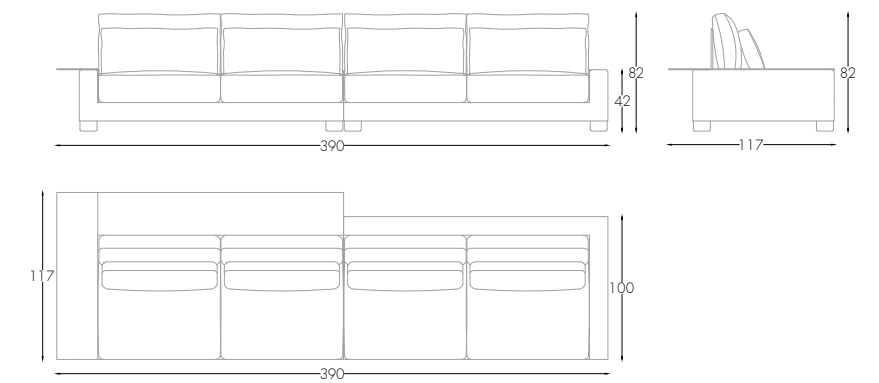

Montecarlo

DIVANO componibile CURVO - SECTIONAL
CURVED SOFA

00092/Z - l. 550 x p. 321 x h. 85 cm

Divano componibile con struttura in multistrati, rivestimento con gomme di varie densità, strato superiore in air soft ricoperto da una soffice falda di piuma d'oca su tutta la superficie. Strato superiore di cuscini e seduta con gomma Memory di 3 cm. Seduta con cinghie elastiche da 6 cm. Elemento di collegamento in multistrati con foderina noce dark e finitura lucida spazzolata. cassetto interno con guide blu-motion, apertura push-pull.

Modular sofa with plywood structure, covered with multi-density rubbers, upper layer in air soft, covered with a soft layer of goose down over the entire surface. Top layer of cushions and seat in 3 cm Memory rubber. Seat with 6 cm elastic belts. Linking element in plywood structure with canaletto walnut veneer and brushed gloss finish. Internal drawer with blumotion runners, push-pull opening.

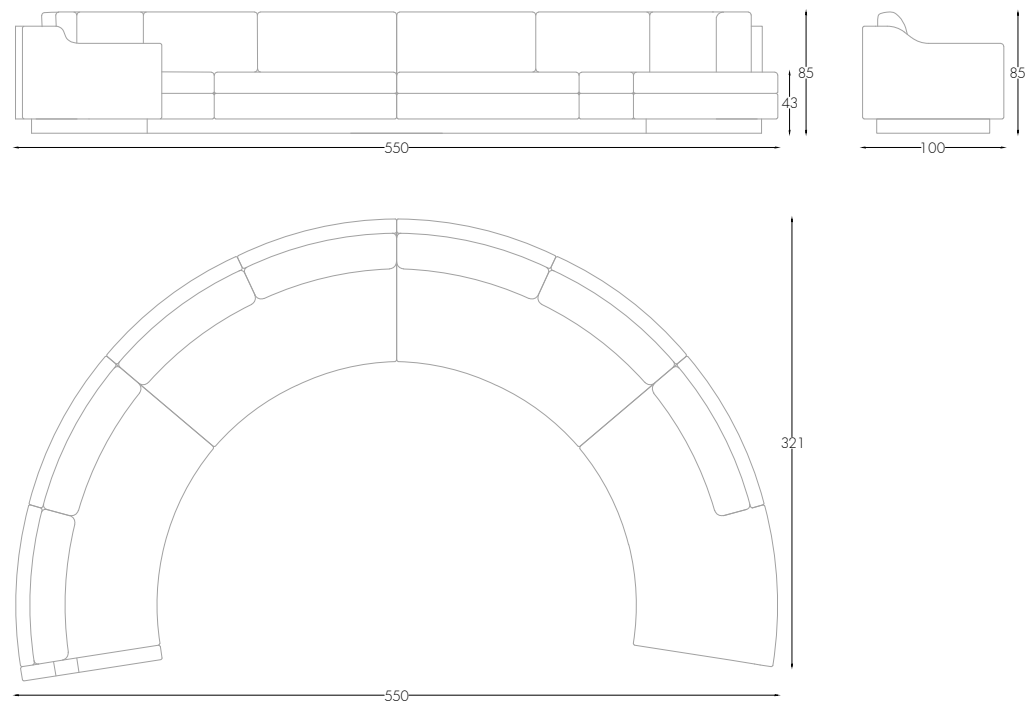

Alabama

DIVANO componibile - SECTIONAL SOFA

Angular - 00297 - l. 474 x p. 390 x p. 170 x h 82 cm

Divano componibile con struttura in multistrati, struttura dei braccioli in metallo da 5mm rivestiti in cuoio, rivestimento cuscini seduta con gomme di varie densità, strato superiore in Memory, ricoperto da una soffice falda di piuma d'oca su tutta la superficie. Cuscini schienale in piuma d'oca. Seduta con cinghie elastiche da 6 cm.

Modular sofa with plywood structure, 5 mm metal arms covered in leather, cushion seat lined with multi-density rubber, upper layer in Memory foam, all-over soft goose down. Backrest cushions of goose down. Seat with 6 cm elastic belts.

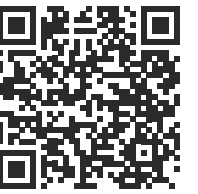
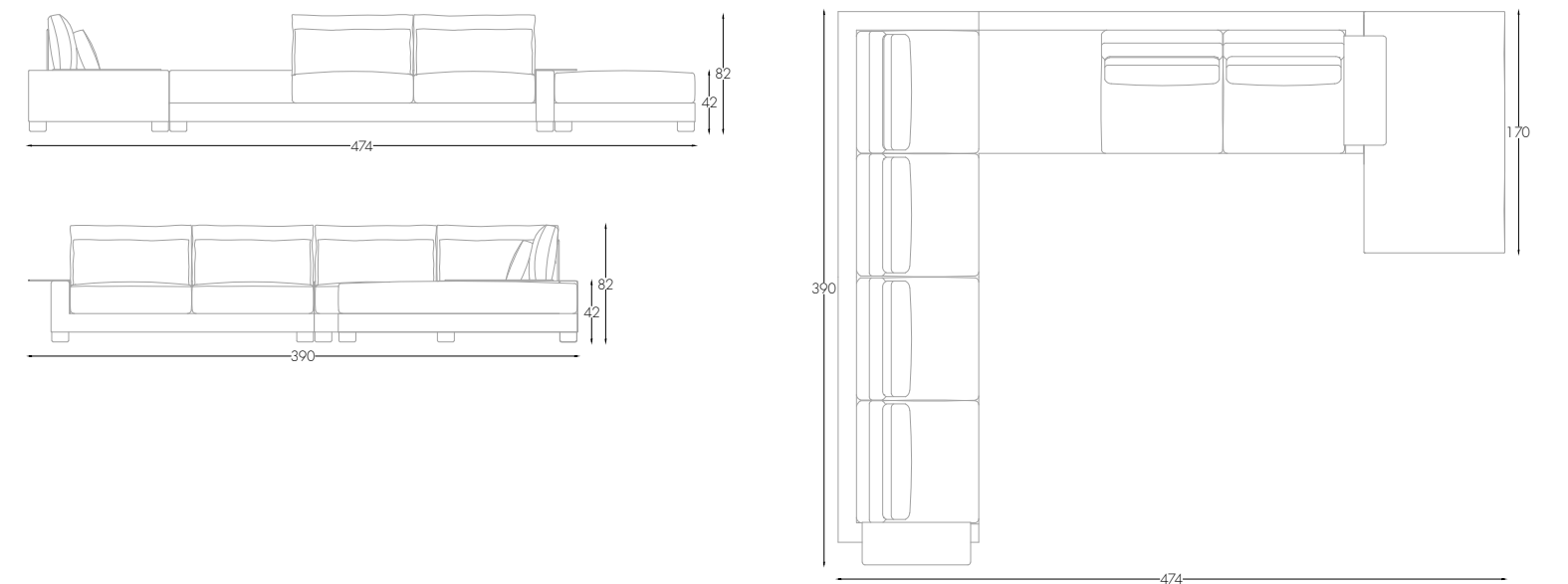

Santa Cruz

DIVANO COMPONIBILE - SECTIONAL SOFA

00198/I - l. 453 x p. 101 x h. 66 cm

Divano componibile con struttura in multistrati, rivestimento con gomme di varie densità, strato superiore in air soft ricoperto da una soffice falda di piuma d'oca su tutta la superficie. Strato superiore di cuscini e seduta con gomma Memory di 3 cm. Seduta con cinghie elastiche da 6 cm.

Modular sofa with plywood structure, covered with multi-density rubbers, upper layer in air soft, covered with a soft layer of goose down over the entire surface. Top layer of cushions and seat in 3 cm Memory rubber. Seat with 6 cm elastic belts.

PAG.
Vol.1 - 130, 131, 134, 135, 136, 137, 138, 139, 140, 141, 144, 145, 146, 147, 148, 149, 150, 151

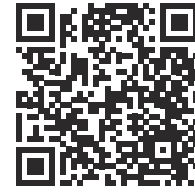
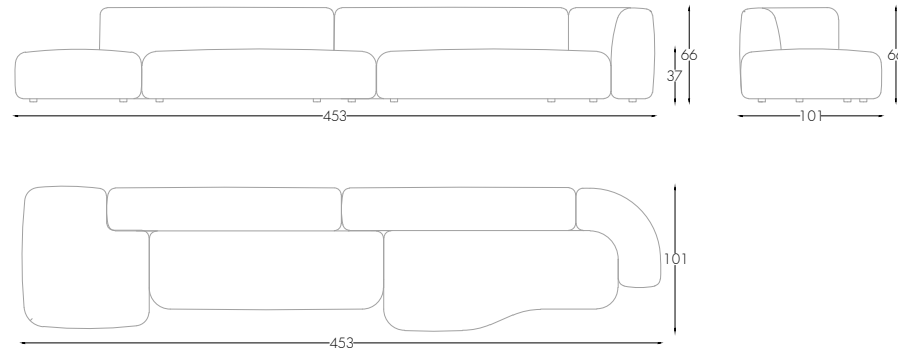

Santa Cruz

DIVANO COMPONIBILE - SECTIONAL SOFA

00198/L - l. 437 x p. 121 x h. 67 cm

Divano componibile con struttura in multistrati, rivestimento con gomme di varie densità, strato superiore in air soft ricoperto da una soffice falda di piuma d'oca su tutta la superficie. Strato superiore di cuscini e seduta con gomma Memory di 3 cm. Seduta con cinghie elastiche da 6 cm.

Modular sofa with plywood structure, covered with multi-density rubbers, upper layer in air soft, covered with a soft layer of goose down over the entire surface. Top layer of cushions and seat in 3 cm Memory rubber. Seat with 6 cm elastic belts.

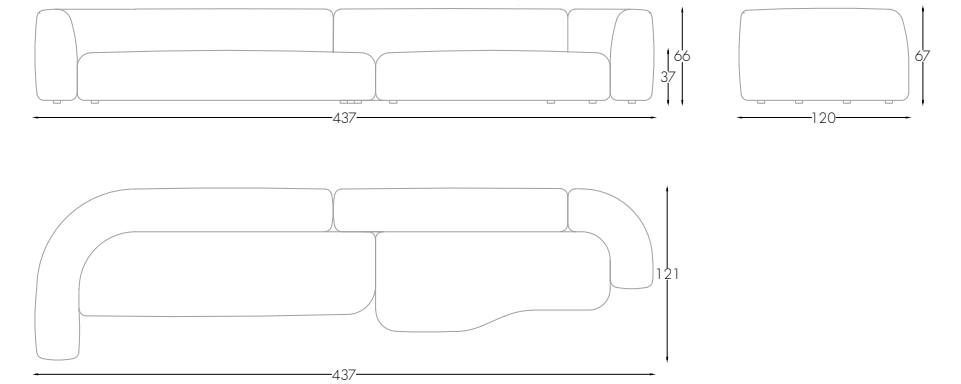

Santa Cruz

DIVANO COMPONIBILE - SECTIONAL SOFA

00198/H - l. 299 x p. 101 x h. 66 cm

Divano componibile con struttura in multistrati, rivestimento con gomme di varie densità, strato superiore in air soft ricoperto da una soffice falda di piuma d'oca su tutta la superficie. Strato superiore di cuscini e seduta con gomma Memory di 3 cm. Seduta con cinghie elastiche da 6 cm.

Modular sofa with plywood structure, covered with multi-density rubbers, upper layer in air soft, covered with a soft layer of goose down over the entire surface. Top layer of cushions and seat in 3 cm Memory rubber. Seat with 6 cm elastic belts.

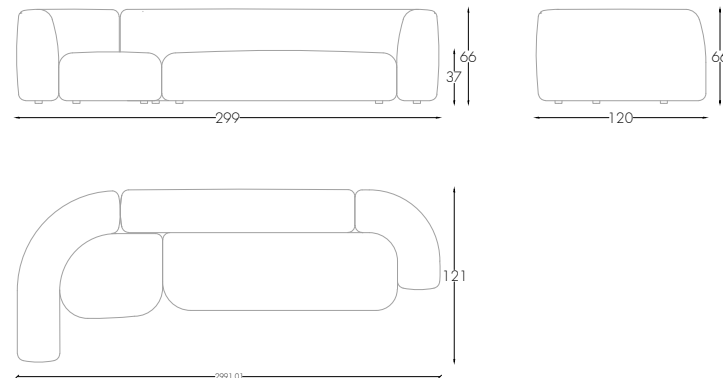

Santa Cruz

DIVANO COMPONIBILE - SECTIONAL SOFA

00198/O - l. 287 x p. 300 x h. 66 cm

Divano componibile con struttura in multistrati, rivestimento con gomme di varie densità, strato superiore in air soft ricoperto da una soffice falda di piuma d'oca su tutta la superficie. Strato superiore di cuscini e seduta con gomma Memory di 3 cm. Seduta con cinghie elastiche da 6 cm.

Modular sofa with plywood structure, covered with multi-density rubbers, upper layer in air soft, covered with a soft layer of goose down over the entire surface. Top layer of cushions and seat in 3 cm Memory rubber. Seat with 6 cm elastic belts.

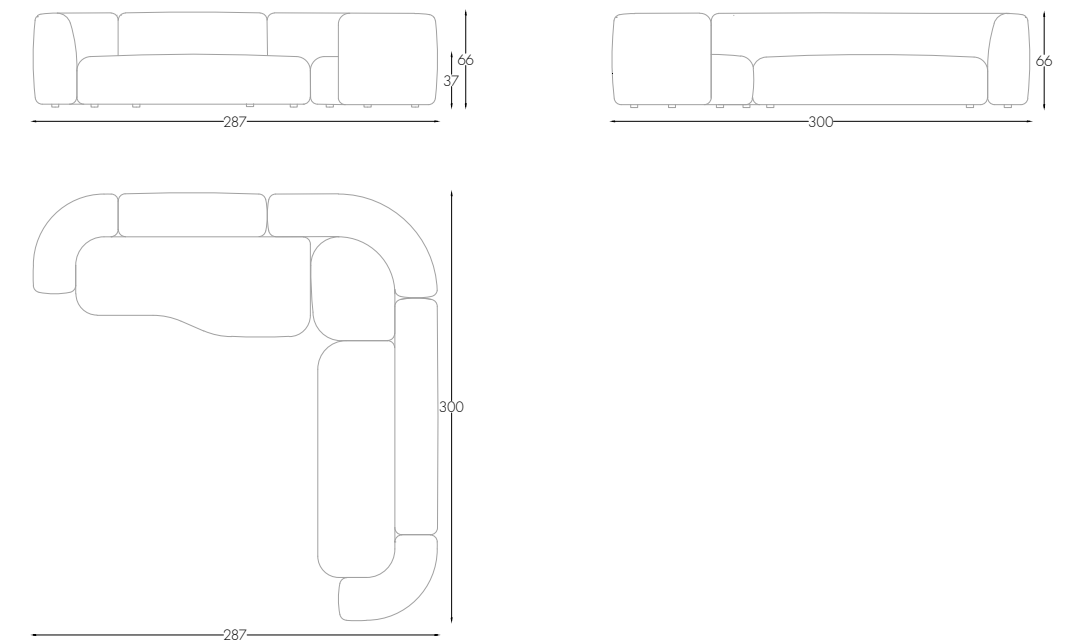

Santa Cruz

DIVANO COMPONIBILE - SECTIONAL SOFA

Angular - 00198/P - l. 436 x p. 356 x h. 66 cm

Divano componibile con struttura in multistrati, rivestimento con gomme di varie densità, strato superiore in air soft ricoperto da una soffice falda di piuma d'oca su tutta la superficie. Strato superiore di cuscini e seduta con gomma Memory di 3 cm. Seduta con cinghie elastiche da 6 cm.

Modular sofa with plywood structure, covered with multi-density rubbers, upper layer in air soft, covered with a soft layer of goose down over the entire surface. Top layer of cushions and seat in 3 cm Memory rubber. Seat with 6 cm elastic belts.

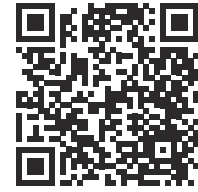
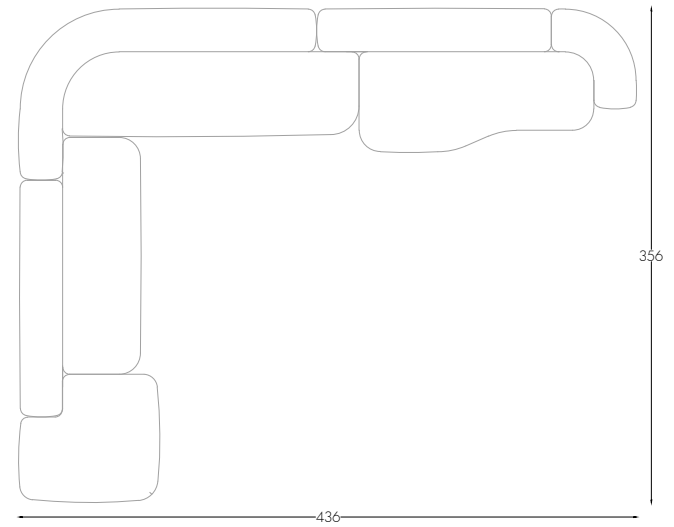
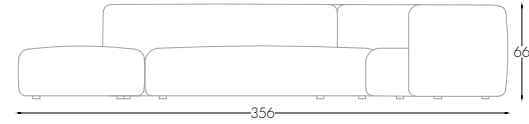
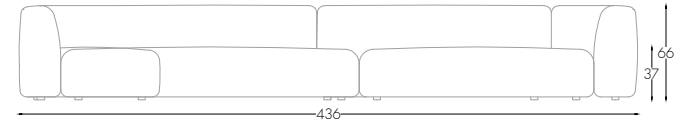

Santa Cruz

DIVANO COMPONIBILE - SECTIONAL SOFA

Angular - 00198/Q - l. 497 x p. 466 x h. 66 cm

Divano componibile con struttura in multistrati, rivestimento con gomme di varie densità, strato superiore in air soft ricoperto da una soffice falda di piuma d'oca su tutta la superficie. Strato superiore di cuscini e seduta con gomma Memory di 3 cm. Seduta con cinghie elastiche da 6 cm.

Modular sofa with plywood structure, covered with multi-density rubbers, upper layer in air soft, covered with a soft layer of goose down over the entire surface. Top layer of cushions and seat in 3 cm Memory rubber. Seat with 6 cm elastic belts.

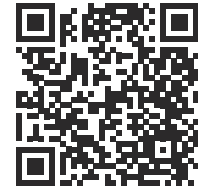
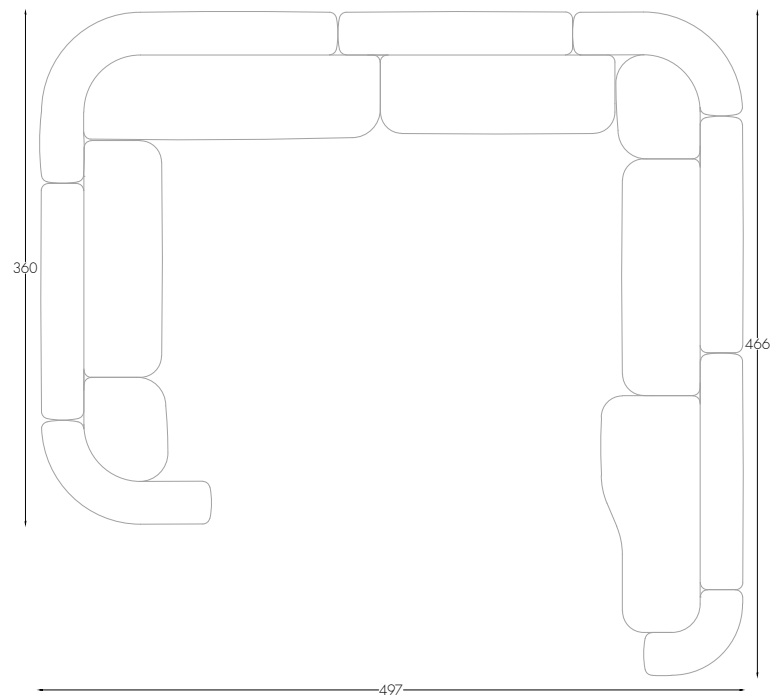
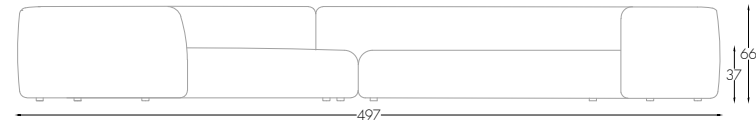

Leo

DIVANO COMPONIBILE - SECTIONAL SOFA

00309 - l. 180 x p. 95 x h. 78 cm
 00310 - l. 250 x p. 95 x h. 78 cm
 00158 - l. 270 x p. 95 x h. 78 cm
 00311 - l. 320 x p. 95 x h. 78 cm

Divano componibile con struttura in multistrati, rivestimento con gomme di varie densità, strato superiore in air soft ricoperto da una soffice falda di piuma d'oca su tutta la superficie. Strato superiore di cuscini e seduta con gomma Memory di 3 cm. Seduta con cinghie elastiche da 6 cm. Piedi finitura in ottone brunito.

Modular sofa with plywood structure, covered with multi-density rubbers, upper layer in air soft, covered with a soft layer of goose down over the entire surface. Top layer of cushions and seat in 3 cm Memory rubber. Seat with 6 cm elastic belts. Burnished brass feet.

PAG.
 Vol.1 - 162, 163, 164, 166, 167

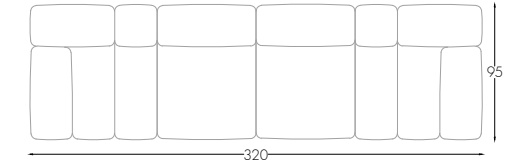
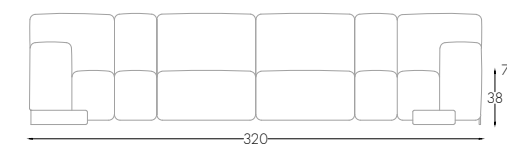
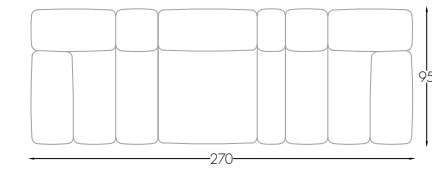
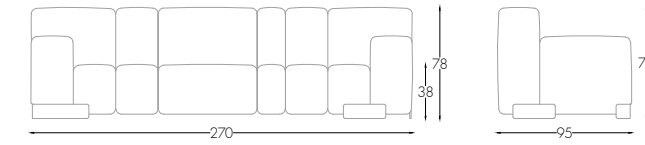
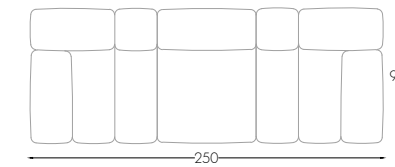
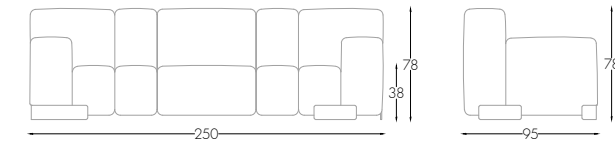
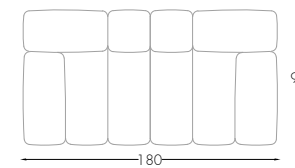
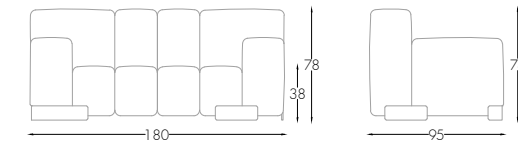

Lifestyle

DIVANO - SOFA

00254 - l. 250 x p. 107 x h. 77 cm
 00254/P - l. 210 x p. 107 x h. 77 cm
 00254/G - l. 290 x p. 107 x h. 77 cm

Struttura in multistrati e acciaio, rivestimento con gomme di varie densità, strato superiore in Memory ricoperto da una soffice falda di piuma d'oca su tutta la superficie. Seduta con cinghie elastiche da 6 cm. Basamento in ottone satinato.

Plywood and steel structure, covered in multi-density rubber, upper layer in Memory foam, all-over surface of soft goose down. Seat with 6 cm elastic belts. Burnished brass base.

PAG.
 Vol.1 - 122, 124, 125, 126, 127, 128, 129

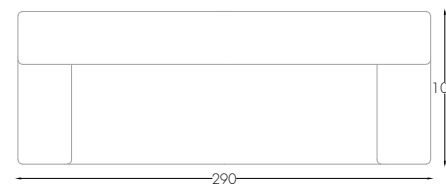
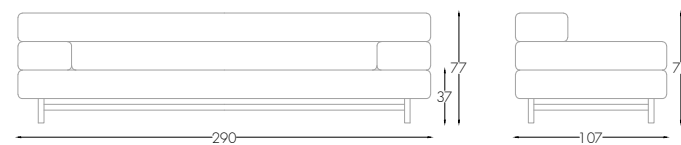
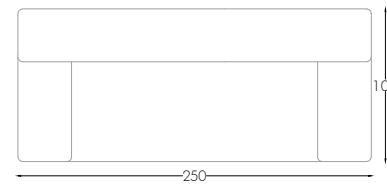
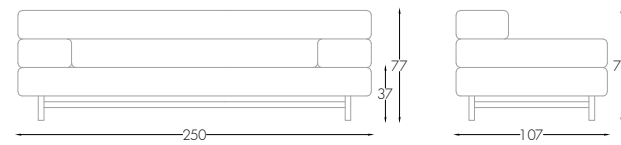
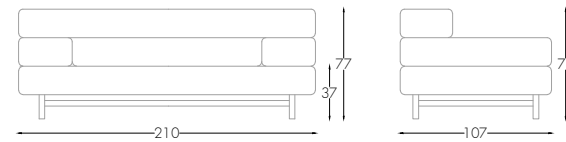

Riverside

DIVANO - SOFA

00244 - l. 260 x p. 96 x h. 78 cm
 00244/P - l. 220 x p. 96 x h. 78 cm
 00244/G - l. 300 x p. 96 x h. 78 cm

Struttura in multistrati, rivestimento con gomme di varie densità, strato superiore in Memory ricoperto da una soffice falda di piuma d'oca su tutta la superficie. Cuscini schienale in piuma d'oca. Seduta con cinghie elastiche da 6 cm. Decorati piedi e distanziali passamano schienale in ottone satinato.

Plywood structure, covered in multi-density rubber, upper layer in Memory foam, all-over surface of soft goose down. Backrest cushions of goose down. Seat with 6 cm elastic belts. Décor of feet and backrest rail spacers in satin brass.

PAG.
 Vol.1 - 62, 63, 64, 65, 66, 68, 69

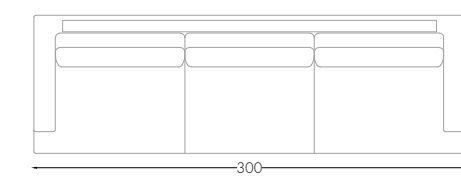
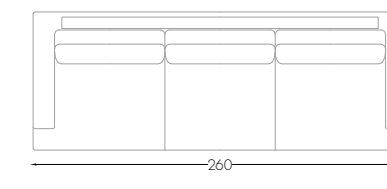
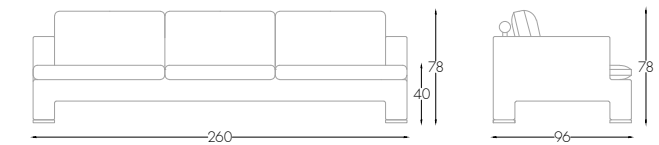
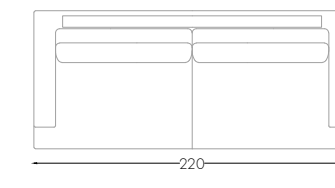
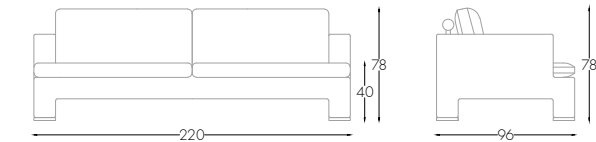

Samarkanda

DIVANO - SOFA

00237 - l. 250 x p. 87 x h. 75 cm
 00237/P - l. 216 x p. 87 x h. 75 cm
 00237/G - l. 284 x p. 87 x h. 75 cm

Struttura in multistrati e acciaio, rivestimento con gomme di varie densità, strato superiore in Memory ricoperto da una soffice falda di piuma d'oca su tutta la superficie. Zip decorativa e piedi in acciaio finitura nero opaco. Seduta con cinghie elastiche da 6 cm.

Plywood and steel structure, covered in multi-density rubber, upper layer in Memory foam, all-over surface of soft goose down. Decorative zip and steel feet with opaque black finish. Seat with 6 cm elastic belts.



PAG.

Vol.1 - 44, 45, 47, 48, 49, 52, 53, 54

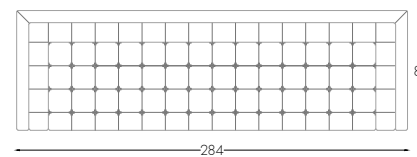
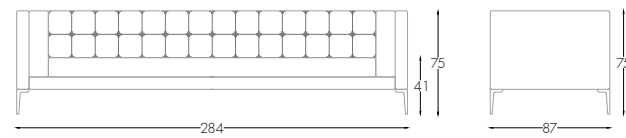
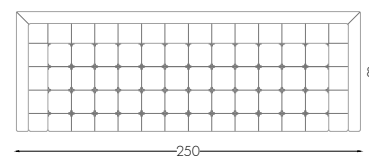
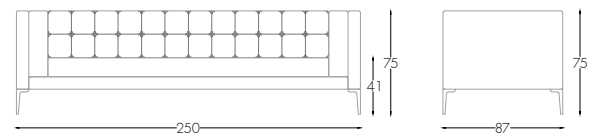
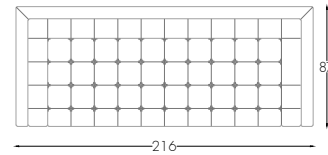
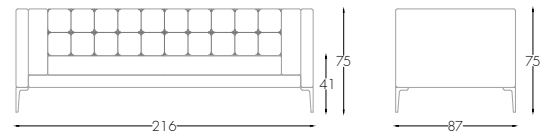

Haring

DIVANO - SOFA

00241 - l. 260 x p. 88 x h. 76 cm
 00241/P - l. 215 x p. 88 x h. 76 cm
 00241/G - l. 300 x p. 88 x h. 76 cm

Struttura in multistrati, rivestimento con gomme di varie densità, strato superiore in Memory ricoperto da una soffice falda di piuma d'oca su tutta la superficie. Cuscini schienale in piuma d'oca. Seduta con cinghie elastiche da 6 cm. Basamento in multistrati foderato da lamina in ottone satinato.

Plywood structure, covered in multi-density rubber, upper layer in Memory foam, all-over surface of soft goose down. Backrest cushions of goose down. Seat with 6 cm elastic belts. Plywood base with satin brass laminate.



PAG.

Vol.1 - 34, 36, 37, 38, 39, 40, 41

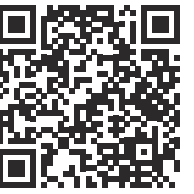
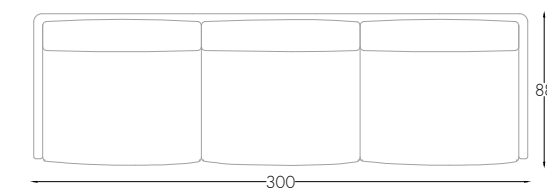
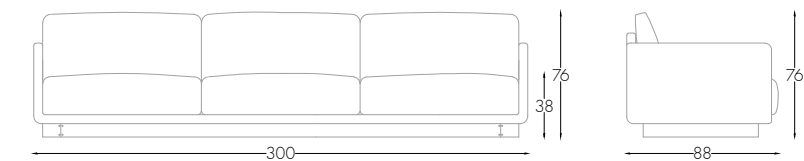
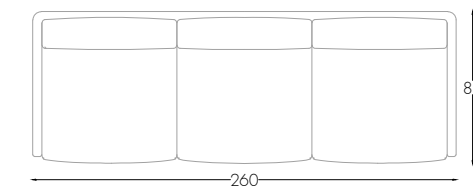
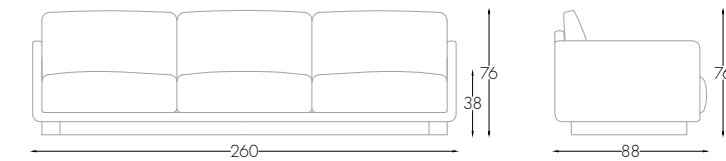
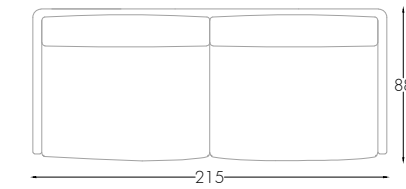
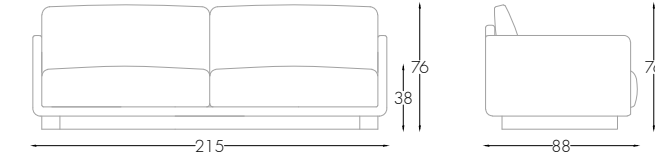

Ermes

DIVANO - SOFA

00093 - l. 290 x p. 90 x h. 85 cm
00093/M - l. 250 x p. 90 x h. 85 cm
00093/P - l. 200 x p. 90 x h. 85 cm

Struttura in multistrati, rivestimento con gomme di varie densità, strato superiore in air soft, ricoperto da una soffice falda di piuma d'oca su tutta la superficie. Lavorazione capitonné. Strato superiore dei cuscini di seduta con gomma Memory da 3 cm. Seduta con cinghie elastiche da 6 cm.

Plywood structure, covered with multi-density rubbers, upper layer in air soft, covered with a soft layer of goose down over the entire surface. Quilted with capitonné motive. Top layer of cushions and seat in 3 cm Memory rubber. Seat with 6 cm elastic belts.

PAG.
Vol.1 - 270, 271, 272

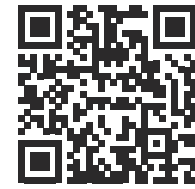
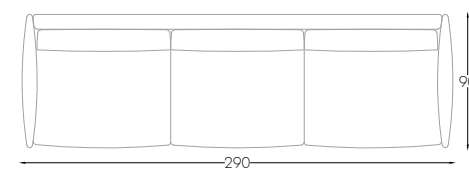
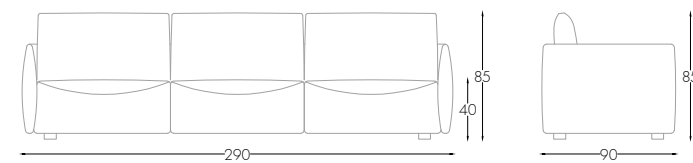
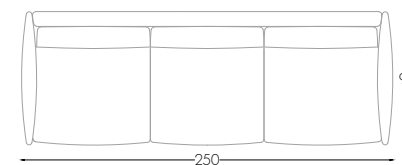
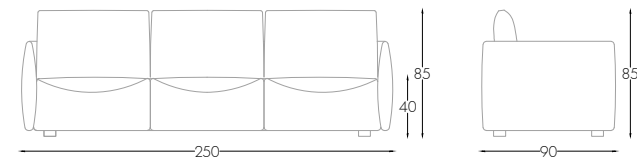
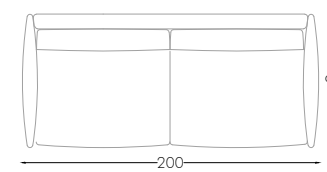
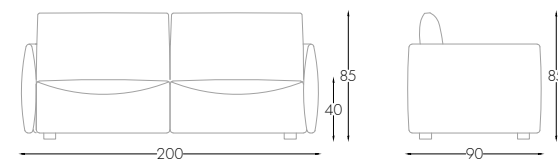

Brera

DIVANO - SOFA

00094/P - l. 204 x p. 91 x h. 82 cm
00094/M - l. 250 x p. 91 x h. 82 cm
00094 - l. 294 x p. 91 x h. 82 cm

Struttura in multistrati, rivestimento con gomme di varie densità, strato superiore in air soft, ricoperto da una soffice falda di piuma d'oca su tutta la superficie. Strato superiore dei cuscini di seduta con gomma Memory da 3 cm. Seduta con cinghie elastiche da 6 cm. Rivestimento su scocca con trapuntatura a rombi.

Plywood structure, covered with multi-density rubbers, upper layer in air soft, covered with a soft layer of goose down over the entire surface. Top layer of cushions and seat in 3 cm Memory rubber. Seat with 6 cm elastic belts. Diamond-quilted upholstery on the external structure.

PAG.
Vol.1 - 254, 255, 257

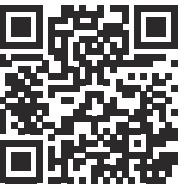
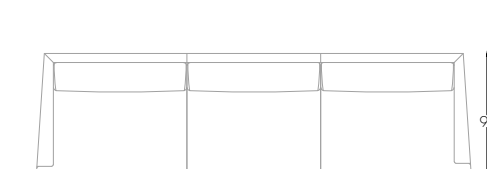
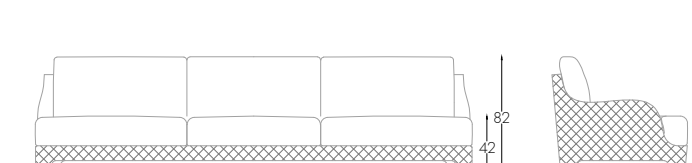
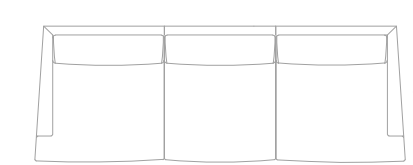
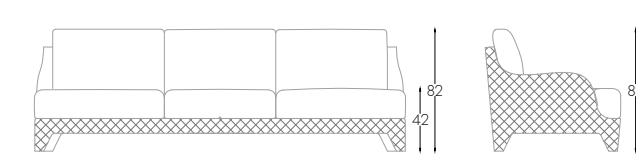
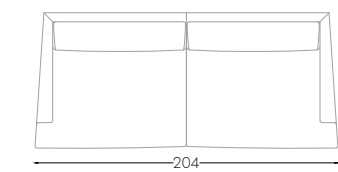
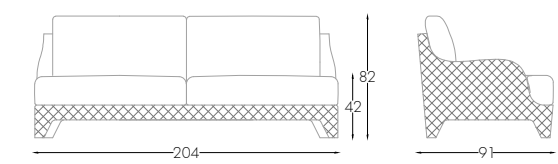

Mark

DIVANO - SOFA

00026 - l. 270 x p. 100 x h. 85 cm
00026/P - l. 220 x p. 100 x h. 85 cm

Struttura in multistrati, rivestimento con gomme di varie densità, strato superiore in air soft, ricoperto da una soffice falda di piuma d'oca su tutta la superficie. Strato superiore dei cuscini di seduta con gomma Memory da 3 cm. Seduta con cinghie elastiche da 6 cm. Rivestimento dello schienale con trapuntatura a rombi.

Plywood structure, covered with multi-density rubbers, upper layer in air soft, covered with a soft layer of goose down over the entire surface. Top layer of cushions and seat in 3 cm Memory rubber. Seat with 6 cm elastic belts. Diamond-quilted upholstery on the structure.

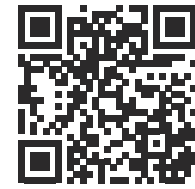
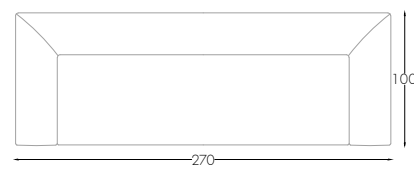
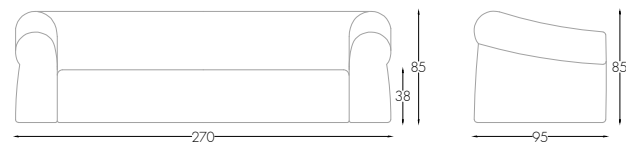
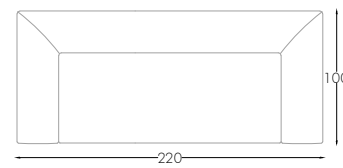
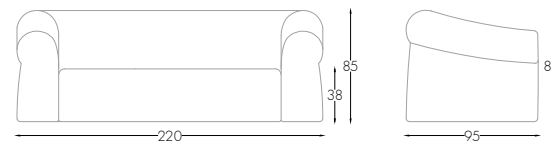

Vogue

DIVANO - SOFA

00157/P - l. 210 x p. 100 x h. 71 cm
00157 - l. 250 x p. 100 x h. 71 cm
00157/G - l. 290 x p. 100 x h. 71 cm

Struttura in multistrati, rivestimento con gomme di varie densità, strato superiore in air soft, ricoperto da una soffice falda di piuma d'oca su tutta la superficie. Lavorazione capitonné. Strato superiore dei cuscini di seduta con gomma Memory da 3 cm. Seduta con cinghie elastiche da 6 cm. Basamento in multistrati con lamina finitura ottone brunito.

Plywood structure, covered with multi-density rubbers, upper layer in air soft, covered with a soft layer of goose down over the entire surface. Quilted with capitonné motive. Top layer of cushions and seat in 3 cm Memory rubber. Seat with 6 cm elastic belts. Plywood base with burnished brass veneer.

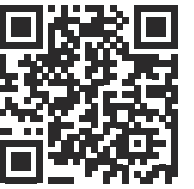
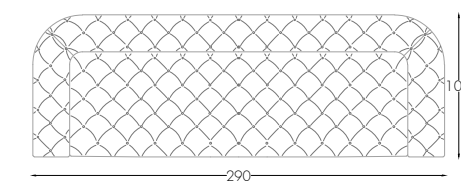
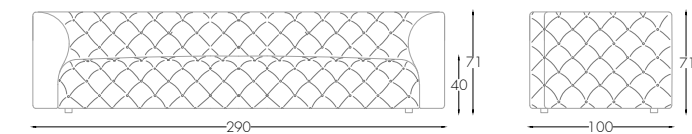
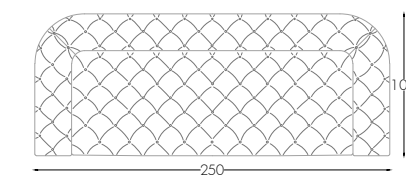
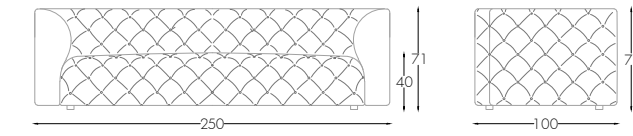
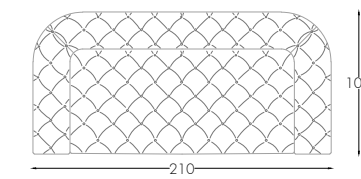
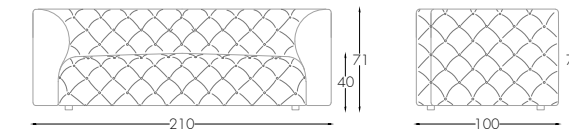

Radetzky

DIVANO - SOFA

00103/P - l. 220 x p. 92 x h. 68 cm
00103 - l. 260 x p. 92 x h. 68 cm
00103/G - l. 290 x p. 92 x h. 68 cm

Struttura in multistrati, rivestimento con gomme di varie densità, strato superiore in air soft, ricoperto da una soffice falda di piuma d'oca su tutta la superficie. Strato superiore dei cuscini di seduta con gomma Memory da 3 cm. Seduta con cinghie elastiche da 6 cm. Scocca esterna in multistrati curvato con foderina di noce dark, finitura lucida spazzolata. Basamento con lamina in ottone brunito.

Plywood structure, covered with multi-density rubbers, upper layer in air soft, covered with a soft layer of goose down over the entire surface. Top layer of cushions and seat in 3 cm Memory rubber. Seat with 6 cm elastic belts. External body in curved plywood with dark walnut veneer and brushed gloss finish. Base covered with burnished brass foil.

PAG.
Vol.1 - 278, 279, 281

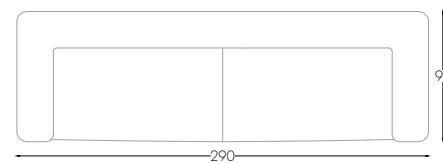
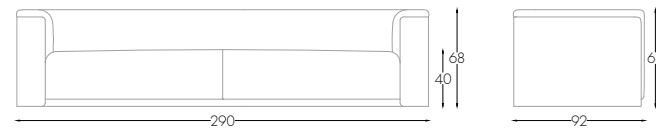
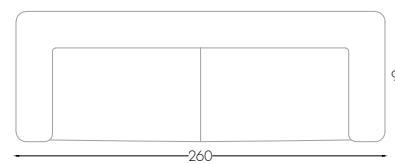
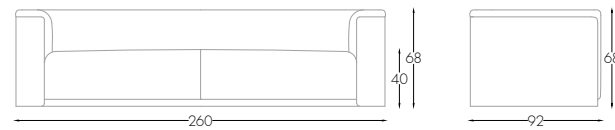
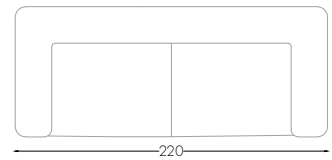
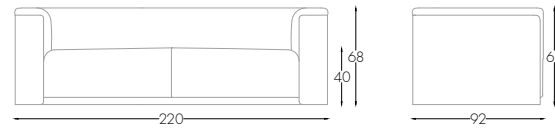

Veyron

DIVANO - SOFA

00049 - l. 206 x p. 100 x h. 85 cm

Struttura in multistrati, rivestimento con gomme di varie densità, strato superiore in air soft, ricoperto da una soffice falda di piuma d'oca su tutta la superficie. Strato superiore dei cuscini di seduta con gomma Memory da 3 cm. Seduta con cinghie elastiche da 6 cm. Piedi in acero massello o noce canaletto.

Plywood structure, covered with multi-density rubbers, upper layer in air soft, covered with a soft layer of goose down over the entire surface. Top layer of cushions and seat in 3 cm Memory rubber. Seat with 6 cm elastic belts. Brushed glossy solid maple or walnut base.

PAG.
Vol.1 - 242, 243, 246

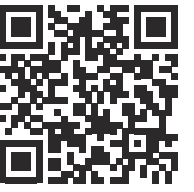
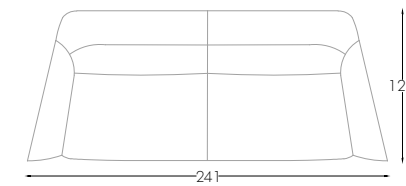
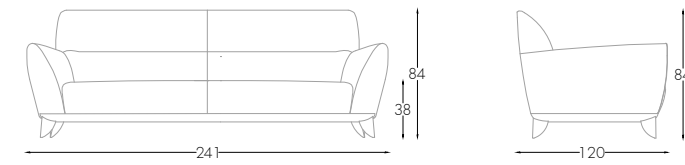

Martin

DIVANO - SOFA

00065 - l. 266 x p. 110 x h. 85 cm
00065/P - l. 224 x p. 110 x h. 85 cm
00065/G - l. 300 x p. 110 x h. 85 cm

Struttura in multistrati, rivestimento con gomme di varie densità, strato superiore in air soft, ricoperto da una soffice falda di piuma d'oca su tutta la superficie. Strato superiore dei cuscini di seduta con gomma Memory da 3 cm. Seduta con cinghie elastiche da 6 cm. Basamento in ottone brunito. Schienale e braccioli con trapuntatura Cannetté.

Plywood structure, covered with multi-density rubbers, upper layer in air soft, covered with a soft layer of goose down over the entire surface. Top layer of cushions and seat in 3 cm Memory rubber. Seat with 6 cm elastic belts. Burnished brass base. Cannetté upholstery on the back and on the armrests.

PAG.
Vol.1 - 260, 261, 262, 263

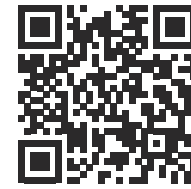
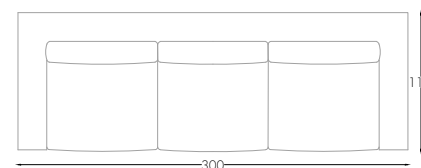
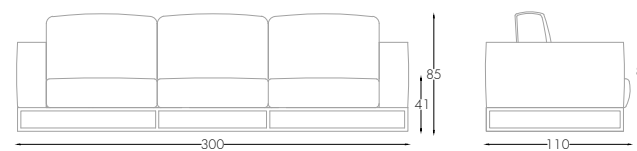
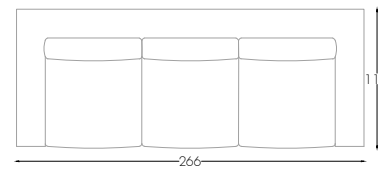
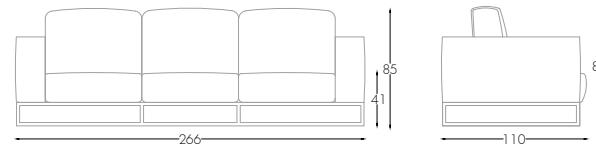
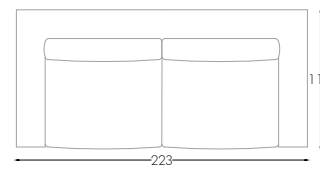
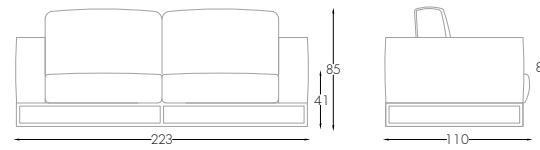

Royale

DIVANO - SOFA

00067 - l. 290 x p. 110 x h. 87 cm

Struttura in multistrati, rivestimento con gomme di varie densità, strato superiore in air soft, ricoperto da una soffice falda di piuma d'oca su tutta la superficie. Strato superiore dei cuscini di seduta con gomma Memory da 3 cm. Seduta con cinghie elastiche da 6 cm. Basamento in multistrati con lamina ottone brunito.

Plywood structure, covered with multi-density rubbers, upper layer in air soft, covered with a soft layer of goose down over the entire surface. Top layer of cushions and seat in 3 cm Memory rubber. Seat with 6 cm elastic belts. Plywood base covered with burnished brass foil.

PAG.
Vol.1 - 248, 249

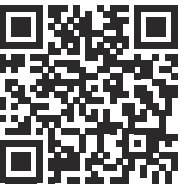
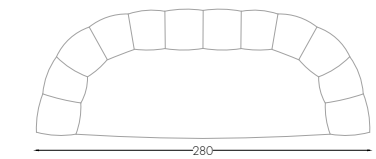
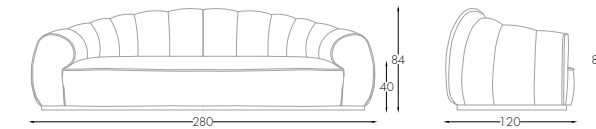

Olimpia

LOVE SEAT

00187 - l. 200 x p. 80 x h. 76 cm

Struttura in multistrati, rivestimento con gomme di varie densità, strato superiore in air soft ricoperto da una soffice falda di piuma d'oca su tutta la superficie. Strato superiore di cuscini e seduta con gomma Memory di 3 cm. Seduta con cinghie elastiche da 6 cm. Piedi in ottone brunito. Trapuntatura a rombi su scocca.

Modular sofa with plywood structure, covered with multi-density rubbers, upper layer in air soft, covered with a soft layer of goose down over the entire surface. Top layer of cushions and seat in 3 cm Memory rubber. Seat with 6 cm elastic belts. Burnished brass feet. Diamond-quilted upholstery on the external structure.

PAG.
Vol.1 - 188, 189, 190, 191, 214

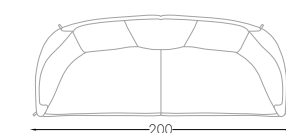
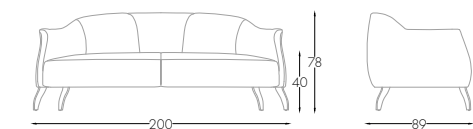

Basic

CUSCINO - CUSHION

00120 - l. 40 x h. 40 cm
00120 - l. 50 x h. 50 cm
00120 - l. 60 x h. 60 cm

Cuscino sfoderabile con zip, interno in piuma d'oca, frammenti di gomma Memory e parte posteriore traforata per un comfort eccellente.

Cushion with zipped removable cover, goose down stuffing, fragments of Memory rubber and openwork back for optimum comfort.

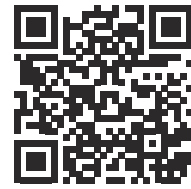

Brand

CUSCINO - CUSHION

00118 - l. 40 x h. 40 cm
00118 - l. 50 x h. 50 cm
00118 - l. 60 x h. 60 cm

Cuscino sfoderabile con zip, interno in piuma d'oca, frammenti di gomma Memory e parte posteriore traforata per un comfort eccellente. Logo ricamato nella parte frontale.

Cushion with zipped removable cover, goose down stuffing, fragments of Memory rubber and openwork back for optimum comfort. Embroidered logo on the frontal part.

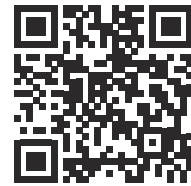

Olimpia

POLTRONA - ARMCHAIR

00184 - l. 82 x p. 84 x h. 79 cm

Struttura in multistrati, rivestimento con gomme di varie densità, strato superiore in air soft ricoperto da una soffice falda di piuma d'oca su tutta la superficie. Strato superiore di cuscini e seduta con gomma Memory di 3 cm. Seduta con cinghie elastiche da 6 cm. Piedi in ottone brunito. Trapuntatura a rombi su scocca.

Plywood structure, covered in multi-density rubber, air soft upper layer, all-over surface layer of soft goose down. Top layer of the seat and the cushions in 3 cm Memory rubber. Seat with 6 cm elastic belts. Burnished brass feet. Diamond-quilted upholstery on the external structure.



PAG.
Vol.1 - 192, 193, 194, 195

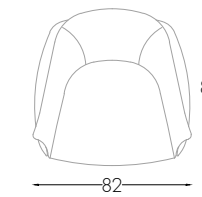
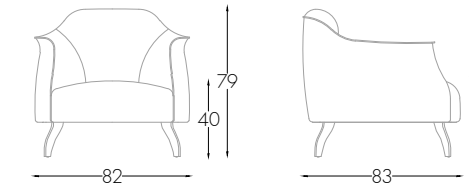

Samarkanda

POLTRONA - ARMCHAIR

00266 - l. 107 x p. 87 x h. 75 cm

Struttura in multistrati, rivestimento con gomme di varie densità, strato superiore in Memory ricoperto da una soffice falda di piuma d'oca su tutta la superficie. Zip decorativa e piedi in acciaio finitura nero opaco. Seduta con cinghie elastiche da 6 cm

Plywood structure, covered in multi-density rubber, upper layer in Memory foam, all-over surface of soft goose down. Decorative zip and steel feet with opaque black finish. Seat with 6 cm elastic belts.



PAG.
Vol.1 - 50, 51

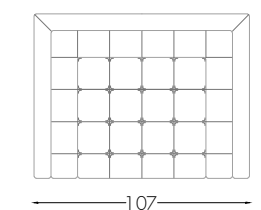
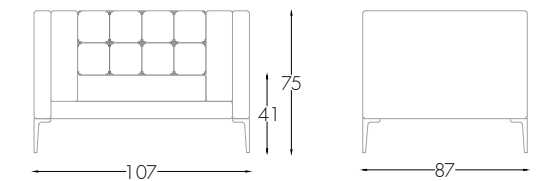

Reed

POLTRONA - ARMCHAIR

00249 - l. 80 x p. 89 x h. 76 cm

Struttura in multistrati, rivestimento con gomme di varie densità, strato superiore in Memory, ricoperto da una soffice falda di piuma d'oca su tutta la superficie. Basamento in ottone satinato. Seduta con cinghie elastiche da 6 cm.

Plywood structure, covered in multi-density rubber, upper layer in Memory foam, all-over surface of soft goose down. Satined base. Seat with 6 cm elastic belts.

PAG.
Vol.1 - 116, 117, 118, 119, 120

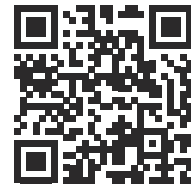
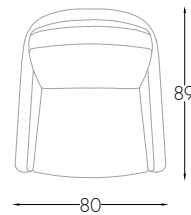
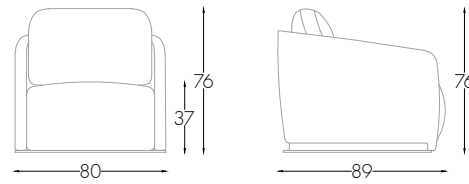

Haring

POLTRONA - ARMCHAIR

00242 - l. 80 x p. 88 x h. 86 cm

Struttura in multistrati, rivestimento con gomme di varie densità, strato superiore in Memory ricoperto da una soffice falda di piuma d'oca su tutta la superficie. Cuscino schienale in piuma d'oca. Seduta con cinghie elastiche da 6 cm. Basamento in multistrati foderato da lamina in ottone satinato.

Plywood structure, covered in multi-density rubber, upper layer in Memory foam, all-over surface of soft goose down. Backrest cushion of goose down. Seat with 6 cm elastic belts. Plywood base with satin brass laminate.

PAG.
Vol.1 - 26, 27, 32, 33, 35

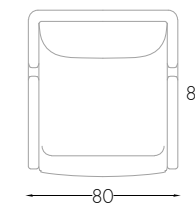
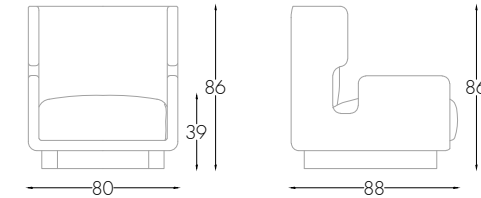

Palmera

POLTRONA - ARMCHAIR

00224 - l. 93 x p. 80 x h. 92 cm

Struttura in multistrati, rivestimento con gomme di varie densità, strato superiore in Memory, ricoperto da una soffice falda di piuma d'oca su tutta la superficie. Seduta con cinghie elastiche da 6 cm. Base multistrati verniciata nero opaco.

Plywood structure, covered in multi-density rubber, upper layer in Memory foam, all-over surface of soft goose down. Burnished brass base. Seat with 6 cm elastic belts. Plywood base with black matt finish.

PAG.
Vol.1 - 77, 82, 83
Vol.2 - 25, 36, 38

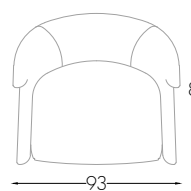
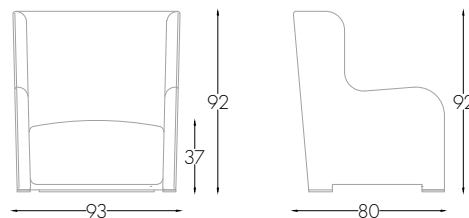

Giza

POLTRONA - ARMCHAIR

00205 - l. 72 x p. 85 x h. 66 cm

Struttura in ottone finitura ottone brunito o titanio, parte inferiore della seduta e schienale in lamina di acciaio rivestita in cuoio, cuscino e seduta in gomma con strato superiore Memory di cm 3.

Burnished brass structure, lower part and back in steel foil covered in leather, cushion and seat in 3 cm Memory rubber.

PAG.
Vol.1 - 76, 77, 108, 109, 110, 111, 144, 154, 300

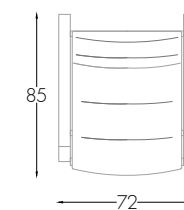
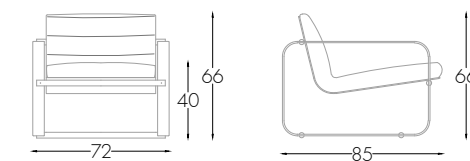

Leo

POLTRONA - ARMCHAIR

00159 - l. 120 x p. 95 x h. 78 cm

Struttura in multistrati, rivestimento con gomme di varie densità, strato superiore in air soft ricoperto da una soffice falda di piuma d'oca su tutta la superficie. Strato superiore di cuscini e seduta con gomma Memory di 3 cm. Seduta con cinghie elastiche da 6 cm. Piedi in ottone brunito.

Plywood structure, covered with multi-density rubbers, upper layer in air soft, covered with a soft layer of goose down over the entire surface. Top layer of cushions and seat in 3 cm Memory rubber. Seat with 6 cm elastic belts. Burnished brass feet.



PAG.
Vol.1 - 169

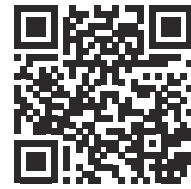
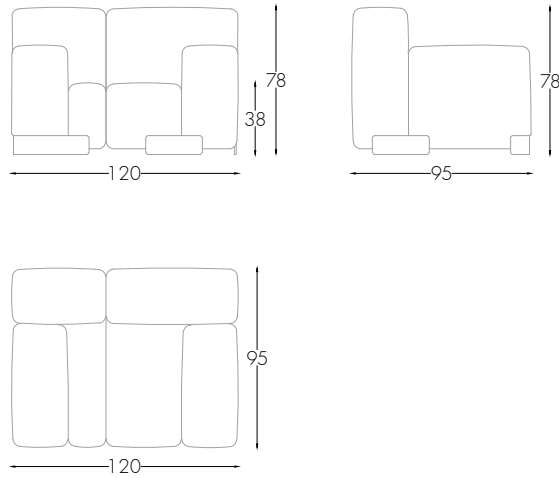

Amy

POLTRONA - ARMCHAIR

00206 - l. 70 x p. 70 x h. 67 cm

Struttura in multistrati, rivestimento con gomme di varie densità, strato superiore in air soft ricoperto da una soffice falda di piuma d'oca su tutta la superficie. Strato superiore di cuscini e seduta con gomma Memory di 3 cm. Seduta con cinghie elastiche da 6 cm. Struttura con trapuntatura a rombi a due aghi, base ottone brunito.

Plywood structure, covered with multi-density rubbers, upper layer in air soft, covered with a soft layer of goose down over the entire surface. Top layer of cushions and seat in 3 cm Memory rubber. Seat with 6 cm elastic belts. Diamond-quilted upholstery with double needle sawing on the structure, burnished brass base.



PAG.
Vol.1 - 62, 63, 68, 69, 70, 71, 72
Vol.2 - 41, 47, 197

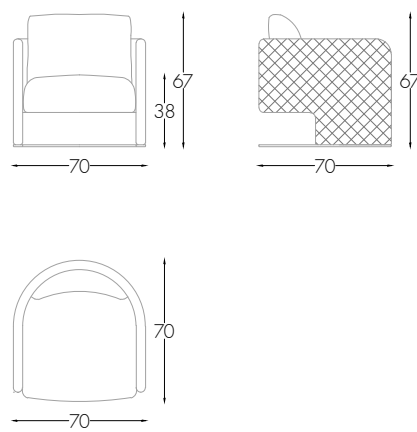

Sue

POLTRONA - ARMCHAIR

00076 - l. 90 x p. 83 x h. 86 cm

Struttura in multistrati, rivestimento con gomme di varie densità, strato superiore in air soft ricoperto da una soffice falda di piuma d'oca su tutta la superficie. Strato superiore di cuscini e seduta con gomma Memory di 3 cm. Seduta con cinghie elastiche da 6 cm. Piedi in acero massello lucido spazzolato.

Plywood structure, covered with multi-density rubbers, upper layer in air soft, covered with a soft layer of goose down over the entire surface. Top layer of cushions and seat in 3 cm Memory rubber. Seat with 6 cm elastic belts. Brushed glossy solid maple base.



PAG.
Vol.1 - 268, 269, 355

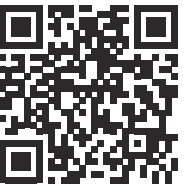
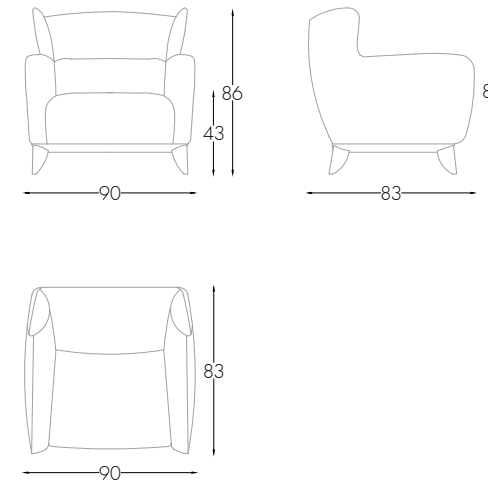

Lolita

POLTRONA - ARMCHAIR

00104 - l. 78 x p. 75 x h. 108 cm

Struttura in multistrati, rivestimento con gomme di varie densità, strato superiore in air soft ricoperto da una soffice falda di piuma d'oca su tutta la superficie. Strato superiore di cuscini e seduta con gomma Memory di 3 cm. Seduta con cinghie elastiche da 6 cm. Schienale in materiale strutturale ma flessibile che rende unica questa tipologia di schienale.

Plywood structure, covered with multi-density rubbers, upper layer in air soft, covered with a soft layer of goose down over the entire surface. Top layer of cushions and seat in 3 cm Memory rubber. Seat with 6 cm elastic belts. Backrest in structured but flexible material, making it one of a kind.



PAG.
Vol.1 - 203

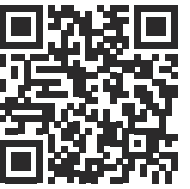
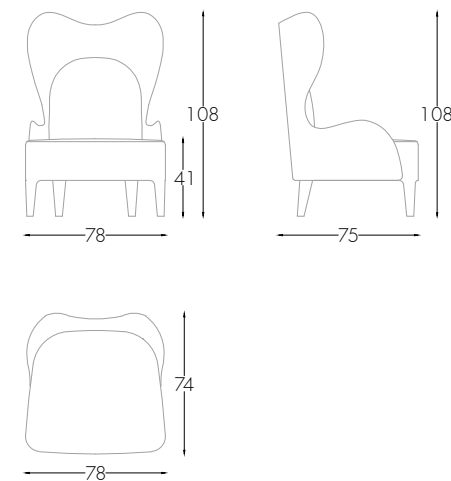

Valentina

POLTRONA - ARMCHAIR

00161 - l. 70 x p. 70 x h. 82 cm

Struttura in multistrati, rivestimento con gomme di varie densità, strato superiore in air soft ricoperto da una soffice falda di piuma d'oca su tutta la superficie. Strato superiore di cuscini e seduta con gomma Memory di 3 cm. Seduta con cinghie elastiche da 6 cm.

Plywood structure, covered with multi-density rubbers, upper layer in air soft, covered with a soft layer of goose down over the entire surface. Top layer of cushions and seat in 3 cm Memory rubber. Seat with 6 cm elastic belts.

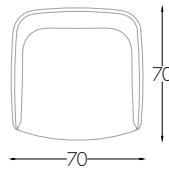
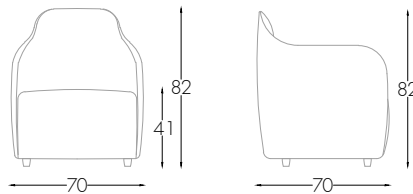

Vol.2 63

Betty

POLTRONA - ARMCHAIR

00036 - l. 78 x p. 74 x h. 70 cm

Struttura in multistrati, rivestimento con gomme di varie densità, strato superiore in air soft ricoperto da una soffice falda di piuma d'oca su tutta la superficie. Strato superiore di cuscini e seduta con gomma Memory di 3 cm. Seduta con cinghie elastiche da 6 cm. Schienale in materiale strutturale ma flessibile che rende unica questa tipologia di componente.

Plywood structure, covered with multi-density rubbers, upper layer in air soft, covered with a soft layer of goose down over the entire surface. Top layer of cushions and seat in 3 cm Memory rubber. Seat with 6 cm elastic belts. Backrest in structured but flexible material, making it one of a kind.

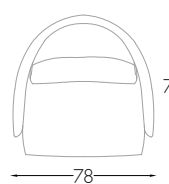
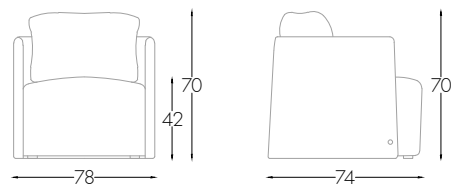

PAG.
Vol.1 - 368



Betty Elite

POLTRONA - ARMCHAIR

00036/J - l. 78 x p. 74 x h. 70 cm

Struttura in multistrati, rivestimento con gomme di varie densità, strato superiore in air soft ricoperto da una soffice falda di piuma d'oca su tutta la superficie. Strato superiore di cuscini e seduta con gomma Memory di 3 cm. Seduta con cinghie elastiche da 6 cm. Schienale in materiale strutturale ma flessibile che rende unica questa tipologia di componente. Schienale stampato jubilee.

Plywood structure, covered with multi-density rubbers, upper layer in air soft, covered with a soft layer of goose down over the entire surface. Top layer of cushions and seat in 3 cm Memory rubber. Seat with 6 cm elastic belts. Backrest in structured but flexible material, making it one of a kind. Back with "jubilee" printing.

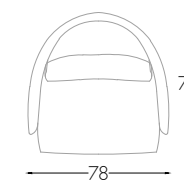
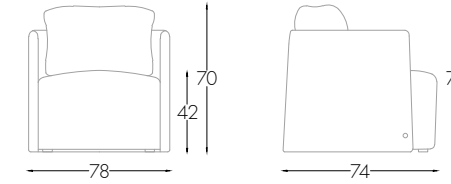

PAG.
Vol.1 - 212, 213



Betty Luxury

POLTRONA - ARMCHAIR

00036/l - l. 78 x p. 74 x h. 70 cm

Struttura in multistrati, rivestimento con gomme di varie densità, strato superiore in air soft ricoperto da una soffice falda di piuma d'oca su tutta la superficie. Strato superiore di cuscini e seduta con gomma Memory di 3 cm. Seduta con cinghie elastiche da 6 cm. Schienale in materiale strutturale ma flessibile che rende unica questa tipologia di componente. Schienale con trapuntatura cannetté.

Plywood structure, covered with multi-density rubbers, upper layer in air soft, covered with a soft layer of goose down over the entire surface. Top layer of cushions and seat in 3 cm Memory rubber. Seat with 6 cm elastic belts. Backrest in structured but flexible material, making it one of a kind. Cannetté upholstery on the back.

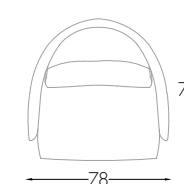
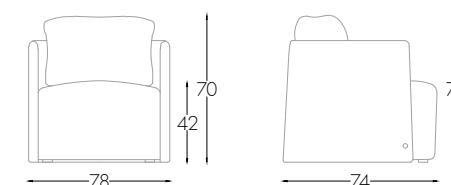

PAG.
Vol.1 - 230



Brera

POLTRONA - ARMCHAIR

00095 - l. 94 x p. 86 x h. 105 cm

Struttura in multistrati, rivestimento con gomme di varie densità, strato superiore in air soft ricoperto da una soffice falda di piuma d'oca su tutta la superficie. Strato superiore di cuscini e seduta con gomma Memory di 3 cm. Seduta con cinghie elastiche da 6 cm. Rivestimento su scocca con trapuntatura a rombi.

Plywood structure, covered with multi-density rubbers, upper layer in air soft, covered with a soft layer of goose down over the entire surface. Top layer of cushions and seat in 3 cm Memory rubber. Seat with 6 cm elastic belts. Diamond-quilted upholstery on the structure.

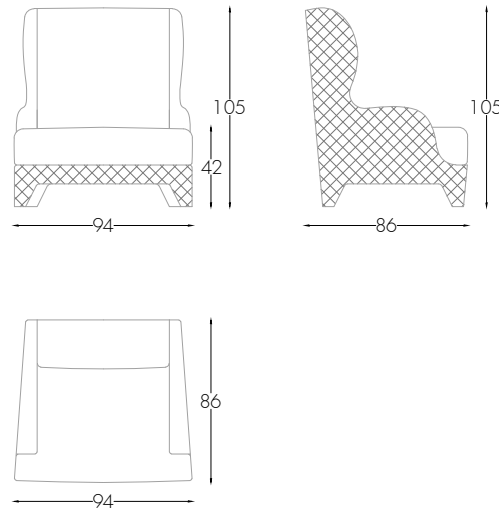

PAG.
Vol.1 - 256

Beatrice

POLTRONCINA - SMALL ARMCHAIR

00089 - l. 70 x p. 65 x h. 68 cm

Struttura in multistrati, rivestimento con gomme di varie densità, strato superiore in air soft ricoperto da una soffice falda di piuma d'oca su tutta la superficie. Strato superiore di cuscini e seduta con gomma Memory di 3 cm. Seduta con cinghie elastiche da 6 cm. Gambe in legno laccato lucido spazzolato.

Plywood structure, covered with multi-density rubbers, upper layer in air soft, covered with a soft layer of goose down over the entire surface. Top layer of cushions and seat in 3 cm Memory rubber. Seat with 6 cm elastic belts. Lacquered glossy brushed wood legs.

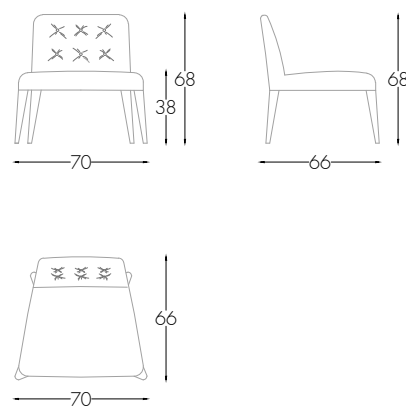

PAG.
Vol.1 - 283

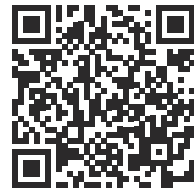

Luna

POLTRONA - ARMCHAIR

00162 - l. 70 x p. 66 x h. 93 cm

Struttura in multistrati, rivestimento con gomme di varie densità, strato superiore in air soft ricoperto da una soffice falda di piuma d'oca su tutta la superficie. Strato superiore di cuscini e seduta con gomma Memory di 3 cm. Seduta con cinghie elastiche da 6 cm. Schienale in materiale strutturale ma flessibile che rende unica questa tipologia di schienale. Basamento girevole. Schienale con trapuntatura cannetté.

Plywood structure, covered with multi-density rubbers, upper layer in air soft, covered with a soft layer of goose down over the entire surface. Top layer of cushions and seat in 3 cm Memory rubber. Seat with 6 cm elastic belts. Backrest in structured but flexible material, making it one of a kind. Swivel base. Cannetté upholstery on the back.

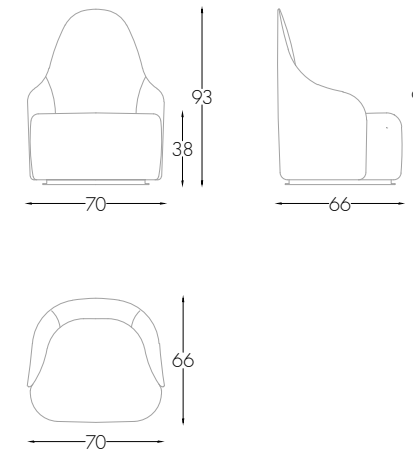

PAG.
Vol.1 - 181, 196
Vol.2 - 124

Palmera

POUFF - POUFFE

0319 - l. 67 x p. 45 x h. 38 cm

Struttura in multistrati, rivestimento con gomme di varie densità, ricoperto da una soffice falda di piuma d'oca su tutta la superficie. Basamento in multistrati verniciato nero opaco.

Plywood structure, covered with multi-density rubbers, upper layer in air soft, covered with a soft layer of goose down over the entire surface. Base in matt black multilayer plywood.

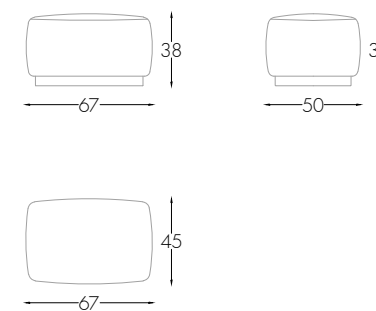

PAG.
Vol.2 - 39

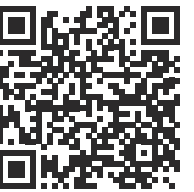
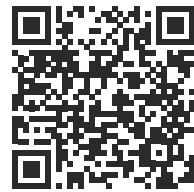

Reed

POUFF - POUFFE

0319 - l. 67 x p. 45 x h. 38 cm
0320 - l. 67 x p. 45 x h. 38 cm

Struttura in multistrati, rivestimento con gomme di varie densità, ricoperto da una soffice falda di piuma d'oca su tutta la superficie. Basamento in ottone satinato.

Plywood structure, covered with multi-density rubbers, upper layer in air soft, covered with a soft layer of goose down over the entire surface. Base in satin brass.

PAG.
Vol.1 - 121

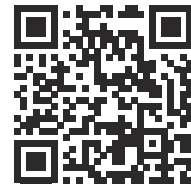
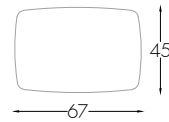
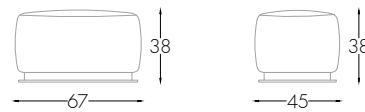

Viper

POUFF - POUFFE

00084 - l. 90 x p. 90 x h. 40 cm

Struttura in multistrati, rivestimento con gomme di varie densità, strato superiore in air soft, ricoperto da una soffice falda di piuma d'oca su tutta la superficie. Trapuntatura cannetté.

Plywood structure, covered with multi-density rubbers, upper layer in air soft, covered with a soft layer of goose down over the entire surface. Cannetté upholstery.

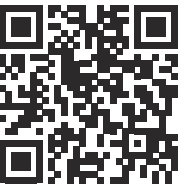
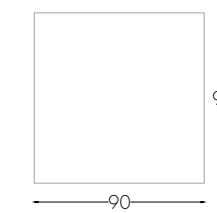
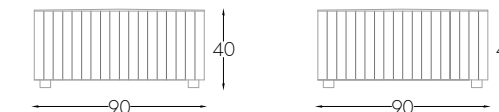

Cobra

POUFF - POUFFE

00078 - Ø 80 x h. 40 cm

Struttura in multistrati, rivestimento con gomme di varie densità, strato superiore in air soft, ricoperto da una soffice falda di piuma d'oca su tutta la superficie. Trapuntatura cannetté.

Plywood structure, covered with multi-density rubbers, upper layer in air soft, covered with a soft layer of goose down over the entire surface. Cannetté upholstery.

PAG.
Vol.2 - 229

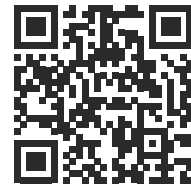
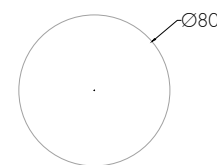
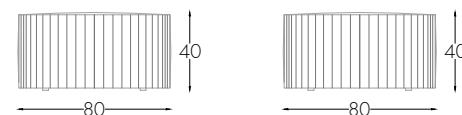

Vogue

POUFF - POUFFE

00156 - l. 140 x p. 140 x h. 40 cm

Struttura in multistrati, rivestimento con gomme di varie densità, strato superiore in air soft, ricoperto da una soffice falda di piuma d'oca su tutta la superficie. Lavorazione capitonné, top vetro nero, basamento in multistrati con lamina in ottone brunito.

Plywood structure, covered with multi-density rubbers, upper layer in air soft, covered with a soft layer of goose down over the entire surface. Quilted with capitonné motive upholstery, black glass top, plywood base covered with burnished brass foil.

PAG.
Vol.1 - 187

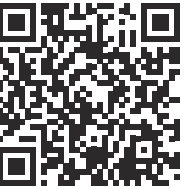
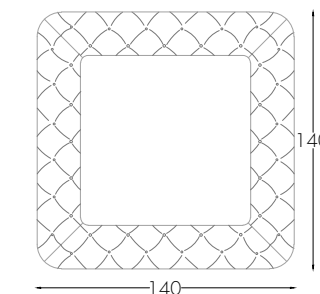
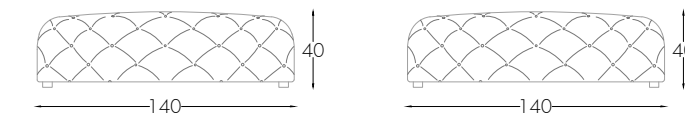

Wimbledon

POUFF - POUFFE

00160 - l. 120 x p. 120 x h. 40 cm

Struttura in multistrati, rivestimento con gomme di varie densità, strato superiore in air soft, ricoperto da una soffice falda di piuma d'oca su tutta la superficie. Trapuntatura a rombi.

Plywood structure, covered with multi-density rubbers, upper layer in air soft, covered with a soft layer of goose down over the entire surface. Diamond-quilted upholstery.

PAG.
Vol.2 - 129, 130, 131

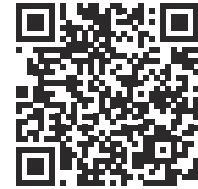
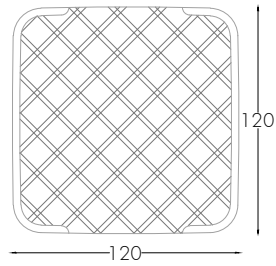
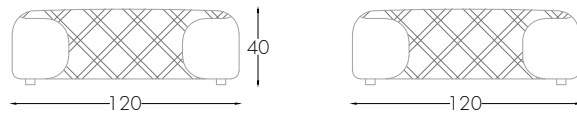

Aimo

TAVOLINO - SIDE TABLE

00225 - l. 107 x p. 102 x h. 36 cm

Struttura in profilato di ottone satinato, blocco basamento in multistrati laccato fumo lucido, top in marmo.

Structure in satin brass profile, plywood base unit with shiny smoke-grey lacquered finish, marble top.

PAG.
Vol.1 - 44, 45, 47, 48, 49, 57

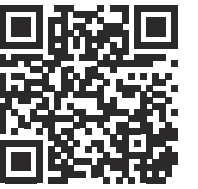
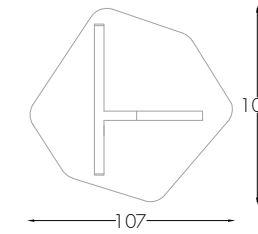
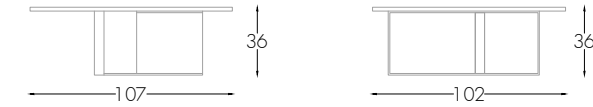

Aimo

TAVOLINO - SIDE TABLE

00269 - l. 49 x p. 44 x h. 52 cm

Struttura in profilato di ottone satinato, blocco basamento in multistrati laccato fumo lucido, top in marmo.

Structure in satin brass profile, plywood base unit with shiny smoke-grey lacquered finish, marble top.

PAG.
Vol.1 - 45, 57

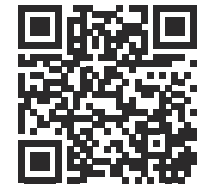
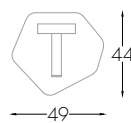
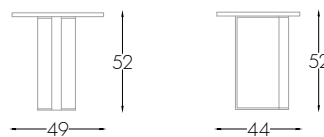

Buddha

TAVOLINO - SIDE TABLE

00201 - l. 58 x p. 56 x h. 51 cm

Struttura in ottone satinato, con dettagli godronati. Top in marmo.

Satin brass structure, with knurled details. Marble top.

PAG.
Vol.1 - 66, 67

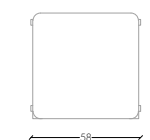
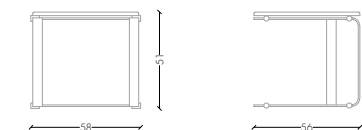

Club

TAVOLINO - SIDE TABLE

00238 - l. 56 x p. 56 x h. 50 cm

Struttura in tubolare di ottone satinato, top in vetro fumé.

Tubular satin brass structure, smoked glass top.

PAG.
Vol.1 - 24, 25, 63

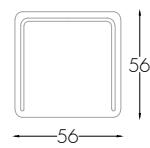
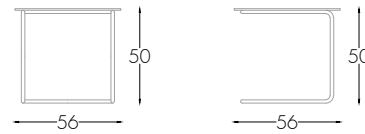

Atollo

COMPOSIZIONE - COMPOSITION

00258 - l. 160 x p. 100 x h. 42 cm

Struttura in multistrati imbottita con gomme di diverse densità. Una sezione (triangolo) con piano rigido ed una sezione con piano morbido. Basamenti in multistrati con lamiera di ottone satinato. Ponte in multistrati laccato fumo lucido con lamina in ottone satinato da 3 mm.

Plywood structure padded with multi-density rubber. A section (triangle) with stiff panel and one with soft panel. Plywood bases with satin brass laminate. Bridge in shiny smoke-lacquered plywood with 3 mm satin brass laminate.

PAG.
Vol.1 - 12, 13, 26, 27, 29

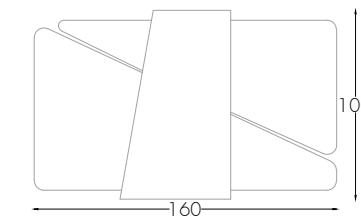
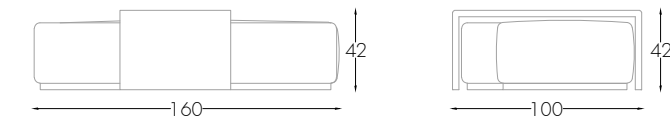

Kevin

TAVOLINO - TABLE

00251 - ø 45 x h. 60 cm
00252 - ø 60 x h. 35 cm

Struttura in multistrati curvato imbottito, base in multistrati con lamina ottone satinato, top a vassoio in ottone satinato e piano vetro laccato nero.

Curved, padded plywood structure, plywood base with satin brass laminate, satin brass tray-top and lacquered black glass counter.

PAG.
Vol.1 - 35, 42, 43

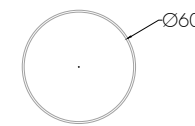
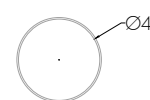
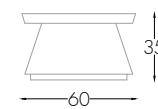
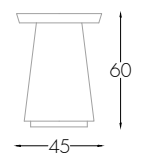

Atollo

POUFF - POUFFE

Stiff panel - 00250 - l. 160 x p. 86 x h. 39 cm
Soft counter - 00290 - l. 145 x p. 69 x h. 39 cm

Struttura in multistrati imbottita con gomme di diverse densità. Piano rigido/morbido. Basamento in multistrati con lamina di ottone satinato.

Plywood structure padded with multi-density rubber. Stiff panel/soft counter. Plywood base with satin brass laminate.

PAG.
Vol.1 - 12, 13, 30, 31

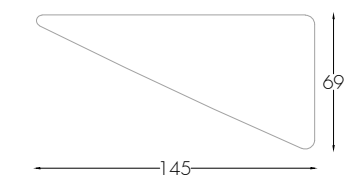
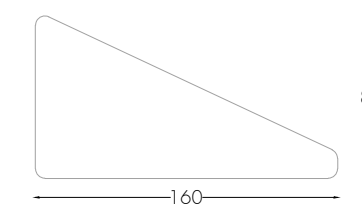
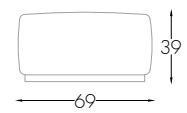
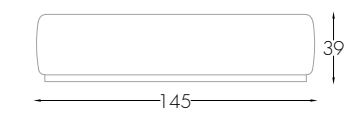
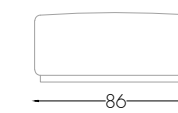
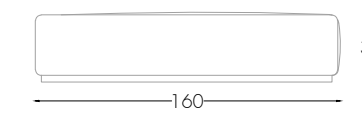

Atollo

TAVOLINO A PONTE - BRIDGE TABLE

00258/T - l. 100 x p. 58 x h. 42 cm

Ponte in multistrati laccato fumo lucido con lamina in ottone satinato da 3 mm.

Bridge in shiny smoke-lacquered plywood with 3 mm satin brass laminate.

PAG.
Vol.1 - 12, 13, 34, 35, 130, 131, 132, 133, 134, 135

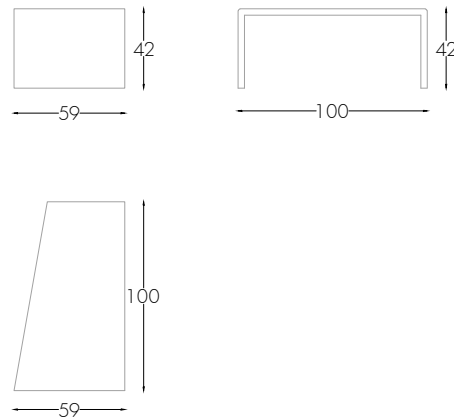

Cotton House

TAVOLINO - SMALL TABLE

00289 - Ø 100 x h. 73 cm

Piano in multistrati con foderina frassino 10/10, gamba in frassino massello. Finitura laccato nero opaco a poro aperto. Basamento in ottone satinato.

Plywood counter lined in 10/10 ashwood veneer, solid ashwood leg. open-pore lacquered opaque black finish. Burnished brass base.

PAG.
Vol.1 - 113, 114

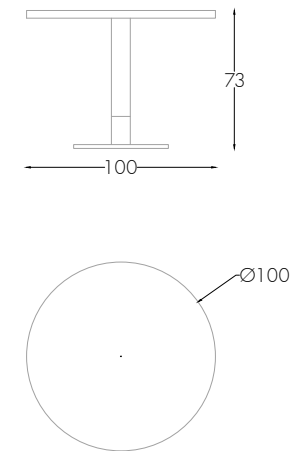

Colette

TAVOLINO - SMALL TABLE

00243 - l. 62 x p. 62 x h. 40 cm

Struttura in tubolare ottone finitura satinata. Top in marmo.

Tubular satin brass structure. Marble top.

PAG.
Vol.1 - 86, 87

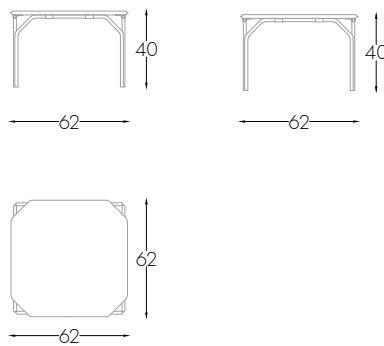

Mayfair

TAVOLINO - COFFEE TABLE

00091 - l. 70 x p. 70 x h. 66 cm

Struttura in multistrati curvato con foderina noce dark, ante con cerniere soft. Top in marmo o pelle. Base con lamina in ottone brunito. Finitura lucida spazzolata.

Curved plywood structure with dark walnut veneer, doors with soft-closing hinges. Marble or leather top. Base covered with burnished brass foil. Brushed glossy finish.

PAG.
Vol.1 - 243

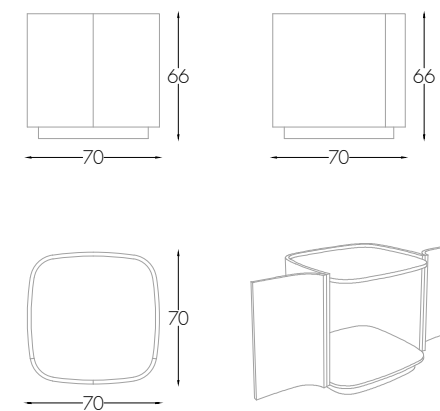

Salina

TAVOLINO - COFFEE TABLE

00203 - l. 45 x p. 45 x h. 33 cm

Struttura in ottone brunito, con inserto godronato e top in vetro laccato.

Structure in burnished brass, with knurled insert and lacquered glass top.

PAG.
Vol.1 - 144, 145, 150, 151, 152, 153, 154, 155, 157

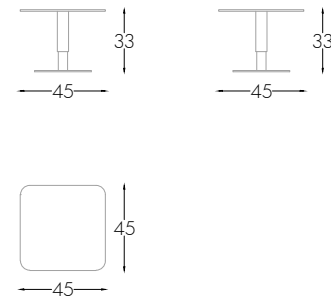

Victoria

TAVOLINO - COFFEE TABLE

00086 - l. 60 x p. 40 x h. 65 cm

Struttura in ottone brunito, top in marmo.

Burnished brass structure, marble top.

PAG.
Vol.1 - 258, 259
Vol.2 - 91

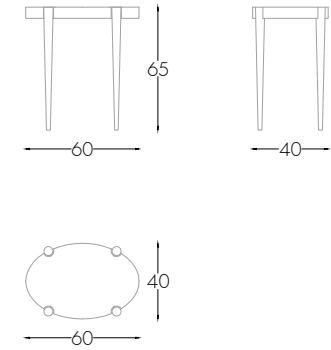

Weybridge

TAVOLINO - COFFEE TABLE

00010 - Ø 65 x h. 65 cm

Struttura in profilato di ottone brunito, top in ottone.

Brass section structure, brass top.
Burnished brass finish.

PAG.
Vol.1 - 246

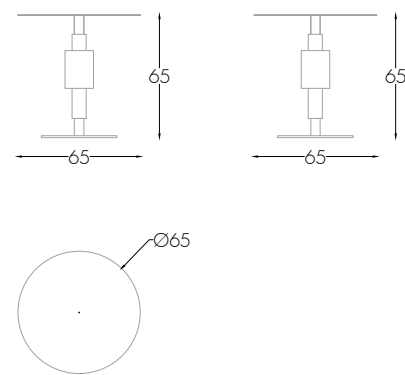

Albert

TAVOLINO - COFFEE TABLE

00090 - l. 70 x p. 70 x h. 45 cm

Struttura in ottone brunito, top in marmo.

Burnished brass structure, marble top.

PAG.
Vol.1 - 235, 238, 239, 266

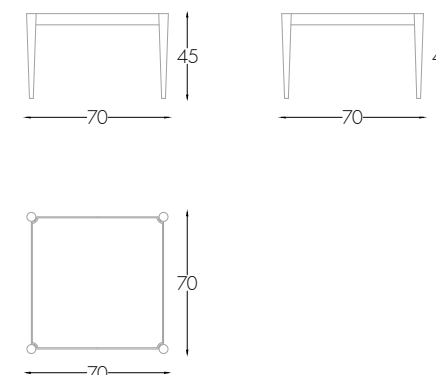

Theo

TAVOLINO - COFFEE TABLE

00068 - l. 75 x p. 60 x h. 35 cm
00068/M - l. 45 x p. 45 x h. 65 cm
00068/P - l. 44 x p. 44 x h. 45 cm

Struttura in ottone brunito.
Top in marmo.

Burnished brass structure.
Marble top.

PAG.
Vol.1 - 220, 244, 279

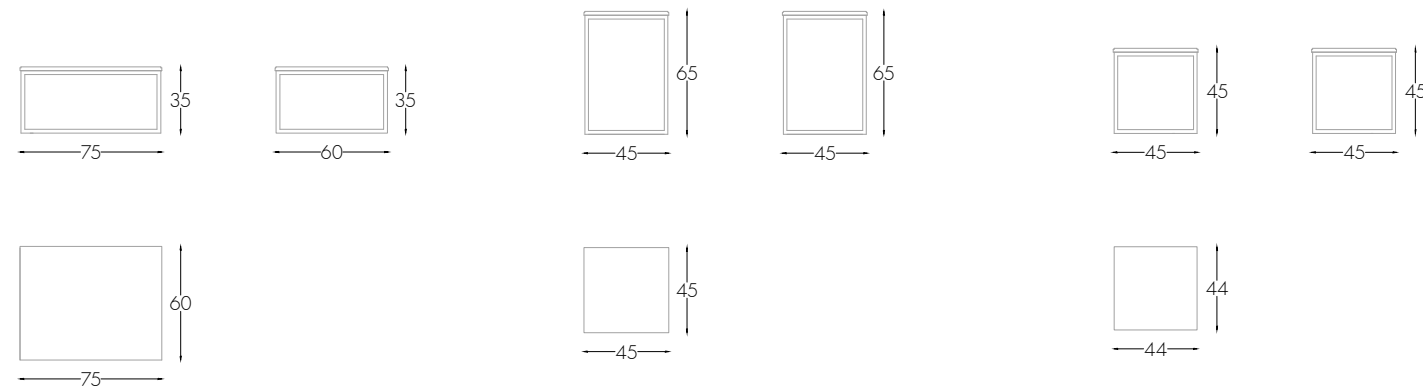

Yoshi

TAVOLINO - COFFEE AND SIDE TABLE

00144 - l. 60 x p. 60 x h. 35 cm
00144/M - l. 45 x p. 45 x h. 45 cm
00144/P - l. 35 x p. 35 x h. 50 cm

Struttura in ottone finitura titanio,
top in marmo.

Burnished brass structure with titanium finish,
marble top.

PAG.
Vol.1 - 169, 188, 189, 200, 201, 214, 215
Vol.2 - 66, 67, 68, 69, 70, 71, 72, 73, 74

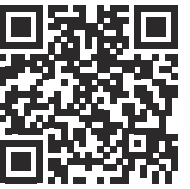
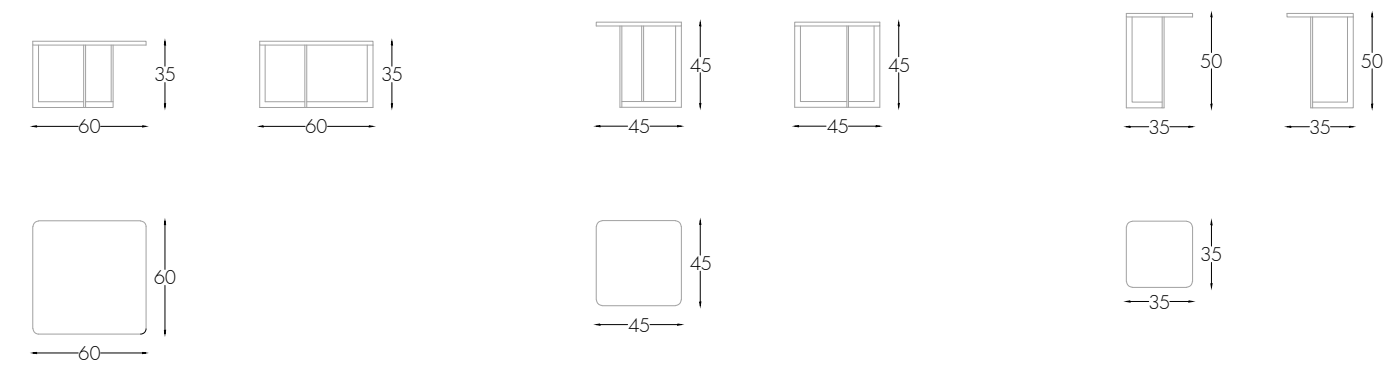

Mondrian

TAVOLINO - SIDE TABLE

00181 - l. 44 x 44 x h. 45 cm
00181/M - l. 39 x 39 x h. 40 cm
00181/P - l. 34 x 34 x h. 35 cm

Struttura in ottone finitura titanio.
Top in vetro fumé.

Burnished brass structure with titanium finish.
Smoked glass.

PAG.
Vol.1 - 171, 176, 177, 182, 183, 184, 185, 187

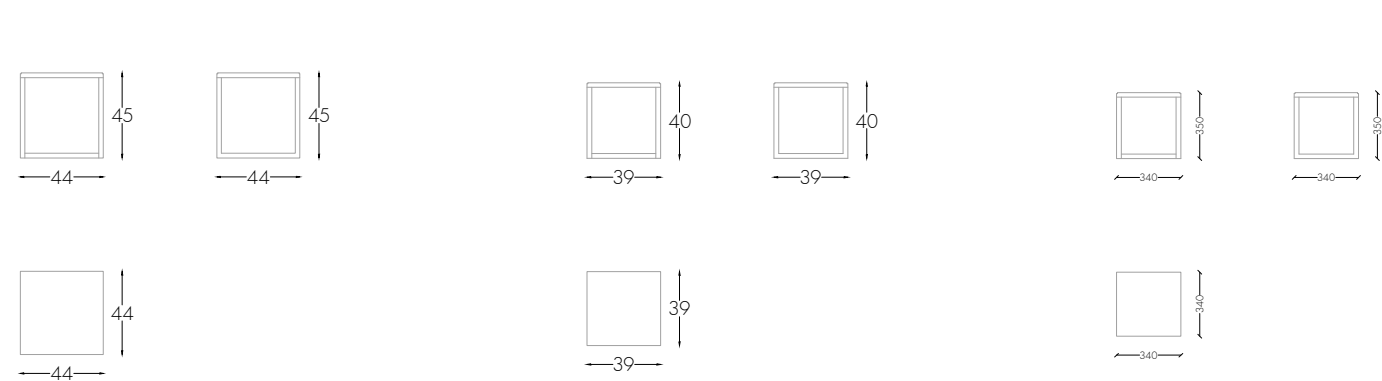

Park

TAVOLINO - COFFEE TABLE

00180 - l. 60 x 53 x h. 45 cm
00180/M - l. 40 x 36 x h. 40 cm
00180/P - l. 32 x 29 x h. 35 cm

Struttura in ottone finitura titanio,
top in marmo.

Burnished brass structure with titanium finish,
marble top.

PAG.
Vol.1 - 170, 172, 213
Vol.2 - 63

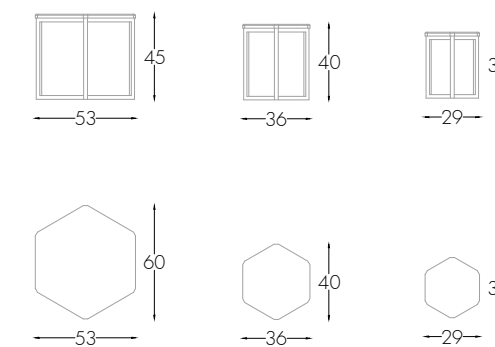

Rietveld

TAVOLINO - COFFEE AND SIDE TABLE

00200/G - Ø 90 x h. 30 cm
00200/M - Ø 60 x h. 43 cm
00200/P - Ø 50 x h. 56 cm

Struttura in ottone brunito,
top in marmo.

Burnished brass structure,
marble top.

PAG.
Vol.1 - 158, 159

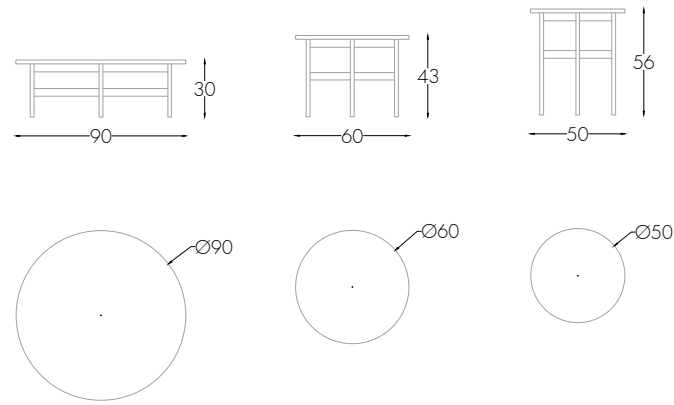

Buddha Bar

TAVOLINO - COFFEE AND SIDE TABLE

00201/G - l. 120 x p. 78 x h. 35 cm
00201/M - l. 78 x p. 78 x h. 35 cm
00201/P - l. 45 x p. 45 x h. 45 cm

Struttura in ottone brunito,
top in marmo.

Burnished brass structure,
marble top.

PAG.
Vol.1 - 145, 156, 157

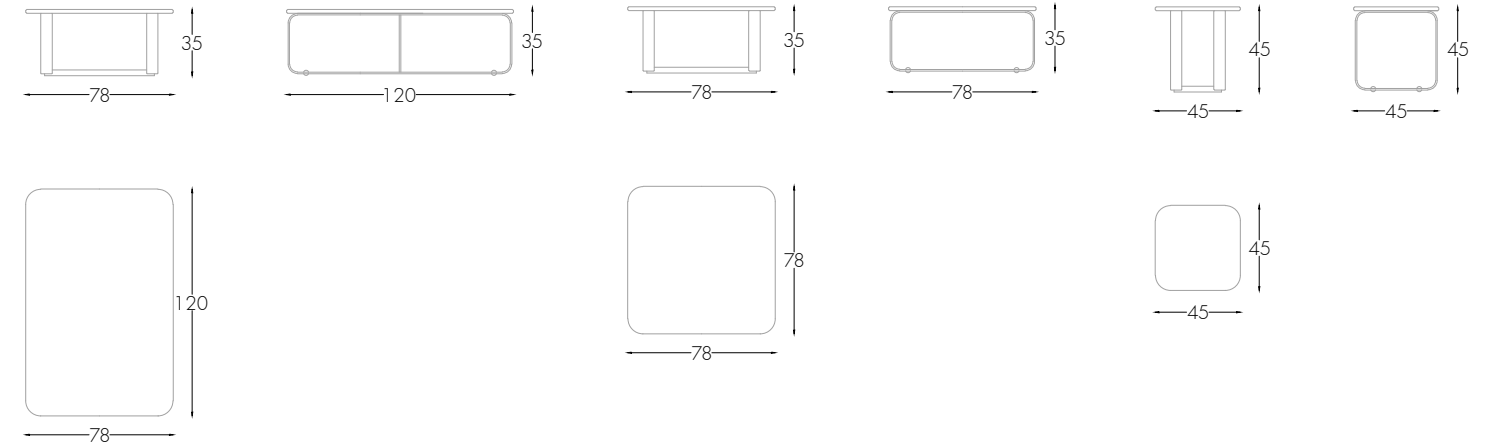

Gaudi

TAVOLINO - SIDE TABLE

00199/G - Ø 60 x h. 45 cm
00199/M - Ø 40 x h. 55 cm

Struttura in ottone brunito,
top in marmo.

Burnished brass structure,
marble top.

PAG.
Vol.1 - 160, 161

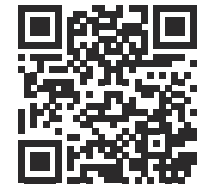
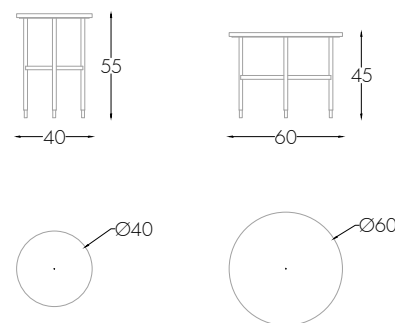

Virgilio

TAVOLINO - COFFEE TABLE

00069/M - Ø 70 x h. 30 cm
00069/G - Ø 70 x h. 55 cm
00069/B - Ø 45 x h. 45 cm

Tavolo in legno massello di acero.
Finitura lucida spazzolata.
Top in marmo.

Table in solid maple.
Brushed glossy finish. Marble top.

PAG.
Vol.1 - 163, 254, 368

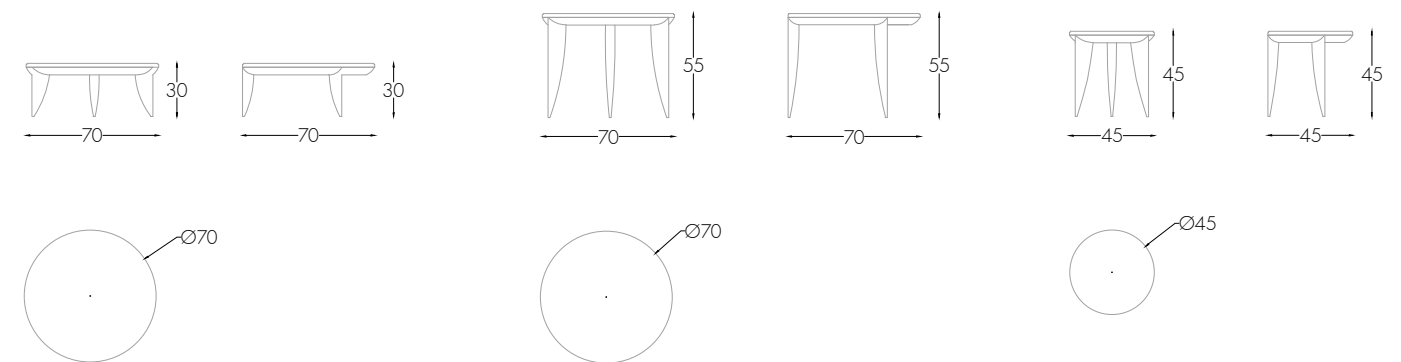

Dante

TAVOLINO - COFFEE TABLE

00070 - l. 45 x p. 45 x h. 45 cm
 00070/M - l. 45 x p. 45 x h. 65 cm
 00070/G - l. 140 x p. 75 x h. 35 cm

Tavolo in legno massello di acero.
 Finitura lucida spazzolata. Top in marmo.

Table in solid maple.
 Brushed glossy finish. Marble top.

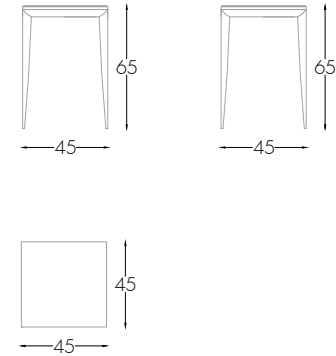
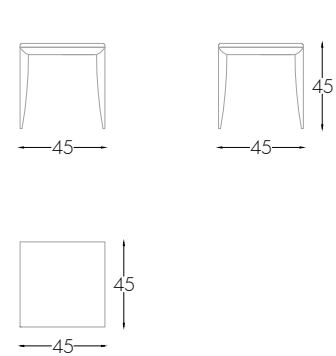

Rondò

TAVOLINO - COFFEE TABLE

00146 - Ø 90 x h. 30 cm
 00146/M - Ø 60 x h. 40 cm
 00146/P - Ø 40 x h. 50 cm

Basamento in legno massello tornito con finitura effetto ottone brunito, top in multistrati con foderina noce dark e particolare in finitura laccata ottone brunito al centro.

Turned solid wood base with burnished brass effect finish, plywood top with dark walnut veneer and burnished brass lacquered finish in the centre.

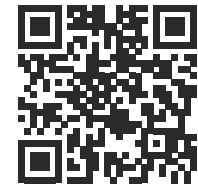
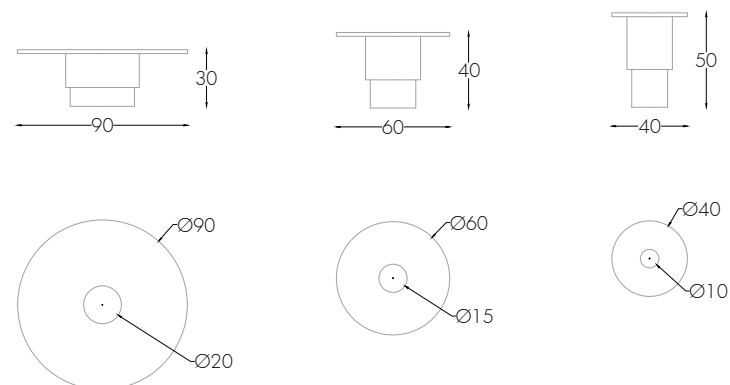

PAG.
 Vol.1 - 162, 163, 164, 166, 167, 203
 Vol.2 - 68, 69

Darko

TAVOLINO - COFFEE TABLE

00257 - l. 140 x p. 140 x h. 35 cm

Gambe in multistrati con foderina frassino 10/10, laccato nero opaco a poro aperto. Telaio di giunzione sottopiano in tubolare di acciaio finitura nero opaco. Top marmo.

Plywood legs lined with 10/10 ashwood veneer, open-pore opaque black finish. Subcounter joining frame in tubular steel with opaque black finish. Marble top.

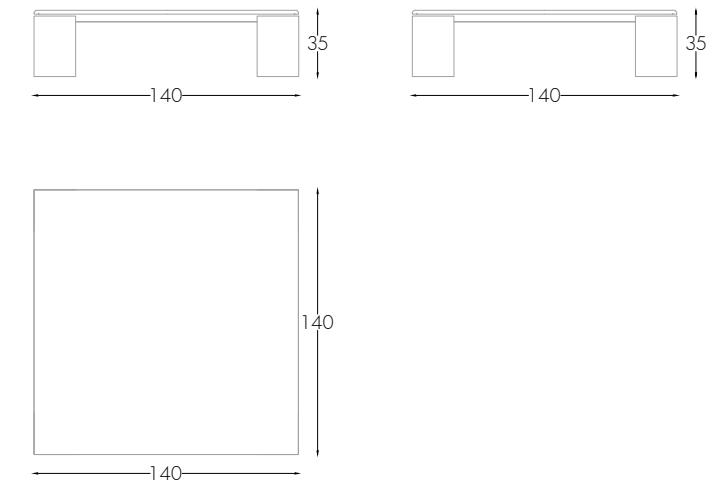

PAG.
 Vol.1 - 76, 77, 82, 83, 84, 123

Paride

TAVOLINO - COFFEE TABLE

00246 - l. 180 x p. 70 x h. 30 cm

Piano in multistrati con foderina di frassino 10/10 laccato nero opaco a poro aperto. Sottopiano in multistrati laccato nero opaco. Basi in legno massello con lamina in ottone satinato.

Plywood counter with 10/10 ashwood veneer, open-pore opaque black lacquered finish. Plywood subcounter with opaque black lacquered finish. Solid wood bases with satin brass laminate.

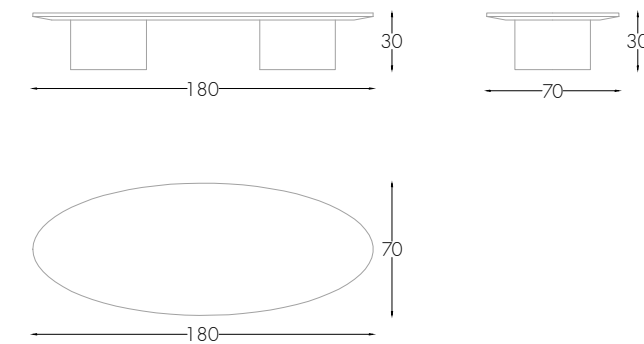

PAG.
 Vol.1 - 62, 63, 140, 141, 142, 143

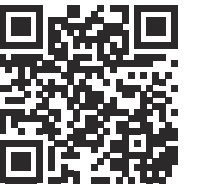

Argo

TAVOLINO - COFFEE TABLE

00240 - l. 150 x p. 66 x h. 21,5 cm

Struttura in lamiera di acciaio laccato fumo opaco, top in vetro laccato nero spessore 20 mm, con molatura asimmetrica.

Steel sheet structure with opaque smoke-lacquered finish, 20 mm black asymmetric grinded glass top.

PAG.

Vol.1 - 44, 45, 47, 48, 49, 58, 59

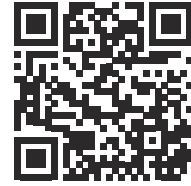
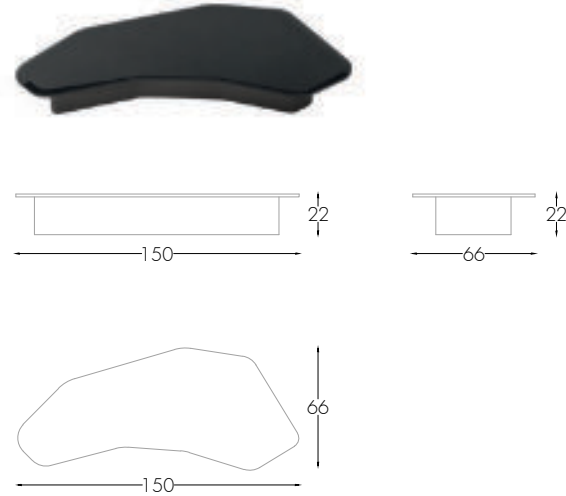

Kensington

TAVOLINO - COFFEE TABLE

00087 - l. 150 x p. 80 x h. 35 cm
00087/G - l. 150 x p. 150 x h. 35 cm

Struttura in multistrati curvato con foderina noce dark, top in marmo. Finitura lucida spazzolata.

Curved plywood structure with dark walnut veneer, marble top. Brushed glossy finish.

PAG.

Vol.1 - 220, 221, 266, 267, 270

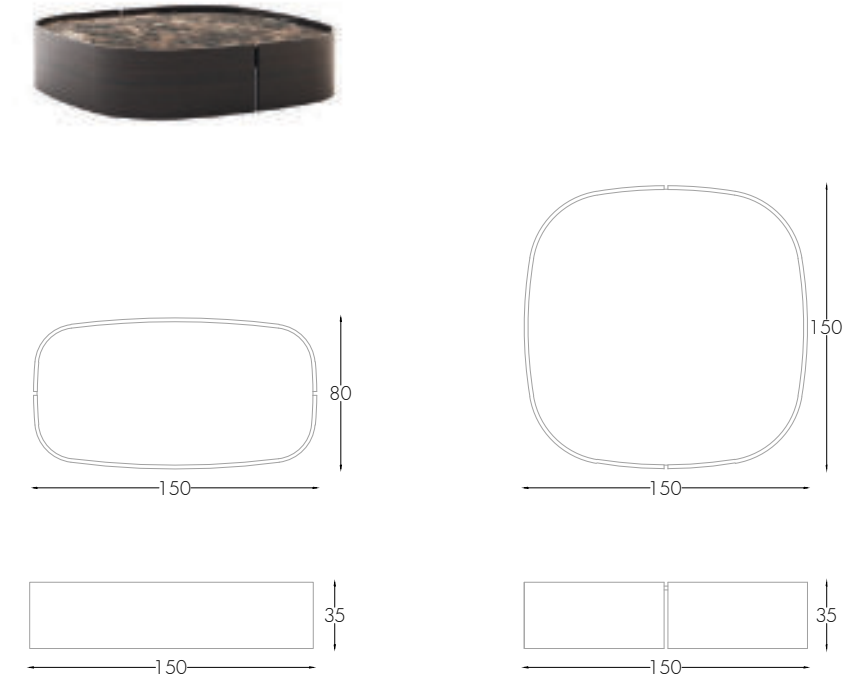

Lipari

TAVOLINO - COFFEE TABLE

00202 - L. 90 x p. 90 x h. 22,5 cm

Struttura in multistrati rivestita in pelle, basamento in multistrati rivestito in lamina ottone brunito, top in marmo.

Plywood structure covered in leather, plywood base covered with burnished brass lamina, marble top.

PAG.

Vol.1 - 144, 145, 150, 151, 152

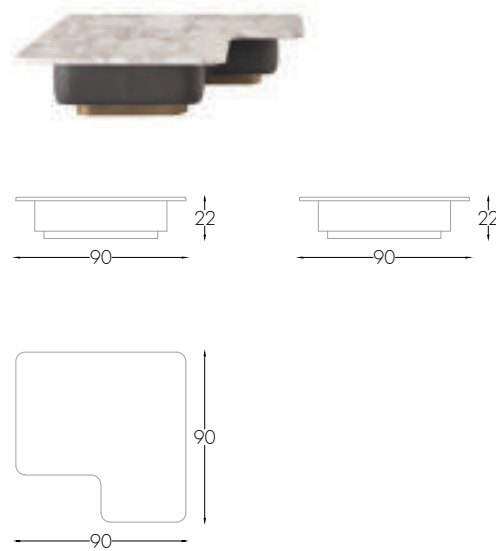

Giove

TAVOLINO - COFFEE TABLE

00058 - Ø 130 x h. 42 cm

Tavolino con struttura in multistrati foderato in pelle con trapuntatura cannettè e parti inferiori in ottone brunito. Top in marmo.

Coffee table with plywood structure covered in leather quilted with cannettè motive and lower parts in burnished brass. Marble top.

PAG.

Vol.1 - 235, 240, 241

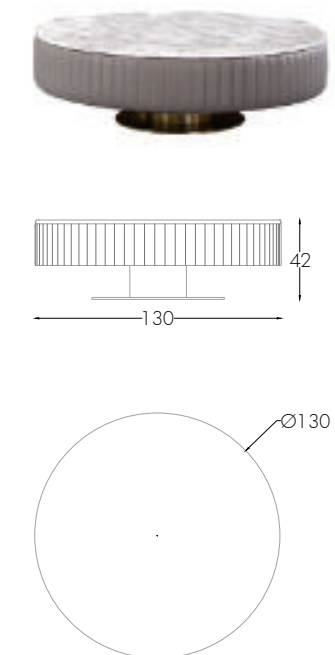

Otto

TAVOLINO - COFFEE TABLE

00129 - l. 80 x p. 80 x h. 40 cm

Struttura in multistrati con foderina noce dark, due cassetti tappezzati in tessuto con guide soft metalliche ed apertura push pull. Finitura lucida spazzolata.

Plywood structure with dark walnut veneer, two fabric lined drawers with soft metal runners and push-pull opening. Brushed glossy finish.

PAG.
Vol.1 - 68, 69, 170, 171, 173, 178, 179, 182
Vol.2 - 80, 81

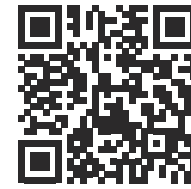
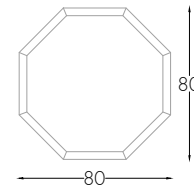
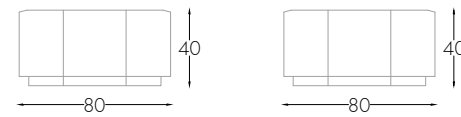

Vasari

TAVOLINO CON CASSETTI - COFFEE TABLE WITH DRAWERS

00186/C - l. 150 x p. 70 x h. 35 cm

Struttura in multistrati con foderina noce dark, base in multistrati finitura effetto ottone brunito. Finitura lucida spazzolata, con 2 cassetti tappezzati in tessuto e guide soft metalliche.

Plywood structure with dark walnut veneer, burnished brass effect finish plywood base. Brushed glossy finish, with 2 fabric lined drawers and soft metal runners.

PAG.
Vol.1 - 224, 225, 226, 227

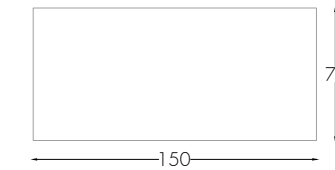
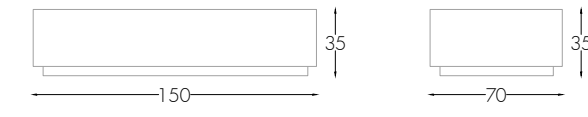

Vasari

TAVOLINO - COFFEE TABLE

00186 - l. 150 x p. 70 x h. 35 cm

Struttura in multistrati con foderina noce dark, base in multistrati finitura effetto ottone brunito. Finitura lucida spazzolata.

Plywood structure with dark walnut veneer, burnished brass effect finish plywood base. Brushed glossy finish.

PAG.
Vol.1 224, 225

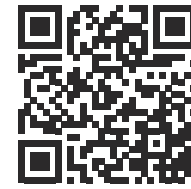
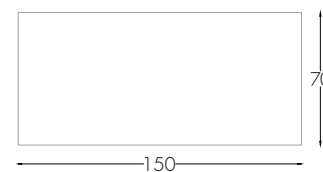
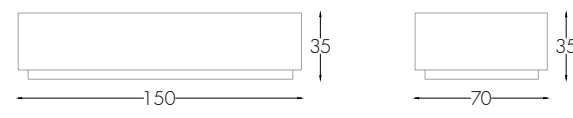

Fayette

CONSOLLE - CONSOLE

00239 - l. 140 x p. 45 x h. 78,3 cm

Struttura in tubolare ottone finitura satinata. Top e ripiano in vetro fumé.

Tubular satin brass structure. Smoke-grey glass top and shelf.

PAG.
Vol.1 - 44, 45, 48, 60, 61

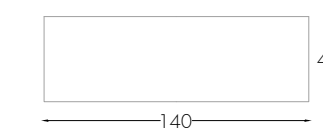
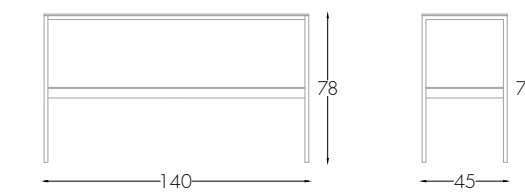

Colette

CONSOLLE - CONSOLE

00277 - l. 150 x p. 35,8 x h. 75 cm

Struttura in tubolare ottone finitura satinata.
Top in marmo.

Tubular satin brass structure.
Marble top.

PAG.
Vol.1 - 90, 91

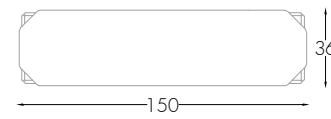
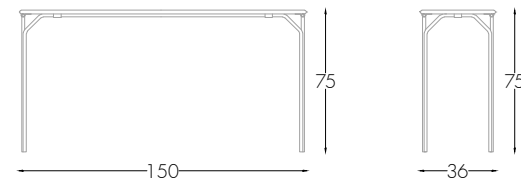

Misia

CONSOLLE - CONSOLE

00253 - l. 140 x p. 40 x h. 75 cm

Struttura in tubolare di ottone, top in multistrati
foderato con lamina ottone e cuoio.
Finitura ottone satinato.

Tubular brass structure, plywood top with brass
laminated and leather. Satin brass finish.

PAG.
Vol.1 - 105, 106

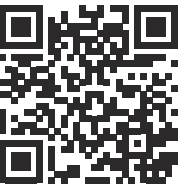
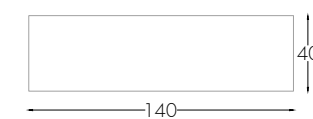
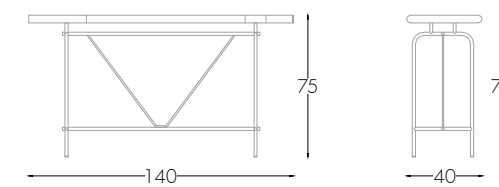

Colette

RETRODIVANO - SOFA BACKBOARD

00245 - l. 180 x p. 40 x h. 45 cm

Struttura in tubolare ottone finitura satinata.
Top in marmo.

Tubular satin brass structure.
Marble top.

PAG.
Vol.1 - 89

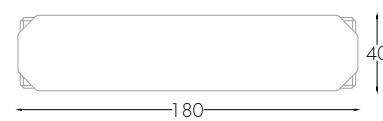
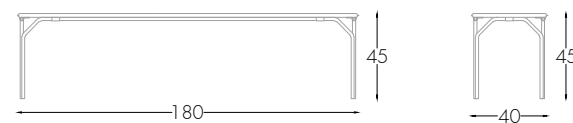

Angelina

CONSOLLE - CONSOLE

00077 - l. 150 x p. 40 x h. 75 cm

Struttura in radica di mirto, due cassetti tappezzati
in tessuto con guide soft metalliche. Cassetti con
trapuntatura cannetté. Basamento e maniglie in
ottone brunito e top in marmo.

Myrtle burl structure, two fabric lined drawers
with soft metal runners. Drawer fronts quilted with
cannetté motive. Base and handles in burnished
brass, marble top.

PAG.
Vol.1 - 248, 249, 250, 251, 253

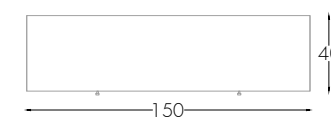
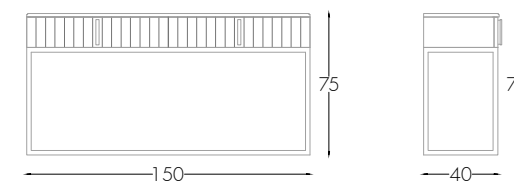

Josephine

CONSOLLE - CONSOLE

00096 - l. 125 x p. 40 x h. 75 cm

Struttura in ottone brunito.
Top in marmo.

Burnished brass structure.
Marble top.

PAG.
Vol.1 - 264

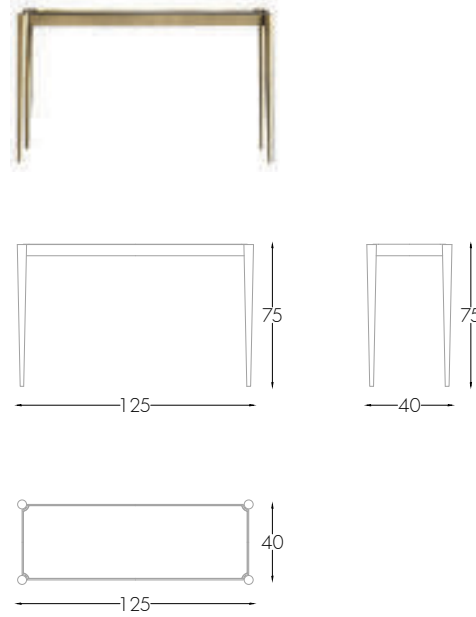

Weybridge

CONSOLLE - CONSOLE

00152 - l. 140 x p. 40 x h. 75 cm

Top in multistrati con foderina noce dark finitura lucida spazzolata. Gambe in ottone brunito.

Plywood top with dark walnut veneer, brushed glossy finish. Burnished brass legs.

PAG.
Vol.1 - 180, 181

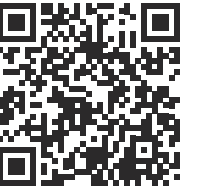
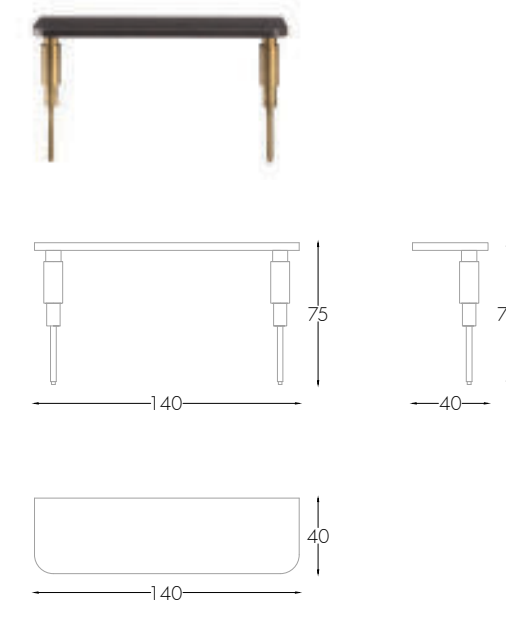

Monogram

CONSOLLE - CONSOLE

00014 - l. 140 x p. 45 x h. 77 cm

Base e top in multistrati, finitura lucida spazzolata, struttura in ottone brunito.

Plywood base and top, brushed glossy finish, burnished brass structure.

PAG.
Vol.1 - 275, 276

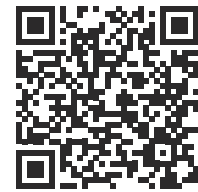
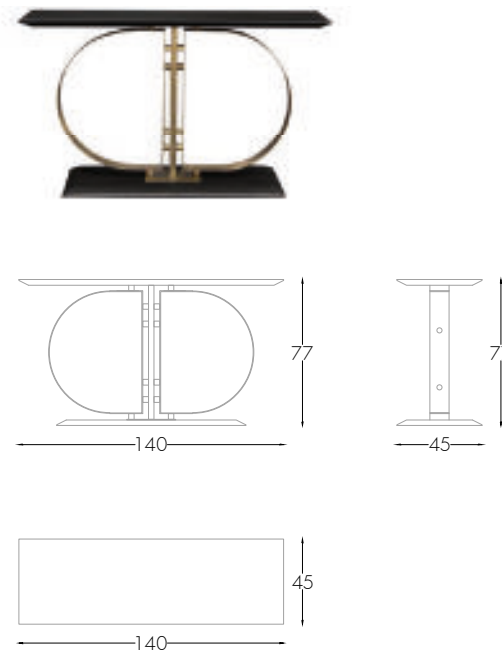

Dante

CONSOLLE - CONSOLE

00140 - l. 160 x p. 45 x h. 80 cm

Struttura in multistrati con foderina noce dark, due cassetti tappezzati in tessuto, con guide soft metalliche, maniglie in ottone brunito. Gambe in noce massello. Finitura lucida spazzolata.

Plywood structure with dark walnut veneer, two lined drawers, with soft metal runners, brass handles with burnished brass finish. Solid walnut base, brushed glossy finish.

PAG.
Vol.1 - 198

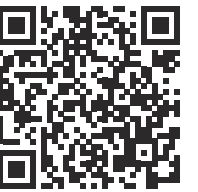

Ludus

CONSOLLE - CONSOLE

00149 - l. 180 x p. 40 x h. 70 cm

Struttura in multistrati laccata lucida spazzolata, cassetto tappezzato in tessuto con guide soft metalliche, frontale cassetto con lavorazione a trama ondulata, finitura foglia argento patinata lucida spazzolata. Basamento a specchio brunito e top vetro fumé.

Lacquered plywood structure, lined drawers, with soft metal runners, drawer fronts with wavy pattern, brushed glossy finish with silver leaf, burnished mirror base, smoked glass top.

PAG.
Vol.1 - 204, 205, 206

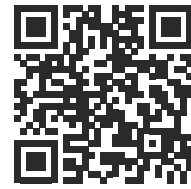
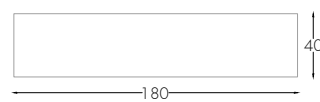
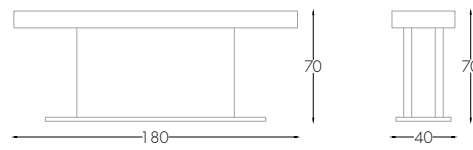

Jubilee

CONSOLLE - CONSOLE

00145 - l. 150 x p. 45 x h. 85 cm

Struttura in multistrati con foderina noce dark, finitura lucida spazzolata, cassetto tappezzato in tessuto, con guide soft metalliche, frontale cassetto con lavorazione a trama ondulata, finitura foglia oro lucida spazzolata, schienali a specchio brunito.

Plywood structure with dark walnut veneer, brushed glossy finish, lined drawers, with soft metal runners, drawer fronts with wavy pattern, brushed glossy finish with gold leaf, burnished mirror backs.

PAG.
Vol.1 - 192, 193, 196, 197

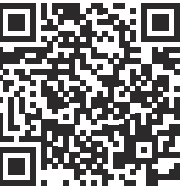
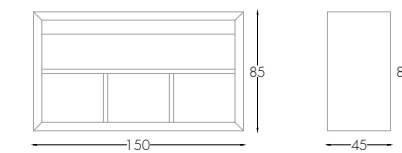

Byron

CONSOLLE - CONSOLE

00155 - l. 160 x p. 40 x h. 80 cm

Basamento in legno massello di tiglio con trapuntatura cannetté, base in acciaio finitura titanio. Top in marmo.

Solid linden wood base quilted with cannetté motive, lower part of the base in steel with titanium finish. Marble top.

PAG.
Vol.1 - 209, 210, 211

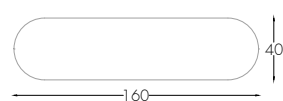
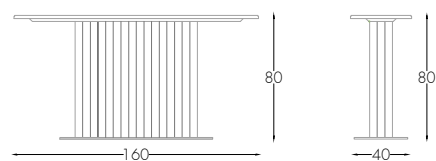

Carlton

LIBRERIA CON PORTA TV - BOOKCASE WITH TV STAND

00204 - l. 550 x p. 50 x h. 226 cm

Struttura in multistrati, schienali rivestiti in econabuk, retro illuminazione a led nei fianchi esterni ed ante nei vani laterali. Finitura laccata lucida spazzolata.

Plywood structure, backs covered in eco nabuk, led lights in the external side panels and doors in the lateral compartments. Lacquered brushed glossy finish.

PAG.
Vol.1 - 144, 154, 155

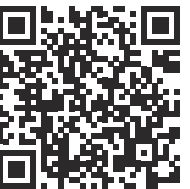
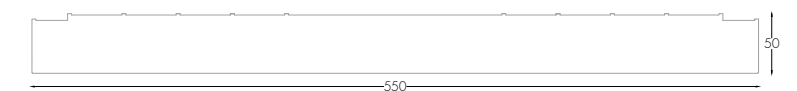
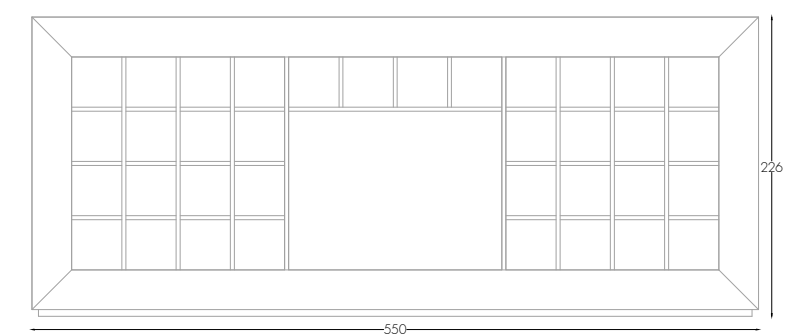

Zeus

MOBILE TV - TV CABINET

00190/P - l. 250 x p. 50 x h. 250 cm

Struttura in multistrati con foderina radica di mirto, interno cassetti tappezzati in tessuto, guide soft metalliche, frontale cassetti con trapuntatura a rombi, elementi di sostegno laterali in ottone finitura ottone brunito. Maniglie in ottone finitura ottone brunito e pelle. Pannello porta lcd con cornice in radica di mirto e pannello rivestito in pelle o tessuto.

Plywood structure with myrtle burl veneer, fabric lined drawer interiors, soft metal runners, quilted drawer fronts, supporting lateral elements in brass with burnished brass finish. Handles in brass with burnished brass finish and leather. LCD panel with myrtle burl frame and panel upholstered in leather or fabric.

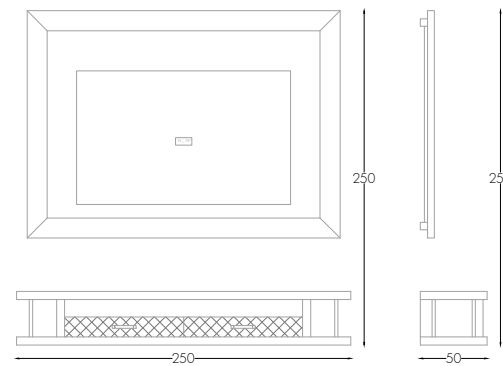

PAG.
Vol.1 - 214, 215

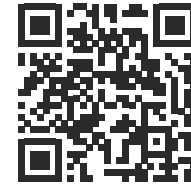

Zeus

BASE MOBILE TV - TV CABINET BASE

00190 - l. 250 x p. 50 x h. 40 cm

Struttura in multistrati con foderina radica di mirto, lucida spazzolata. Interno cassetti tappezzati in tessuto, guide soft metalliche, frontale cassetti con trapuntatura a rombi, elementi di sostegno laterali in ottone finitura ottone brunito. Maniglie in ottone finitura ottone brunito e pelle.

Plywood structure with brushed lacquered myrtle burl veneer, fabric lined drawer interiors, soft metal runners, quilted drawer fronts, supporting lateral elements in brass with burnished brass finish. Handles in brass with burnished brass finish and leather.

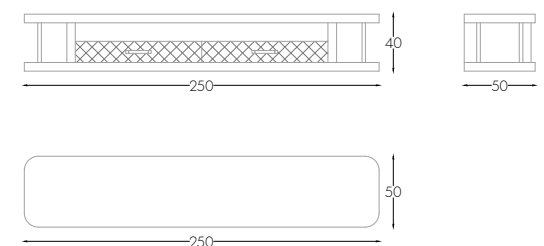

PAG.
Vol.1 - 214, 215, 216, 217, 218, 219

Hamilton

PORTA TV - TV CABINET

00046/P - l. 240 x p. 50 x h. 190 cm

PANNELLI PORTA LCD - LCD PANEL

l. 160 x p. 25 x h. 100 cm

Struttura in multistrati con foderina noce dark interno ed esterno. Anta scorrevole con trapuntatura cannetté. Maniglia in ottone finitura ottone brunito. Schienale rivestito in pelle e pannello porta TV in noce dark.

Plywood structure with internal and external dark walnut veneer. Sliding door quilted with cannetté motive. Handles in brass with burnished brass finish. Back covered in leather, TV panel in dark walnut.

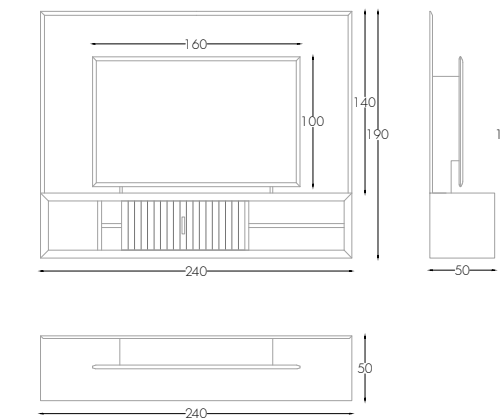

PAG.
Vol.1 - 220, 221, 222, 223

Hamilton

PORTA TV - TV CABINET

00046 - l. 240 x p. 50 x h. 50 cm

Struttura in multistrati con foderina radica di mirto interno ed esterno. Anta scorrevole con trapuntatura cannetté. Maniglia in ottone finitura ottone brunito.

Plywood structure with internal and external myrtle burn veneer. Sliding door quilted with cannetté motive. Handles in brass with burnished brass finish.

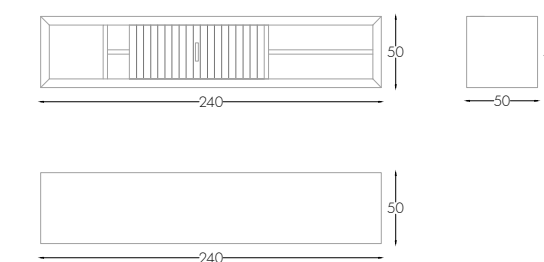

PAG.
Vol.1 - 220, 221, 222, 223



Vermont

LIBRERIA CON PORTA TV - BOOKCASE WITH TV STAND

00020/S - l. 360 x p. 55 x h. 224 cm

Struttura in multistrati con foderina noce dark, assemblaggio con tecnica folding. Ante finitura lucida spazzolata. Cerniere ante con chiusura soft. Maniglie in ottone finitura ottone brunito e pelle.

Plywood structure with dark walnut veneer, assembled using folding technique. Doors with brushed glossy finish. Doors with soft-closing hinges. Handles in brass with burnished brass finish and leather.

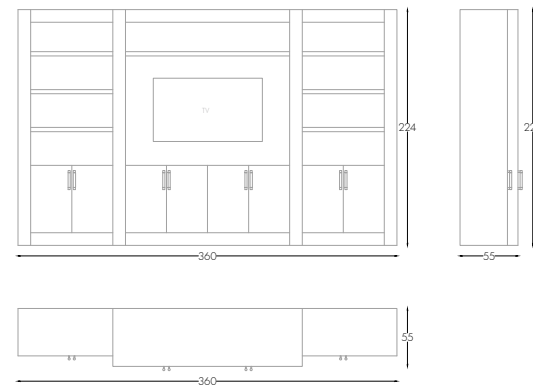

Babel

LIBRERIA - BOOKCASE

00189 - l. 120 x p. 40 x h. 200 cm

Struttura con ripiani tamburati in radica di mirto, finitura lucida spazzolata. Struttura in ottone brunito.

Hollow-core shelves with myrtle burl veneer, brushed glossy finish. Structure in burnished brass.

PAG.
Vol.1 - 228, 229, 334, 336

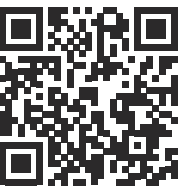
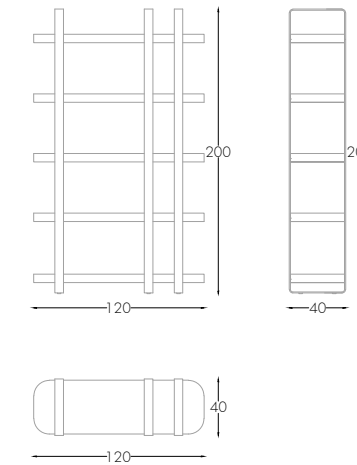

Black Tie

PORTA TV - TV CABINET

00057 - l. 200 x p. 50 x h. 210 cm

Struttura in multistrati con foderina radica di mirto, maniglie in ottone finitura ottone brunito. Cassetti tappezzati in tessuto, guide soft metalliche. Cornice in acero massello. Frontale ribalta con trapuntatura cannetté. Finitura lucida spazzolata.

Plywood structure with myrtle burl veneer, handles in brass with burnished brass finish. Lined drawers with soft metal runners. Drop-down front quilted with cannetté motive. Brushed gloss finish.

PAG.
Vol.1 - 244, 245

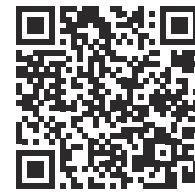
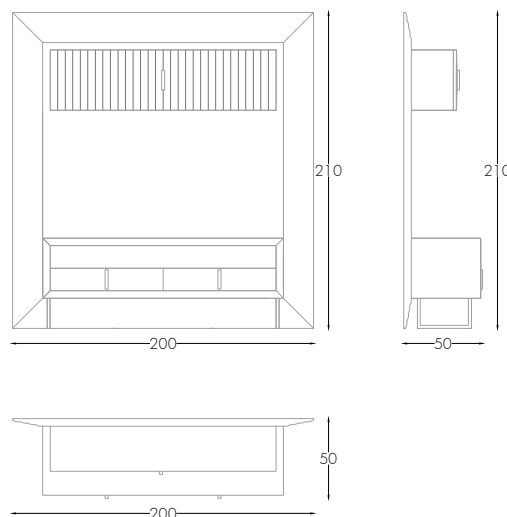

Espace

LIBRERIA COMPONIBILE - CUSTOM BOOKCASE

00071 - l. 195 x p. 30 x h. 366 cm
l. 195 x p. 30 x h. 150 cm

Struttura con ripiani tamburati in radica di mirto o noce dark, finitura lucida spazzolata o opaca. Distanziali in ottone finitura ottone brunito.

Structure with hollow-core shelves in myrtle or dark walnut, brushed glossy or matt finish. Spacers in brass with burnished brass finish.

PAG.
Vol.1 - 230, 231, 232, 233, 262

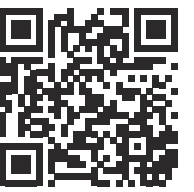
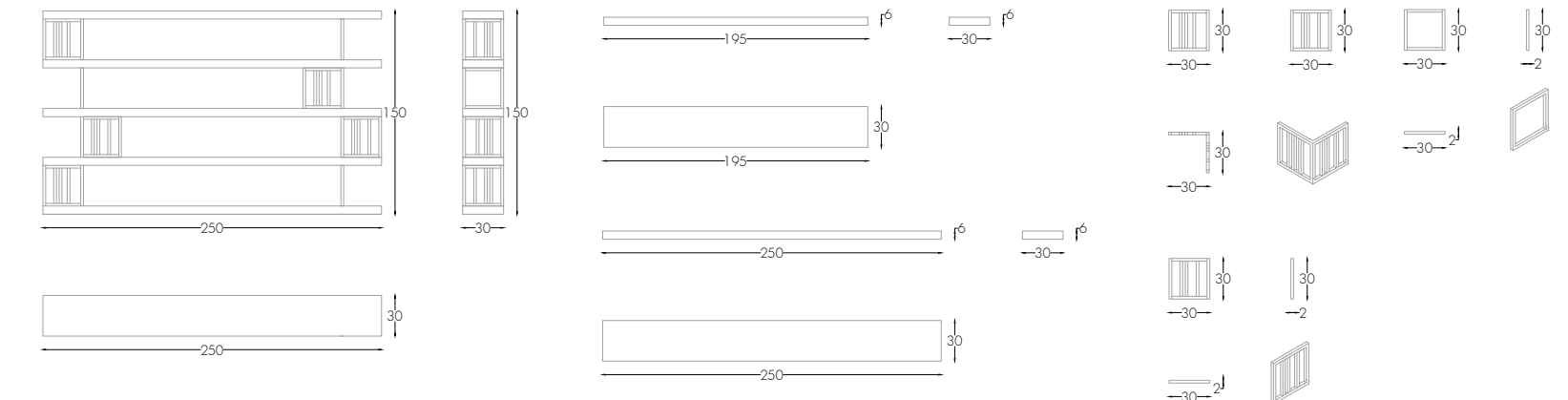
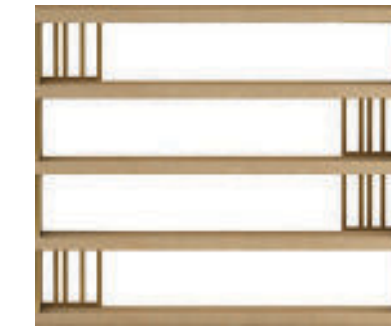

Moustique

MOBILE BAR - BAR CABINET

00247 - l. 80 x p. 45 x h. 151 cm

Struttura in multistrati, rivestita in pelle, interno laccato fumo opaco con ripiani legno e led.
Maniglia logo in acciaio finitura nero opaco, basamento in acciaio finitura nero opaco.

Plywood structure, covered with leather, smoke-grey lacquered interior with wooden shelves and led.
Steel logo handle with opaque black finish, base in opaque black steel.

PAG.
Vol.1 - 77, 83, 98, 99

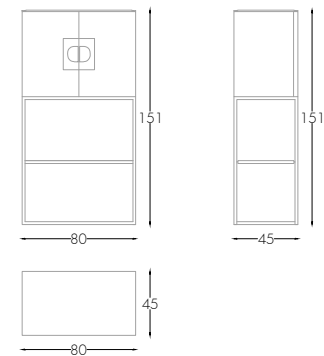

Monsieur

MOBILE BAR - BAR CABINET

00051 - l. 110 x p. 40 x h. 160 cm

Struttura in multistrati con foderina radica di mirto, maniglie in ottone brunito. Frontale ribalta con trapuntatura cannotté. Finitura lucida spazzolata. Basamento in ottone finitura ottone brunito o titanio.

Plywood structure with myrtle burl veneer, handles in burnished brass. Drop-down front quilted with cannotté motive. Brushed glossy finish. Base in brass with burnished brass or titanium finish.

PAG.
Vol.1 - 354, 355, 356, 357

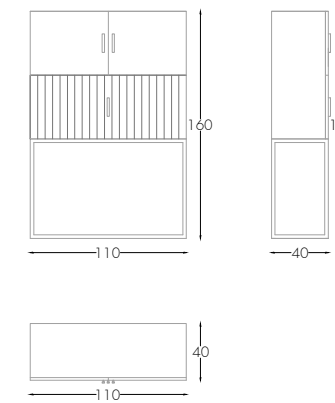

Vega

MOBILE BAR - BAR CABINET

00255 - l. 90 x p. 50 x h. 167 cm

Struttura in multistrati, rivestita in pelle, interno laccato fumo opaco con ripiani legno e led.
Basamento in acciaio finitura nero opaco. Cassetto interno tappezzato con chiusura ed apertura blu motion push soft.

Plywood structure, covered with leather, smoke-grey lacquered interior with wooden shelves and led.
Steel base with opaque black finish. Upholstered interior drawers with soft blue push-push closing and opening.

PAG.
Vol.1 - 68, 69, 72, 74, 75

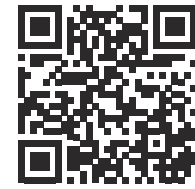
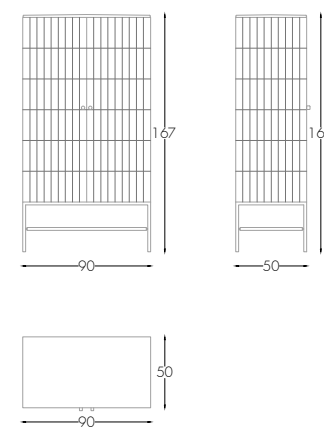

Zeus

MOBILE BAR - BAR CABINET

00191 - l. 140 x p. 69 x h. 190 cm

Struttura in multistrati con foderina radica di mirto, schienale vano superiore con vetro e specchio fumé, vano frigo lato destro, ante e cassetti rivestiti con trapuntatura a rombi, cerniere in profilato di ottone brunito, interno cassetti tappezzati in tessuto con guide soft metalliche. Vassoio porta bicchieri rivestito e sospensioni in ottone brunito.

Plywood structure with myrtle burl veneer, upper compartment back with glass and smoked mirror, refrigerator compartment on the right side, diamond quilting on doors and drawers, burnished brass hinges, fabric lined drawer interiors, soft metal runners. Upholstered glass holder tray and burnished brass suspensions.

PAG.
Vol.1 - 352, 353

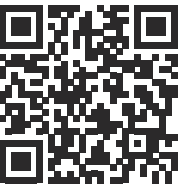
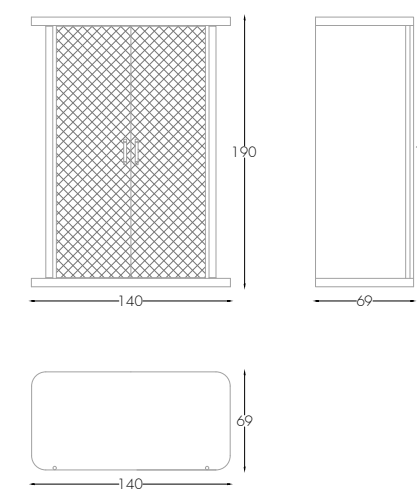

Harris

MOBILE BAR - BAR CABINET

00150 - l. 122 x p. 42 x h. 172 cm

Struttura in tamburato con foderina noce dark, finitura lucida spazzolata. Ribalta con trapuntatura cannetté, cassettera interna tappezzata in tessuto con guide soft metalliche, led e schienali a specchio naturale.

Hollow-core structure with dark walnut veneer, brushed glossy finish. Drop-down front quilted with cannetté motive, fabric lined internal drawers with soft metal runners, internal LEDs and natural mirror backs.

PAG.
Vol.1 - 187, 342, 343, 348, 350, 351

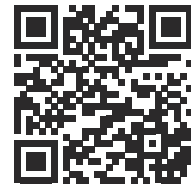
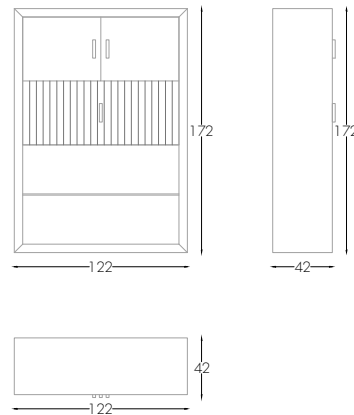

Moustique

CREDENZA - SIDEBBOARD

0321 - l. 180 x p. 55 x h. 70 cm

Struttura in multistrati, rivestita in pelle, interno laccato fumo opaco. Due cassetti interni tappezzati con apertura push soft. Maniglia logo in acciaio finitura nero opaco, basamento in acciaio finitura nero opaco, top vetro laccato nero.

Plywood structure, leather coated, matt smoke lacquered interior. Two internal drawers with push soft opening. Logo steel handle matt black finish, steel finish matt black finish, black lacquered glass top.

PAG.
Vol.1 - 100, 101, 102, 103

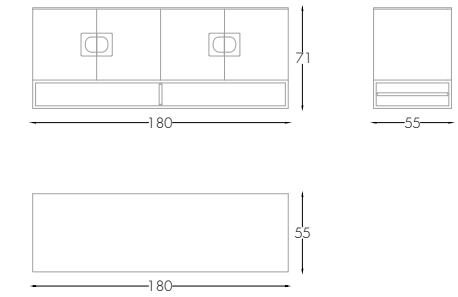

Madame

VETRINA - SHOWCASE

00130 - l. 100 x p. 50 x h. 180 cm

Struttura in multistrati con foderina radica di mirto, maniglie in ottone brunito. Finitura lucida spazzolata. Basamento in ottone brunito. Faretti interni. Ripiani in cristallo, schienale a specchio naturale.

Plywood structure with dark walnut veneer, handles in burnished brass. Brushed glossy finish. Base in burnished brass. Internal spotlights. Glass shelves. Natural mirror back.

PAG.
Vol.1 - 368, 370, 371

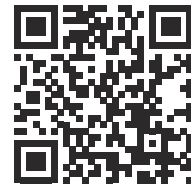
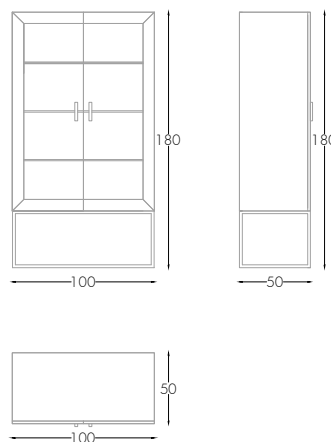

Mizar

CREDENZA - SIDEBBOARD

00231 - l. 120 x p. 50 x h. 96 cm

Struttura in multistrati, rivestita in pelle, interno laccato opaco con ripiani legno. Top vetro laccato nero, basamento in acciaio finitura nero opaco. Cassetti interni tappezzati con chiusura ed apertura blu motion push soft.

Plywood structure, covered with leather, opaque lacquered interior with wooden shelves. Black lacquered glass top, steel base with opaque black finish. Upholstered interior drawers with soft blue push-push closing and opening.

PAG.
Vol.1 - 290, 295, 296, 297, 298, 299

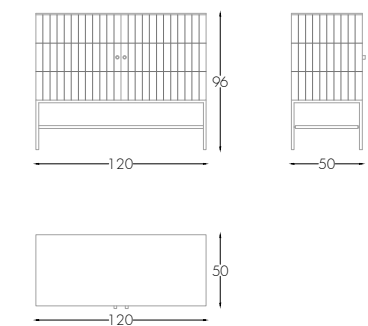

Square

CREDENZA - SIDEBOARD

00228 - l. 240 x p. 55 x h. 73 cm

Struttura in multistrati con foderina frassino 10/10, interno ed esterno. finitura nero opaco a poro aperto. Guide e cerniere soft metalliche, basamento in multistrati curvato foderato con lamina in ottone satinato, 2 cassetti interni tappezzati in tessuto, top in legno.

Plywood structure with internal and external ashwood 10/10 veneer. Open-pore opaque black finish. Soft runners and zips, curved plywood base lined with satin brass laminate, 2 internal drawers lined in fabric, wooden top.

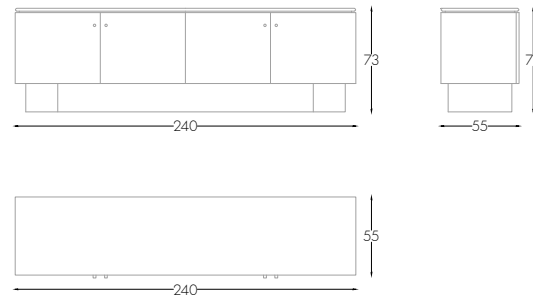

PAG.
Vol.1 92, 93, 94, 95, 96, 97

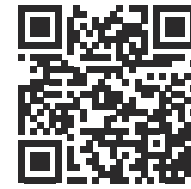

Antibes

VETRINA - SHOWCASE

00151 - l. 100 x p. 50 x h. 146 cm

Struttura in multistrati con foderina noce dark, finitura lucida spazzolata. Ante a vetro, profilo con trapuntatura a trama ondulata finitura foglia oro patinata lucida o finitura lucida effetto titanio. Cassettiera interna tappezzata in tessuto con guide soft metalliche, led e schienali a specchio naturale.

Plywood structure with dark walnut veneer, burnished glossy finish. Glass doors with wavy pattern workmanship, glossy coated gold leaf or glossy titanium effect finishing. Fabric lined internal drawers with soft metal runners. Internal led and mirror back.

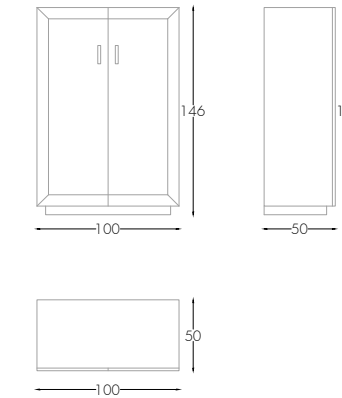

PAG.
Vol.1 - 170, 364, 365



Roger

CREDENZA - SIDEBOARD

00234 - l. 240 x p. 55 x h. 88 cm

Struttura in multistrati con foderina frassino 10/10, interno ed esterno. Finitura nero opaco a poro aperto. Guide e cerniere soft metalliche, basamento in ottone satinato, 2 cassetti interni tappezzati in tessuto, top marmo.

Plywood structure with internal and external ashwood 10/10 veneer. Open-pore opaque black finish. Soft metal runners and zips, satin brass base, 2 internal drawers lined in fabric, marble top.

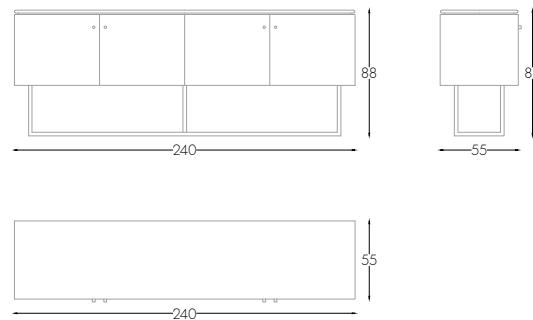

PAG.
Vol.1 - 314, 322, 323, 324, 325, 326, 327

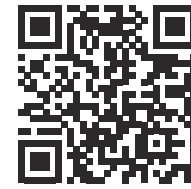

Suite

CREDENZA - SIDEBOARD

00171 - l. 240 x p. 55 x h. 103 cm

Struttura in multistrati con foderina radica di mirto, finitura lucida spazzolata. Cassetti con trapuntatura cannetté, tappezzati in tessuto e con guide soft metalliche. Top in marmo.

Plywood structure with myrtle burl veneer. Brushed glossy finish. Front drawers quilted with cannetté motive. Fabric lined drawers, with soft metal runners. Marble top.

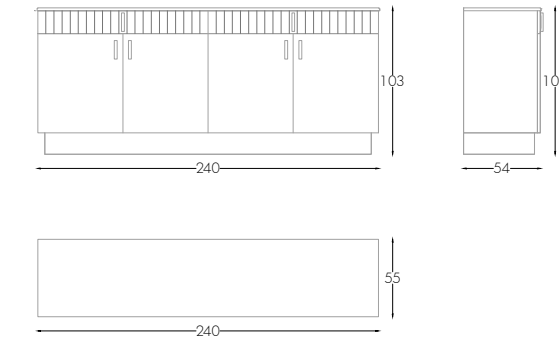

PAG.
Vol.1 - 388, 389, 390, 391, 392, 393



1909

1909
CREDENZA - SIDEBOARD

00052 - l. 200 x p. 55 x h. 80 cm

Struttura in multistrati con foderina radica di mirto, finitura lucida spazzolata. Basamento in ottone brunito. Top in marmo.

Plywood structure with myrtle burl veneer, brushed glossy finish. Base in burnished brass. Marble top.

PAG.
Vol.1 - 330, 331, 366, 367

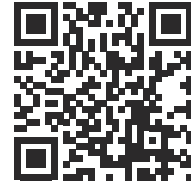
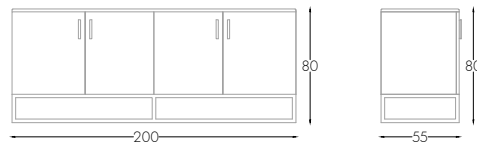

Westminster

CREDENZA - SIDEBOARD

00019 - l. 208 x p. 60 x h. 85 cm

Struttura in multistrati curvato, con foderina di noce dark, interno ed esterno. Finitura lucida spazzolata. Cassetto esterno tappezzati in tessuto con guide soft metalliche. Basamento rivestito con lamina in ottone brunito. Top in marmo.

Curved plywood structure, with inside and outside dark walnut veneer. Brushed glossy finish. External drawer with soft metal runners. Base covered in burnished brass lamina, marble top.

PAG.
Vol.1 375, 376, 377, 379, 380

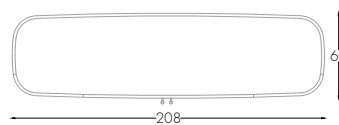
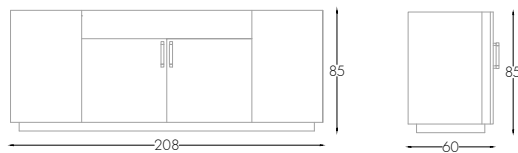

Tobia

TAVOLO - TABLE

00265 - l. 260 x p. 130 x h. 75 cm

Piano in multistrati con foderina frassino da 10/10, basamento in multistrati curvato finitura laccato nero opaco a poro aperto e ottone satinato. Top in ottone satinato.

Plywood counter with 10/10 ashwood veneer, curved plywood base with open-pore opaque black finish and satin brass finish. Satin brass top.

PAG.
Vol.1 318, 319

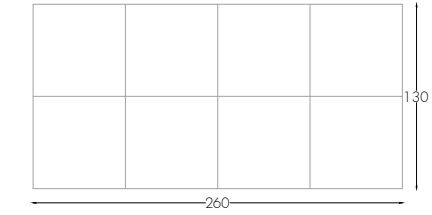
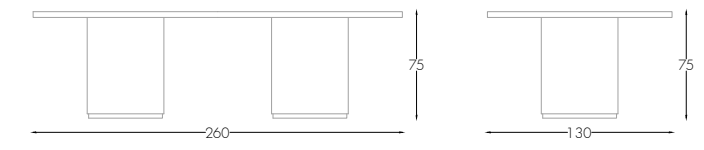

Tobia

TAVOLO - TABLE

00232 - l. 130 x p. 130 x h. 75 cm

Piano in multistrati con foderina frassino da 10/10, basamento in multistrati curvato finitura laccato nero opaco a poro aperto e ottone satinato. Top in ottone satinato.

Plywood counter with 10/10 ashwood veneer, curved plywood base with open-pore opaque black finish and satin brass finish. Satin brass top.

PAG.
Vol.1 - 315, 317

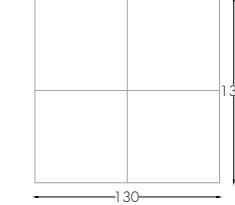
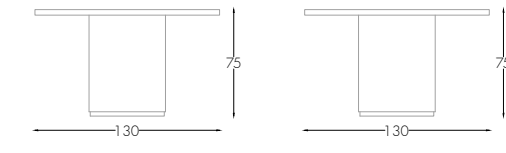

Cigar

TAVOLO - TABLE

00226 - l. 250 x p. 110 x h. 76 cm
00226/G - l. 300 x p. 110 x h. 76 cm

Top in multistrati spessore 40mm con foderina frassino da 10/10, gambe in legno massello di frassino. Finitura laccato nero opaco a poro aperto. Dettagli gambe in ottone satinato. Top marmo.

Plywood top 40 mm thick with 10/10 ashwood veneer, legs in solid ashwood. Open-pore lacquered opaque black finish. Leg details in satin brass. Marble top.

PAG.
Vol.1 - 308, 309, 310, 311

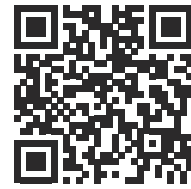
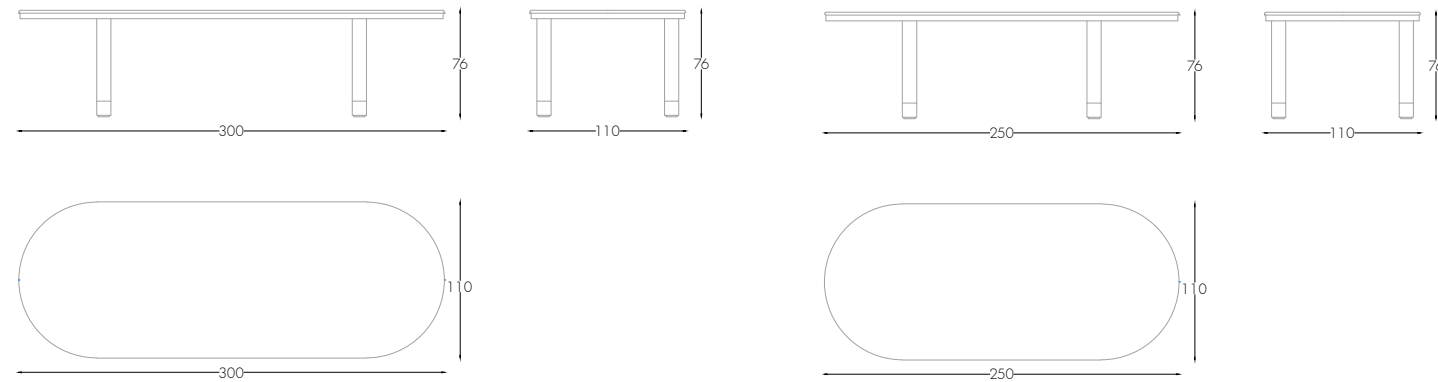

Darko

TAVOLO - TABLE

00235 - l. 160 x p. 160 x h. 75 cm

Gambe in multistrati con foderina frassino 10/10, laccato nero opaco a poro aperto. Telaio di giunzione sottopiano in tubolare di acciaio finitura nero opaco. Top in marmo.

Plywood legs lined with 10/10 ashwood veneer, open-pore opaque black finish. Subcounter joining frame in tubular steel with opaque black finish. Marble top.

PAG.
Vol.1 - 68, 69, 301, 302

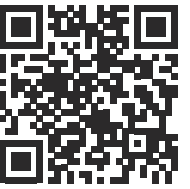
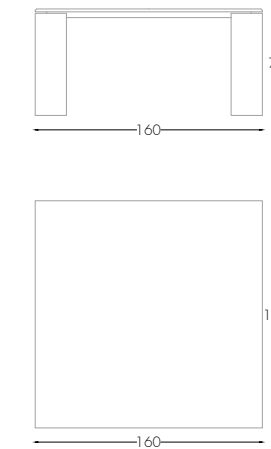

Bramante

TAVOLO - TABLE

00229 - Ø 180 x h. 76 cm

Struttura base in multistrati curvato con lamina in ottone satinato. Top con Lazy Susan incassato. Finitura laccato. A richiesta si può avere meccanismo elettronico di sollevamento Lazy Susan, per la pulizia.

Curved plywood structure base with satin brass laminate. Lacquered finish. Lazy Susan Electronic Lifting Mechanism for cleaning, on request.

PAG.
Vol.1 - 286, 287, 288, 289, 291

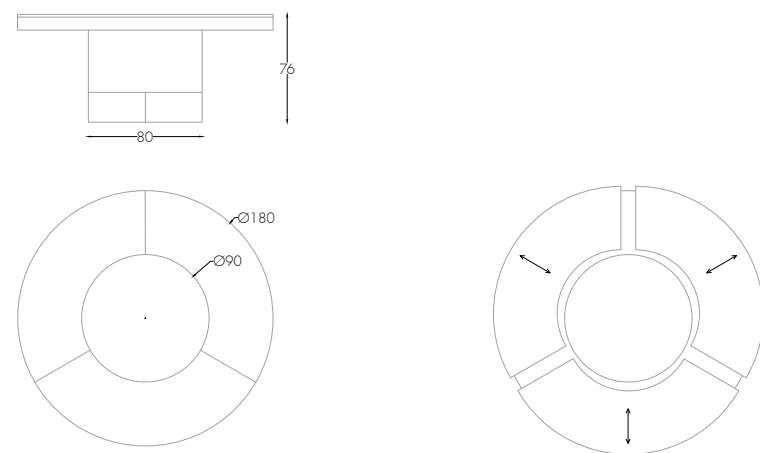

Bolton

TAVOLO - TABLE

00185 - l. 250 x p. 120 x h. 73 cm
00185/G - l. 300 x p. 120 x h. 73 cm

Struttura in legno curvato con trapuntatura cannotté, basamento in metallo finitura titanio. Top in marmo.

Curved wooden structure quilted with cannotté motive, lower part of the base in steel with titanium finish. Marble top.

PAG.
Vol.1 - 340, 341, 342, 343, 345

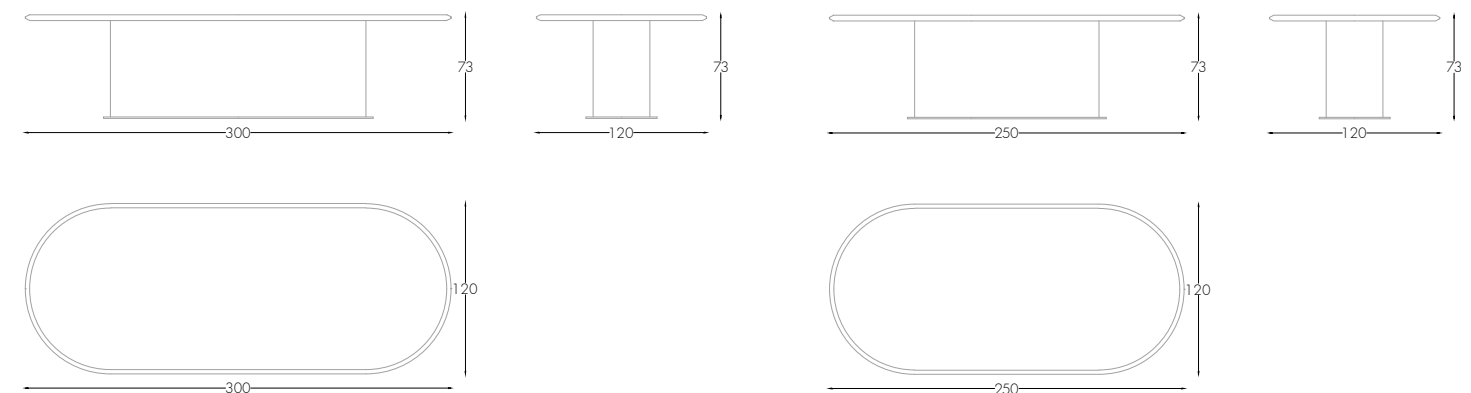
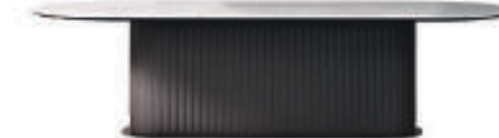

Alfred

TAVOLO - TABLE

00188 - l. 250 x p. 120 x h. 73 cm
00188/G - l. 300 x p. 120 x h. 73 cm

Struttura in legno con trapuntatura a rombi, elementi di fissaggio e decorativi della base in ottone brunito. Top in marmo.

Structure in wood with diamond quilting, fastening and decorative elements of the base in burnished brass. Marble top.

PAG.
Vol.1 - 334, 335, 336, 337, 338

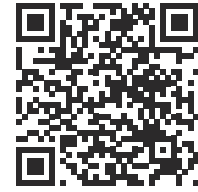
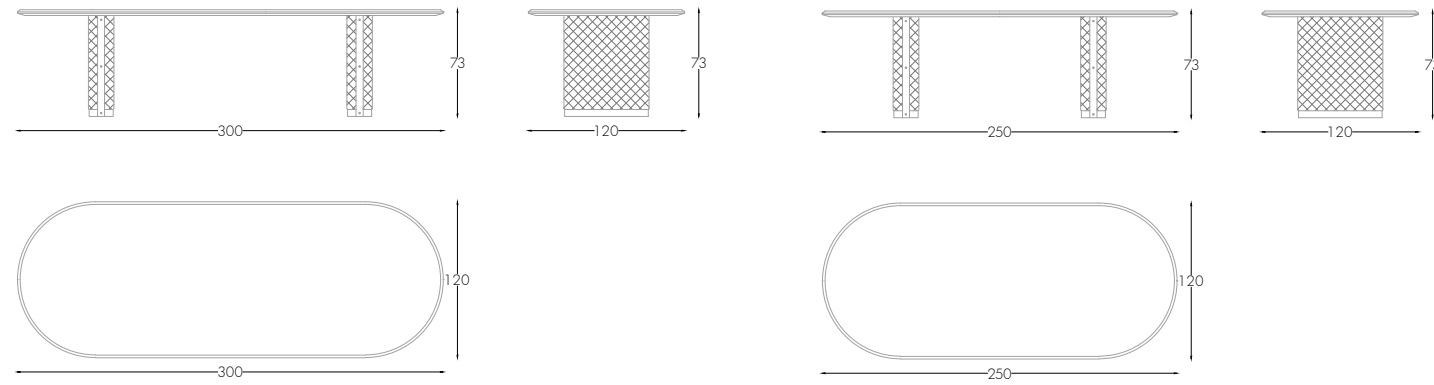

Monogram

TAVOLO - TABLE

00112 - l. 220 x p. 105 x h. 75 cm

Top in multistrati da 6 cm con foderina laccata noce dark, finitura lucida spazzolata. Basamento logo in legno massello con piastra in ottone brunito e bordature con viti a vista.

6 cm lacquered plywood top with dark walnut veneer, brushed glossy finish. Base logo in solid wood with burnished brass plate and steel edges with visible screws.

PAG.
Vol.1 - 372, 373, 374, 375

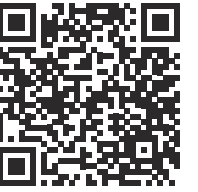
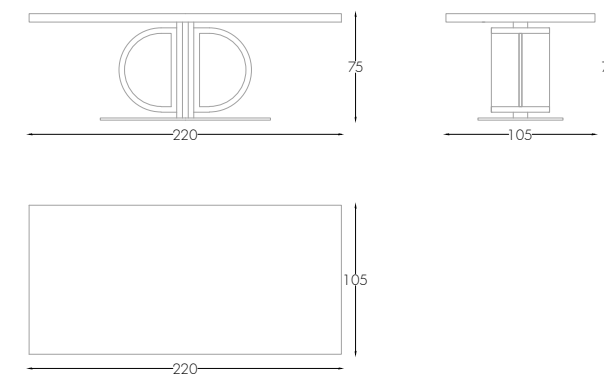

Alfred

TAVOLO - TABLE

00194 - Ø 180 x h. 73 cm

Struttura in legno con trapuntatura a rombi, elementi di fissaggio e decorativi della base in ottone brunito. Top in marmo con Lazy Susan.

Structure in wood with diamond quilting, fastening and decorative elements of the base in burnished brass. Marble top with Lazy Susan.

PAG.
Vol.1 - 328, 329, 330, 331

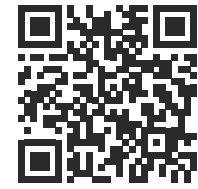
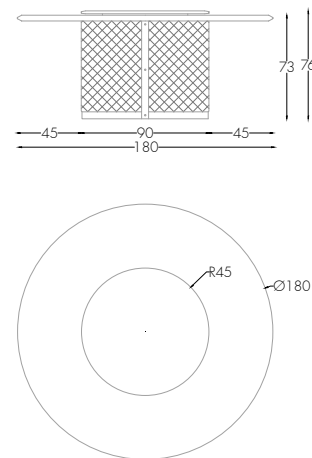

Aston

TAVOLO - TABLE

00048 - l. 250 x p. 110 x h. 73 cm
00048/G - l. 300 x p. 110 x h. 73 cm

Struttura in ottone brunito, top in marmo.

Structure in burnished brass. Marble top.

PAG.
Vol.1 - 382, 383, 384, 385

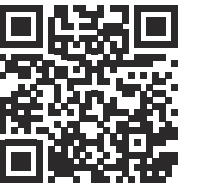
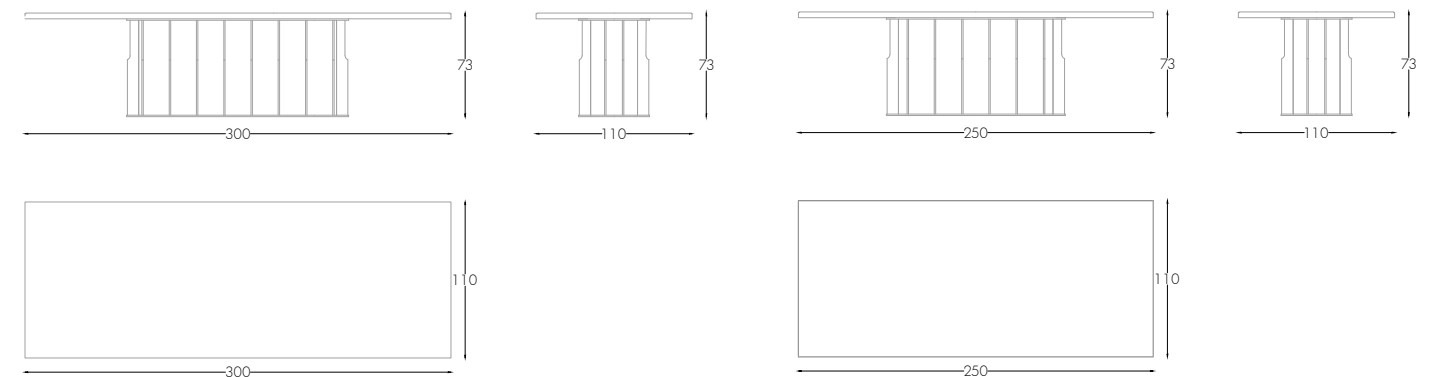

Aston

TAVOLO - TABLE

00047 - Ø 160 x h. 73 cm

Struttura in ottone brunito, top in marmo.
Possibilità di inserimento Lazy Susan.

Structure in burnished brass.
Marble top. Lazy Susan available.

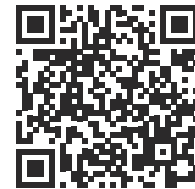
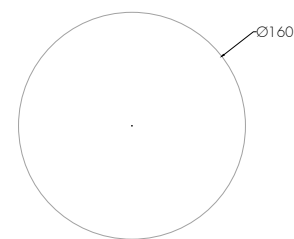
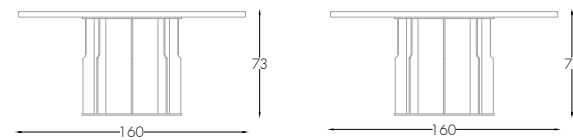

Karma

TAVOLO - TABLE

00148 - l. 160 x p. 160 x h. 75 cm

Top e basamento in multistrati con foderina in noce dark, finitura lucida spazzolata.
Base bordata in lamina finitura ottone brunito.
Particolare lavorazione a trama ondulata sul bordo del top da 10 cm finitura foglia oro patinata lucida o finitura lucida effetto titanio.

Plywood top and base with dark walnut veneer, brushed glossy finish. Base covered with a foil of burnished brass. 10 cm wavy pattern around the edges, glossy coated gold leaf or glossy titanium effect finishing.

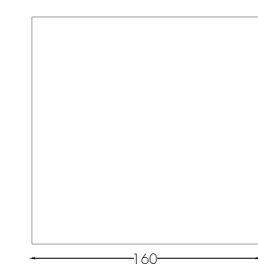
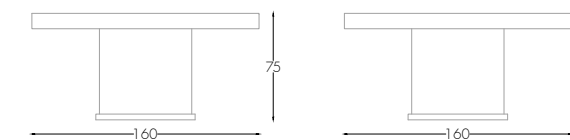

Karma

TAVOLO - TABLE

00148/G - l. 320 x p. 160 x h. 75 cm

Top e basamento in multistrati con foderina in noce dark, finitura lucida spazzolata. Base bordata in lamina finitura ottone brunito.
Particolare lavorazione a trama ondulata sul bordo del top da 10 cm finitura foglia oro patinata lucida o finitura lucida effetto titanio.

Plywood top and base with dark walnut veneer, brushed glossy finish. Base covered with a foil of burnished brass. 10 cm wavy pattern around the edges, glossy coated gold leaf or glossy titanium effect finishing.

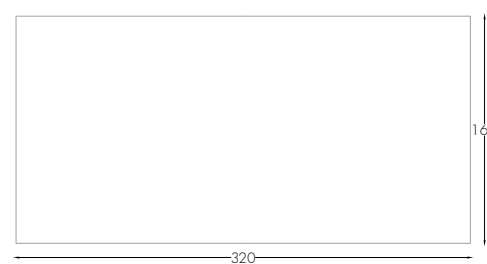
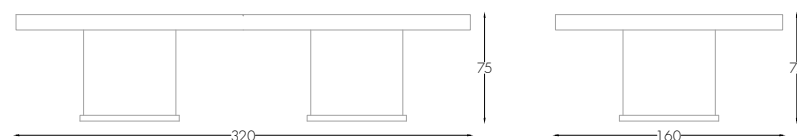

PAG.
Vol.1 - 182, 183, 346, 347, 348



Karma

TAVOLO - TABLE

00113 - Ø 90 x h. 80 cm
00113 - Ø 180 x h. 80 cm

Top e basamento curvato in multistrati con foderina in noce dark, finitura lucida spazzolata. Base bordata in lamina finitura ottone brunito. Particolare lavorazione a trama ondulata sul bordo del top da 10 cm finitura foglia oro patinata lucida o finitura lucida effetto titanio. Top con Lazy Susan.

Curved plywood top and base with dark walnut veneer, brushed glossy finish. Base covered with a foil of burnished brass. 10 cm wavy pattern around the edges, glossy coated gold leaf or glossy titanium effect finishing. Top with Lazy Susan.

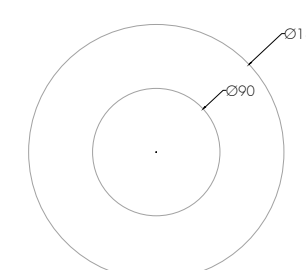
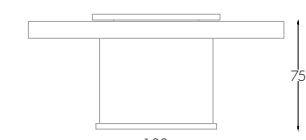

PAG.
Vol.1 - 358, 359, 360, 361, 362

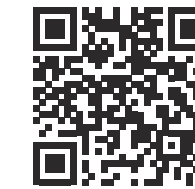

Byron

TAVOLO - TABLE

00063 - l. 250 x p. 110 x h. 75 cm
00063/G - l. 300 x p. 110 x h. 75 cm

Basamento in legno massello di tiglio con trapuntatura cannetté e base in ottone brunito. Top in marmo.

Table in solid linden quilted with cannetté motive and lower part in burnished brass. Marble top.

PAG.
Vol.1 - 389, 392, 393

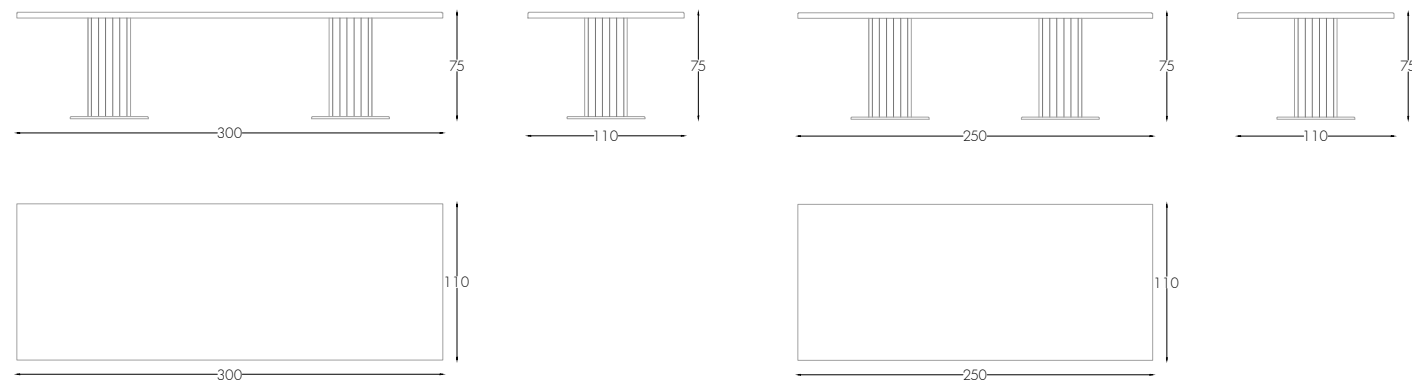

DL02

SEDIA - CHAIR

00233 - l. 55 x p. 58 x h. 80 cm

Struttura imbottita in multistrati curvato, struttura legno in massello di frassino finitura nero opaco a poro aperto. Piedini in ottone satinato.

Curved, padded plywood structure, solid ashwood structure with open-pore opaque black finish. Satin brass feet.

PAG.
Vol.1 - 308, 309, 312, 313

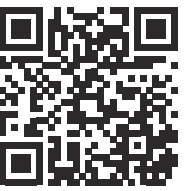
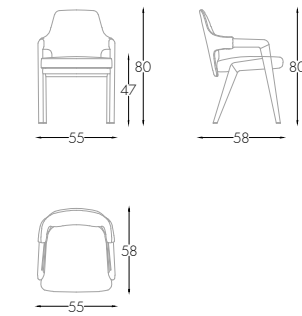

Byron

TAVOLO - TABLE

00055 - Ø 160 x h. 75 cm

Basamento in legno massello di tiglio con trapuntatura cannetté e base in ottone brunito. Top in marmo. Possibilità di inserimento Lazy Susan.

Table in solid linden quilted with cannetté motive and lower part in burnished brass. Marble top. Lazy Susan available.

PAG.
Vol.1 - 396, 397

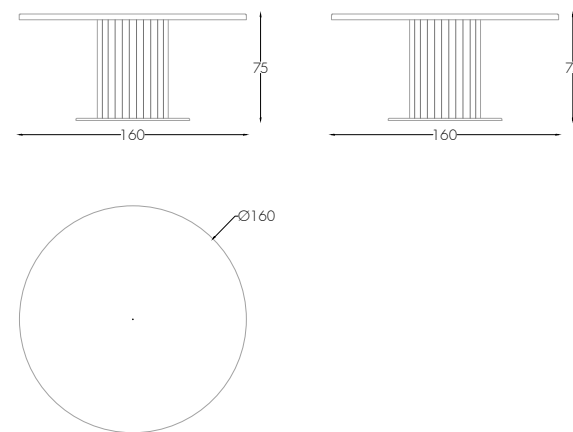

1920

SEDIA - CHAIR

00227 - l. 58 x p. 61 x h. 82 cm

Struttura imbottita in multistrati curvato, basamento in tubolare di ottone calandrato. Dettagli basamento in ottone godronato e finitura ottone satinato.

Curved, padded plywood structure, base in tubular calendared brass. Base details in knurled brass and satin brass finish.

PAG.
Vol.1 - 114, 315, 320, 321

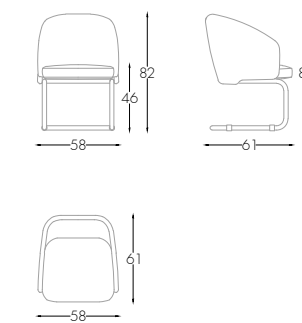

Mya

SEDIA - CHAIR

00230 - l. 55 x p. 53 x h. 80 cm

Struttura imbottita in multistrati curvato con pedini in ottone stinato. Completamente rivestita in tessuto o pelle.

Curved padded plywood structure with satin brass feet. Completely upholstered in leather or fabric.

PAG.

Vol.1 286, 287, 290, 291, 292, 293

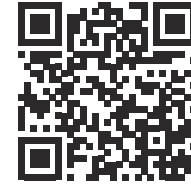
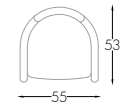
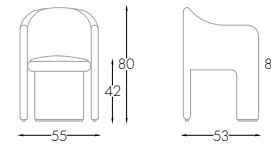

Frida

SEDIA - CHAIR

00197 - l. 54x p. 64 x h. 105 cm

Struttura in legno massello di faggio. Schienale con trapuntatura a rombi e bottoni logati. Gambe completamente rivestite in pelle.

Structure in solid beech wood. Backrest with diamond quilting and buttons with logo. Legs upholstered in leather.

PAG.

Vol.1 - 330, 331, 332, 333

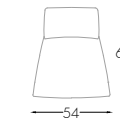
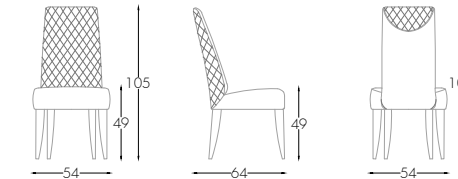

Ade

SEDIA - CHAIR

00236 - l. 55 x p. 54 x h. 86 cm

Struttura imbottita in multistrati curvato, retro schienale rivestito in cuoio, gambe in legno massello di frassino finitura nero opaco a poro aperto, piedini in ottone satinato. Rivestita in tessuto o in pelle.

Curved, padded plywood structure, backrest rear lined in leather, solid ashwood legs with open-pore opaque black finish, satin brass feet. Upholstered in leather or fabric.

PAG.

Vol.1 - 68, 69, 301, 304, 305, 307

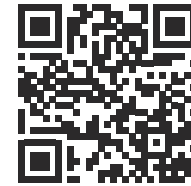
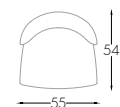
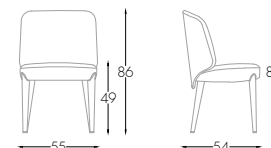

Sofia

SEDIA - CHAIR

00061 - l. 52 x p. 60 x h. 90 cm

Struttura in legno massello di faggio. Schienale con trapuntatura a rombi. Gambe completamente rivestite in pelle.

Structure in solid beech wood. Backrest with diamond quilting. Legs upholstered in leather.

PAG.

Vol.1 - 394, 395

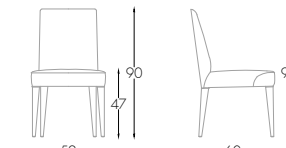

Julia

SEDIA - CHAIR

00164 - l. 57 x p. 53 x h. 90 cm

Struttura in legno massello di faggio e multistrati, gambe laccate lucide spazzolate colore fumo. Rivestimento in tessuto o pelle.

Structure in plywood solid beech wood, brushed lacquered glossy legs with "fumo" finish. Upholstery in fabric or leather.

PAG.
Vol.1 - 342, 343, 344

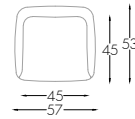
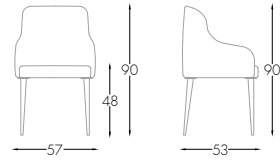

Nicole

SEDIA - CHAIR

00165 - l. 65 x p. 62 x h. 94 cm

Struttura in legno massello di faggio, profili e gambe laccati lucidi spazzolati colore fumo. Rivestimento in tessuto o pelle.

Structure in solid beech wood, brushed lacquered glossy contour and legs with "fumo" finish. Upholstery in fabric or leather.

PAG.
Vol.1 - 182, 183, 187, 346, 347
Vol.2 - 10, 11

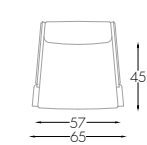
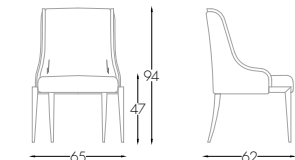

Liz

SEDIA - CHAIR

00013 - l. 50 x p. 60 x h. 98 cm

Struttura in legno massello di faggio, gambe laccate lucide spazzolate colore fumo. Rivestimento in tessuto o pelle.

Structure in solid beech wood, brushed lacquered glossy legs with "fumo" finish. Upholstery in fabric or leather.

PAG.
Vol.1 - 358, 359, 362

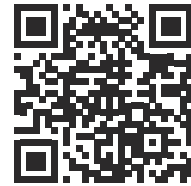
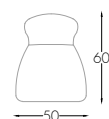
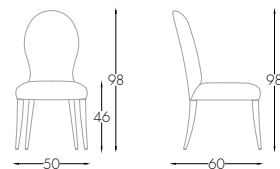

Bacco

SEDIA - CHAIR

00163 - l. 60 x p. 58 x h. 84 cm

Struttura in multistrati, con trapuntatura a rombi e bottoni logati. Rivestimento interno in tessuto o pelle.

Plywood structure, diamond quilting and buttons with logo. Upholstery in fabric or leather.

PAG.
Vol.1 - 208, 209, 334, 335, 336, 340, 342

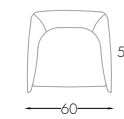
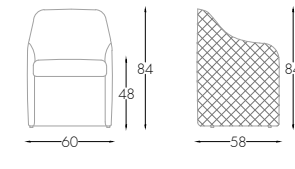

Isabel

SEDIA - CHAIR

00066 - l. 60 x p. 55 x h. 90 cm

Struttura in multistrati, con trapuntatura cannetté.
Base in ottone brunito.
Rivestimento in tessuto o pelle.

Plywood structure with quilted with cannetté motive.
Base in burnished brass.
Upholstery in fabric or leather.

PAG.
Vol.1 - 348, 349, 396, 397

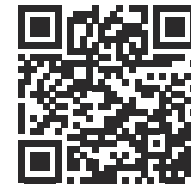
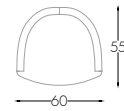
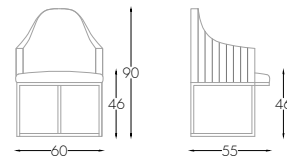

Hanna

SEDIA - CHAIR

00064 - l. 58 x p. 54 x h. 95 cm

Struttura in legno massello di faggio. Interno con trapuntatura a rombi. Gambe completamente rivestite in pelle.

Structure in solid beech wood. Internal part with diamond quilting. Legs upholstered in leather.

PAG.
Vol.1 - 382, 383, 384, 385, 386, 387

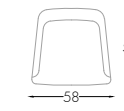
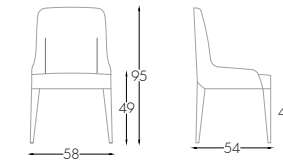

Vivien

SEDIA - CHAIR

00060 - l. 54 x p. 64 x h. 105 cm

Struttura in legno massello di faggio. Schienale con trapuntatura a rombi. Gambe laccate lucide spazzolate colore fumo. Rivestimento in tessuto o pelle.

Structure in solid beech wood. Backrest with diamond quilting. Brushed lacquered glossy legs with "fumo" finish. Upholstery in fabric or leather.

PAG.
Vol.1 - 372, 373

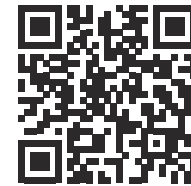
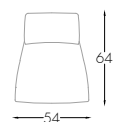
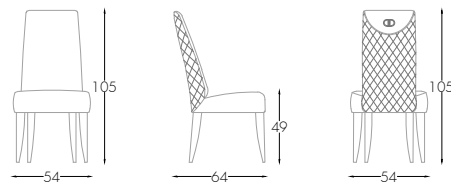

Dany

SGABELLO - STOOL

00114 - l. 52 x p. 56 x h. 68/103 cm

Struttura in legno massello di faggio. Schienale con trapuntatura a rombi. Gambe laccate lucide spazzolate colore fumo e traversi in ottone brunito. Rivestimento in tessuto o pelle.

Structure in solid beech wood. Backrest with diamond quilting. Brushed lacquered glossy legs with "fumo" finish and horizontal elements in burnished brass. Upholstery in fabric or leather.

PAG.
Vol.1 - 408, 409

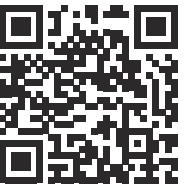
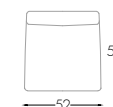
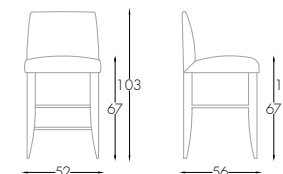

Sirio

SGABELLO - STOOL

00115 - Ø 55 x h. 90 cm

Struttura in legno massello di faggio. Bordo con trapuntatura cannettè. Stelo in ottone brunito. Rivestimento in tessuto o pelle.

Structure in solid beech wood. Side quilted with cannettè motive. Base in burnished brass. Upholstery in fabric or leather.

PAG.
Vol.1 - 400, 401, 406

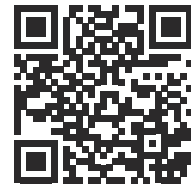
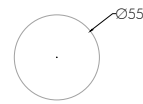
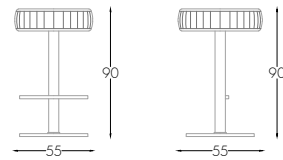

Hilary

SEDIA - CHAIR

00193 - l. 57 x p. 67 x h. 88 cm

Struttura in multistrati curvato. Imbottita con gomme di varie densità, seduta con cinghie elastiche da 6 cm. Basamento con ruote in gomma autofrenanti. Rivestimento in tessuto o pelle.

Curved plywood structure. Padded with multi-density rubber, seat with 6 cm elastic belts. Base with rubber self-braking casters. Upholstery in fabric or leather.

PAG.
Vol.2 - 20, 21

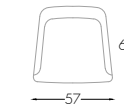
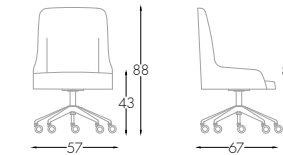

Bill

POLTRONA - ARMCHAIR

00025 - l. 65 x p. 65 x h. 118 cm

Struttura in multistrati curvato, esterno con foderina noce dark finitura lucida spazzolata. Imbottita con gomme di varie densità, seduta con cinghie elastiche da 6 cm. Basamento con ruote in gomma autofrenanti. Rivestimento in tessuto o pelle.

Curved plywood structure, in dark walnut veneer, lacquered brushed glossy finish. Padded with multi-density rubber, seat with 6 cm elastic belts. Base with rubber self-braking casters. Upholstery in fabric or leather.

PAG.
Vol.2 - 16, 20, 21

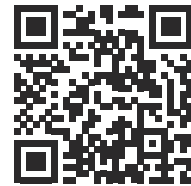
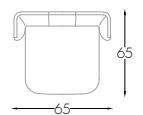
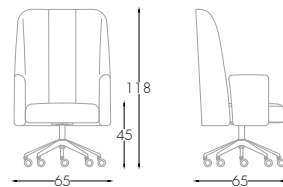

Aimo

SCRITTOIO - DESK

00268 - l. 160 x p. 70 x h. 76 cm

Struttura in profilato di ottone satinato, blocco basamento in multistrati laccato fumo lucido, top in multistrati da 4 cm con foderina frassino 10/10 finitura laccata nero opaco a poro aperto.

Structure in satin brass profile, base block in shiny smoke-lacquered plywood, 4 cm plywood top in ashwood 10/10 veneer, open-pore opaque black lacquered finish.

PAG.
Vol.2 - 5, 6, 7, 8, 9

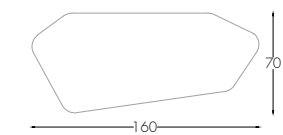
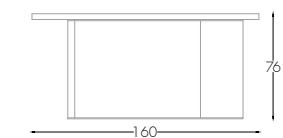

Monica

SCRIVANIA - DESK

00021 - l. 200 x p. 100 x h. 75 cm

Struttura in multistrati curvato rivestito in pelle con cuciture a vista, top multistrati con foderina noce dark finitura lucida spazzolata. Cassettiera tappezzata in tessuto, base e sottopiano rivestiti con lamina in ottone brunito.

Curved plywood structure upholstered in leather with visible seams. Plywood top with dark walnut veneer, lacquered brass finish. Chest of drawers with fabric lining, base and lower shelf covered in burnished brass foil.

PAG.
Vol.2 - 16, 18, 20, 21

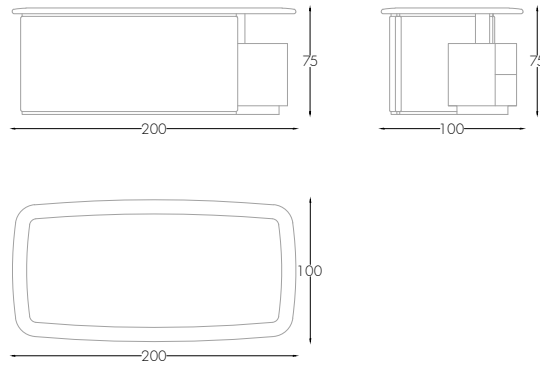

Dante

SCRITTOIO - DESK

00147 - l. 130 x p. 55x h. 88 cm

Struttura in multistrati con foderina noce dark e basamento in noce massello, finitura lucida spazzolata. Cassetti grandi tappezzati in tessuto con guide soft metalliche. Maniglie in ottone brunito.

Plywood structure with dark walnut veneer and solid walnut base, brushed glossy finish. Large drawers upholstered in fabric with soft metal runners. Handles in burnished brass.

PAG.
Vol. 1 - 187
Vol.2 - 10, 11, 12, 13

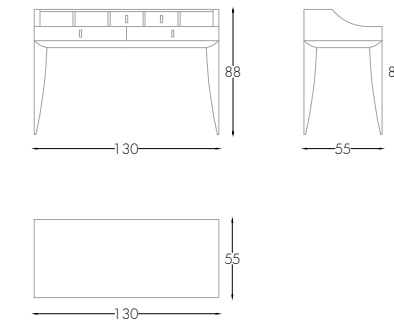

Jack

SCRITTOIO - DESK

00037/S - l. 130 x p. 50 x h. 72 cm

Struttura in multistrati, un cassetto tappezzato in tessuto con guide soft metalliche. Frontale e cassetto con trapuntatura cannetté. Basamento e maniglie in ottone brunito e top in marmo.

Plywood structure, fabric lined drawers with soft metal runners. Drawer fronts quilted with cannetté motive. Base and handles in burnished brass. Marble top.

PAG.
Vol.2 - 14, 15

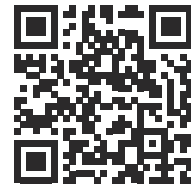
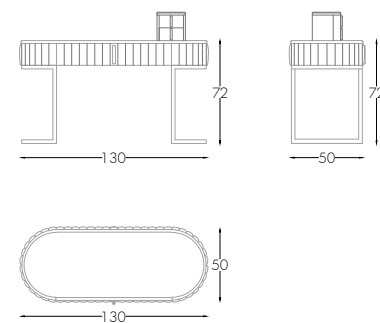

Vermont

LIBRERIA - BOOKCASE

00020 - l. 360 x p. 55 x h. 224 cm

Struttura in multistrati con foderina noce dark, assemblaggio con tecnica folding. Ante finitura lucida spazzolata e vetro naturale, fumè o bronzo. Cerniere ante con chiusura soft. Maniglie in ottone brunito e pelle.

Plywood structure with dark walnut veneer, assembled using folding technique. Brushed glossy finish doors with natural smoked or bronze mirror, soft-closing hinges and brass handles with burnished brass finish and leather.

PAG.
Vol.2 - 16, 20, 21

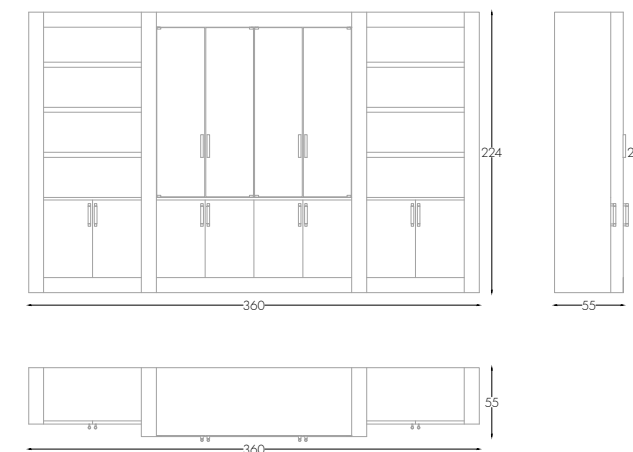

Flag

LETTO - BED

00264 - l. 200 x p. 222 x h. 115 cm

Struttura in multistrati, imbottita con gomme di varie densità, fissaggi con squadre in acciaio verniciate. Elementi di sostegno testiera e pediera in profilato di ottone satinato. Predisposto per rete in appoggio. Rivestimento in pelle o in tessuto.

Plywood structure, padded with multi-density rubber, square varnished steel fixtures. Headrest and feet support elements in satin brass profile. Ready for mattress base. Upholstered in leather or fabric.



PAG.

Vol.2 - 40, 41, 43, 44, 45

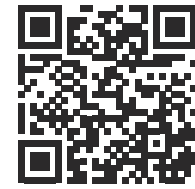
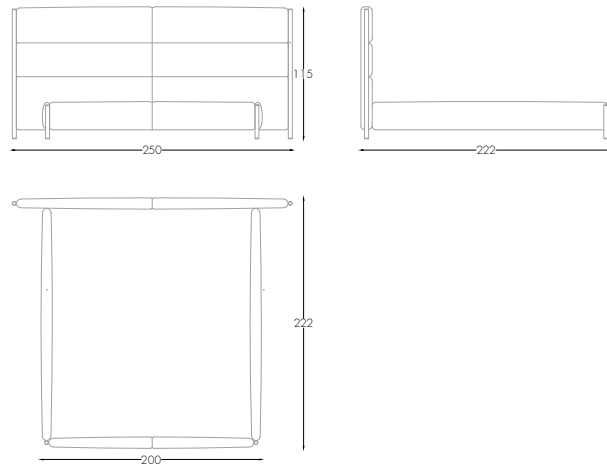

Renko

LETTO - BED

00223 - l. 200 x p. 222 x h. 92 cm

Struttura in multistrati, imbottita con gomme di varie densità, fissaggi con squadre in acciaio verniciate. Gambe in profilato di ottone satinato. Predisposto per rete in appoggio. Rivestimento in pelle o tessuto.

Plywood structure, padded with multi-density rubber, square varnished steel fixtures. Legs in satin brass profile. Ready for mattress base. Upholstered in leather or fabric.



PAG.

Vol.2 - 24, 25, 26, 27, 28, 29, 31

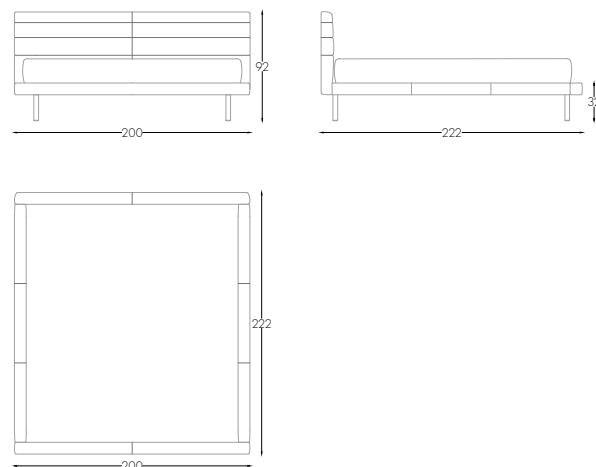

Alfred

LETTO - BED

00209 - l. 200 x p. 222 x h. 160 cm

Struttura in multistrati, imbottita con gomme di varie densità, fissaggi con squadre in acciaio verniciate. Testata con trapuntatura a rombi, inserti in ottone brunito e bottoni logati. Predisposto per rete in appoggio. Rivestimento in tessuto o pelle.

Plywood structure, padded with multi-density rubbers, steel painted bracket fasteners. Headboard with diamond quilting, burnished brass decorative inserts and buttons with logo. Ready to support bedbase. Upholstery in fabric or leather.



PAG.

Vol.2 - 48, 49, 50, 51, 53

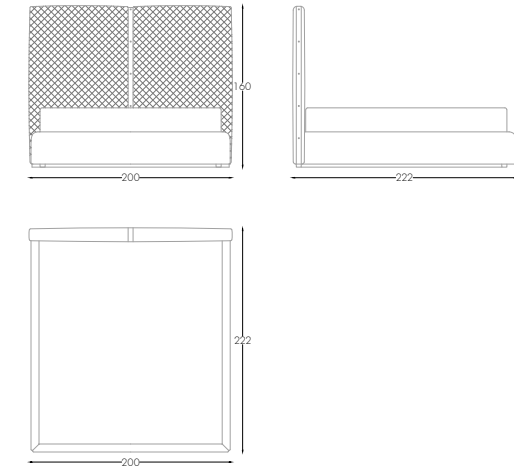

Ziggy

LETTO - BED

00168/S - l. 200 x 222 x h. 155 cm

Struttura in multistrati, imbottita con gomme di varie densità, fissaggi con squadre in acciaio verniciate. Testata con lavorazione a doghe orizzontali, inserti in ottone brunito. Predisposto per rete in appoggio. Rivestimento in tessuto o pelle.

Plywood structure, padded with multi-density rubbers, steel painted bracket fasteners. Headboard with burnished brass decorative inserts. Ready to support bedbase. Upholstery in fabric or leather.



PAG.

Vol.2 - 70, 71

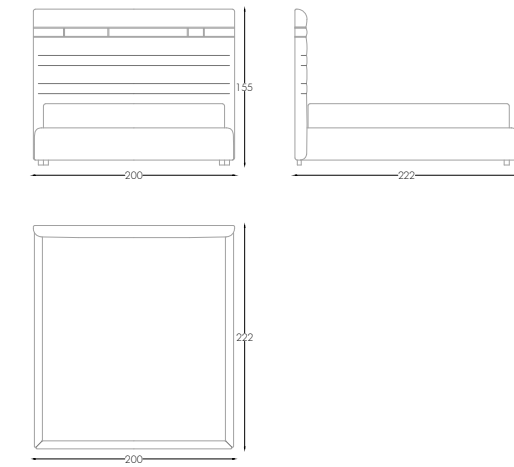

Ziggy

LETTO - BED

00168 - l. 380 x 222 x h. 155 cm

Struttura in multistrati, imbottita con gomme di varie densità, fissaggi con squadre in acciaio verniciate. Testata con lavorazione a doghe orizzontali, inserti in finitura ottone brunito. Predisposto per rete in appoggio. Rivestimento in tessuto o pelle.

Plywood structure, padded with multi-density rubbers, steel painted bracket fasteners. Headboard with burnished brass decorative inserts. Ready to support bedbase. Upholstery in fabric or leather.

PAG.
Vol.2 - 66, 67, 68, 69

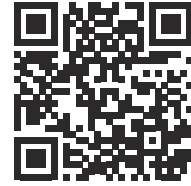
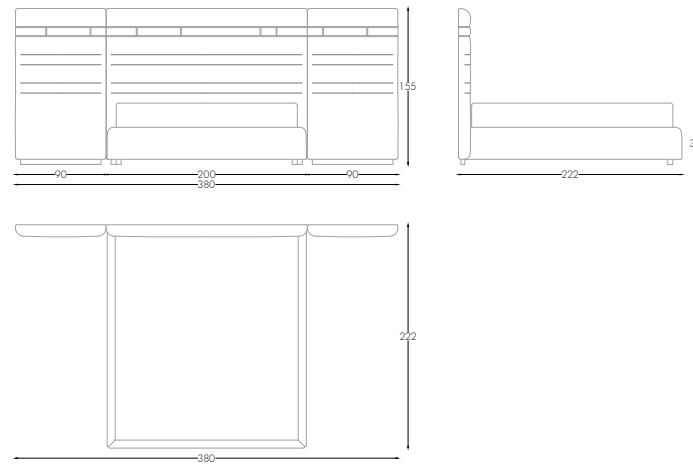

Florence

LETTO - BED

00169 - l. 220 x 222 x h. 160 cm

Struttura in multistrati, imbottita con gomme di varie densità, fissaggi con squadre in acciaio verniciate. Testata con lavorazione a doghe orizzontali, inserti in ottone brunito. Predisposto per rete in appoggio. Rivestimento in tessuto o pelle.

Plywood structure, padded with multi-density rubbers, steel painted bracket fasteners. Headboard with burnished brass decorative inserts. Ready to support bedbase. Upholstery in fabric or leather.

PAG.
Vol.2 - 58, 59, 60, 65

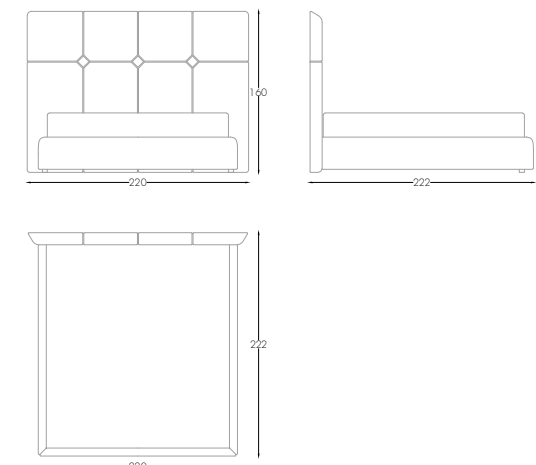

Julius

LETTO - BED

00101 - l. 200 x 230 x h. 105 cm
00101/H - l. 200 x 230 x h. 120 cm

Struttura in multistrati, imbottita con gomme di varie densità, fissaggi con squadre in acciaio verniciate. Testata con inserti trapuntati, ring con trapuntatura a rombi e bottoni logati. Predisposto per rete in appoggio. Rivestimento in tessuto o pelle.

Plywood structure, padded with multi-density rubbers, steel painted bracket fasteners. Headboard with quilted inserts, bedframe with diamond quilting and buttons with logo. Ready to support bedbase. Upholstery in fabric or leather.

PAG.
Vol.2 72, 73, 74, 76

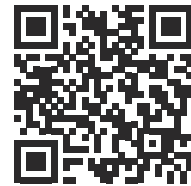
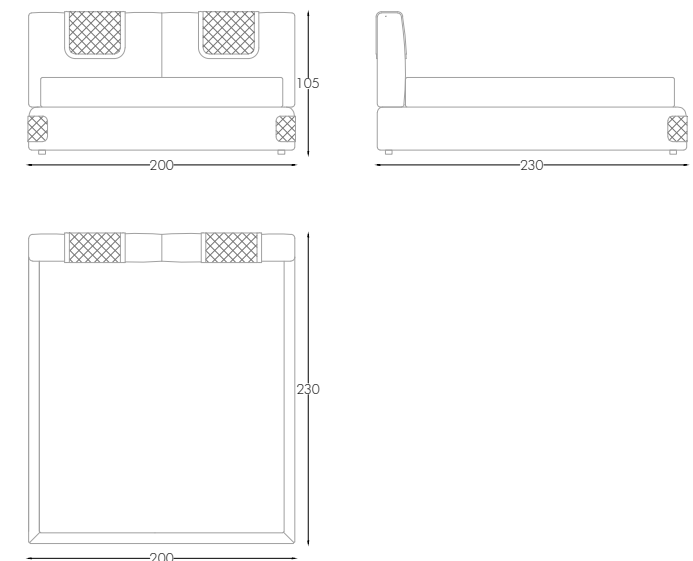

Manhattan

LETTO - BED

00062 - l. 220 x p. 225 x h. 130 cm

Struttura in multistrati, imbottita con gomme di varie densità, fissaggi con squadre in acciaio verniciate. Testata imbottita e rivestimento posteriore con foderina noce dark finitura lucida spazzolata. Predisposto per rete in appoggio. Rivestimento in tessuto o pelle.

Plywood structure, padded with multi-density rubbers, steel painted bracket fasteners. Padded headboard, externally covered with dark walnut veneer and brushed glossy finish. Ready to support bedbase. Upholstery in fabric or leather.

PAG.
Vol.2 - 90, 91, 92, 93

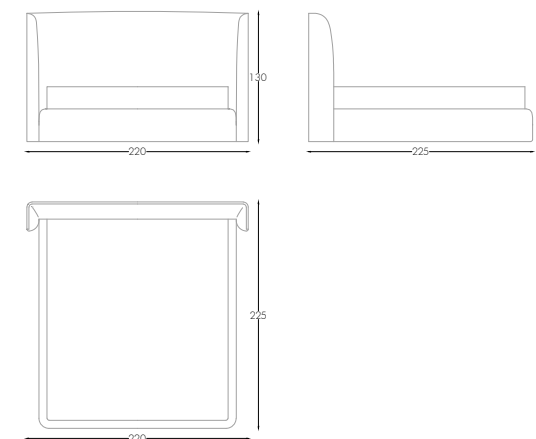

Ulisse

LETTO - BED

00030 - l. 400 x p. 230 x h. 130 cm

Struttura in multistrati, imbottita con gomme di varie densità, fissaggi con squadre in acciaio verniciate. Testata con lavorazione a rombi. Predisposto per rete in appoggio. Rivestimento in tessuto o pelle.

Plywood structure, padded with multi-density rubbers, steel painted bracket fasteners. Headboard with diamond quilting. Ready to support bedbase. Upholstery in fabric or leather.



PAG.
Vol.2 - 116, 117, 119

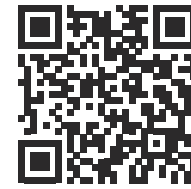
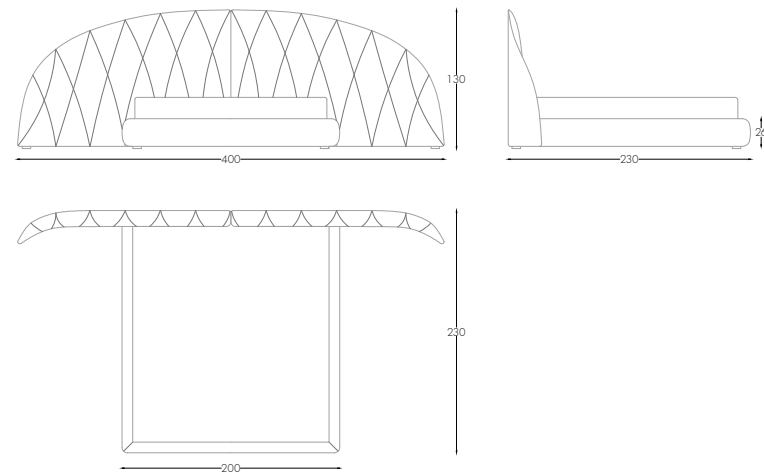

Memento

LETTO - BED

00012 - l. 240 x p. 244 x h. 154 cm

Struttura in multistrati, imbottita con gomme di varie densità, fissaggi con squadre in acciaio verniciate. Testata con lavorazione capitonné. Predisposto per rete in appoggio. Rivestimento in tessuto o pelle.

Plywood structure, padded with multi-density rubbers, steel painted bracket fasteners. Header quilted with capitonné motive. Ready to support bedbase. Upholstery in fabric or leather.



PAG.
Vol.2 - 104, 105, 106

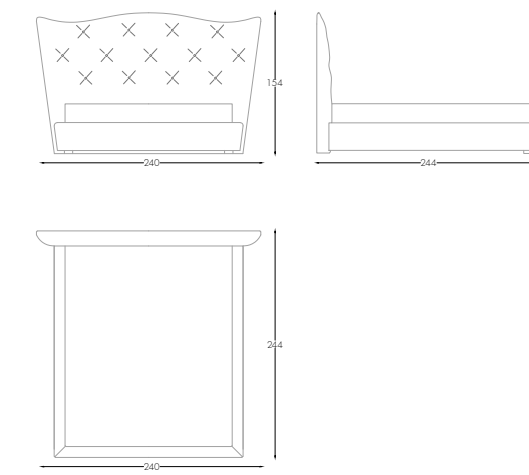

Lord

LETTO - BED

00022 - l. 194 x p. 216 x h. 160 cm

Struttura in multistrati, imbottita con gomme di varie densità, fissaggi con squadre in acciaio verniciate. Testata con lavorazione a doghe verticali. Predisposto per rete in appoggio. Rivestimento in tessuto o pelle.

Plywood structure, padded with multi-density rubbers, steel painted bracket fasteners. Headboard with vertical stitching. Ready to support bedbase. Upholstery in fabric or leather.



PAG.
Vol.2 - 96, 97, 98, 99

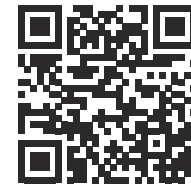
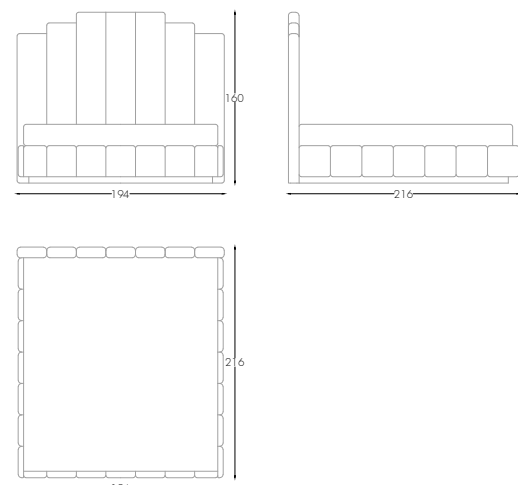

Voyage

LETTO - BED

00032 - l. 193 x p. 215 x h. 30 cm

Struttura in multistrati, imbottita con gomme di varie densità, fissaggi con squadre in acciaio verniciate. Giroletto con trapuntatura cannetté. Predisposto per rete in appoggio. Rivestimento in tessuto o pelle. In abbinamento alla boiserie Voyage.

Plywood structure, padded with multi-density rubbers, steel painted bracket fasteners. Bedbase quilted with cannetté motive. Ready to support bedbase. Upholstery in fabric or leather. You can complete with boiserie Voyage.



PAG.
Vol.2 - 110, 111, 113

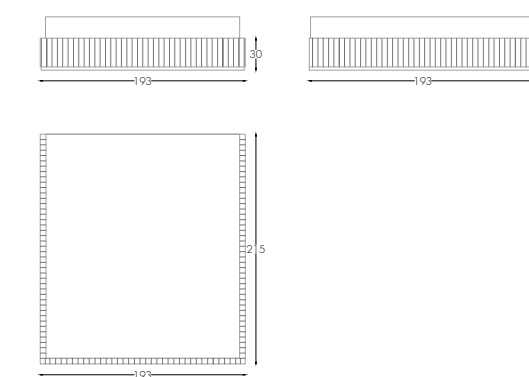

Pablo

LETTO - BED

00183 - l. 200 x p. 222 x h. 160 cm

Struttura in multistrati, imbottita con gomme di varie densità, fissaggi con squadre in acciaio verniciate. Testata con lavorazione a doghe verticali, inserti in ottone brunito. Predisposto per rete in appoggio. Rivestimento in tessuto o pelle.

Plywood structure, padded with multi-density rubbers, steel painted bracket fasteners. Headboard with vertical design and burnished brass decorative inserts. Ready to support bedbase. Upholstery in fabric or leather.



PAG.

Vol.2 - 80, 81, 83, 88, 89

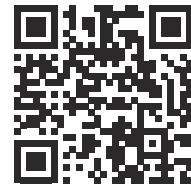
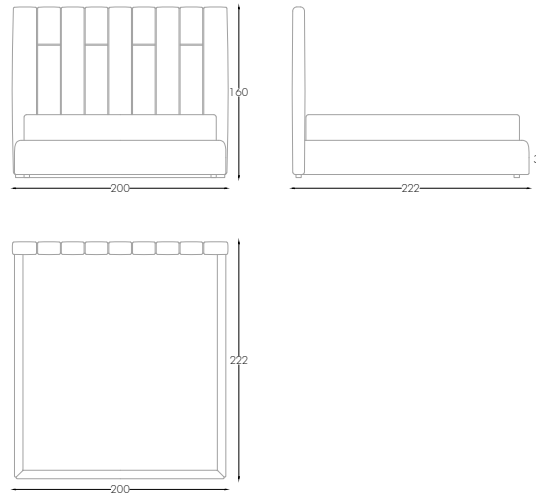

Rimmel

TOILETTE - DRESSING TABLE

00037/E - l. 130 x p. 50 x h. 72 cm

Struttura in multistrati, un cassetto tappezzato in tessuto con guide soft metalliche. Frontale e cassetto con trapuntatura cannetté. Basamento e maniglie in ottone brunito e top in marmo.

Plywood structure with fabric lined drawer and soft metal runners. Quilted with cannetté motive. Base and handles in burnished brass. Marble top.



PAG.

Vol.2 - 115

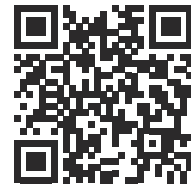
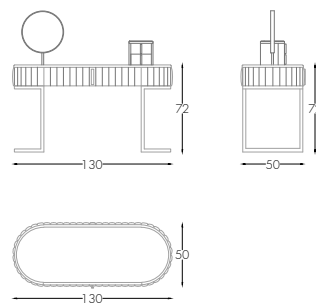

Lips

POUFF - POUFFE

00038 - Ø 46 x h. 40 cm

Struttura in multistrati, rivestimento con gomme di varie densità, strato superiore in air soft, ricoperto da una soffice falda di piuma d'oca su tutta la superficie. Trapuntatura cannetté. Base con lamina in ottone brunito. Rivestimento in tessuto o pelle.

Plywood structure, covered with multi-density rubbers, upper layer in air soft, covered with a soft layer of goose down over the entire surface. Quilted with cannetté motive. Base with burnished brass foil. Upholstery in fabric or leathers.

PAG.

Vol.1 - 264

Vol.2 - 115, 169

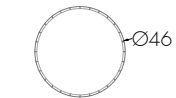
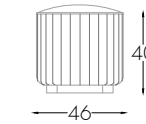

Milano

PANCA - BENCH

00167 - l. 150 x p. 60 x h. 36 cm

Struttura in multistrati, rivestimento con gomme di varie densità, strato superiore in air soft, ricoperto da una soffice falda di piuma d'oca su tutta la superficie. Base in ottone brunito. Rivestimento in tessuto o pelle.

Plywood structure, covered with multi-density rubbers, upper layer in air soft, covered with a soft layer of goose down over the entire surface. Base in burnished brass. Upholstery in fabric or leathers.

PAG.

Vol.2 - 8, 89

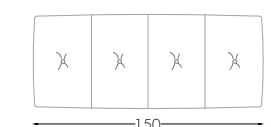
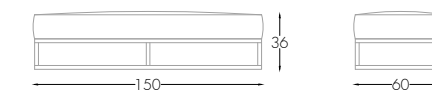

Dante

PANCA - BENCH

00166 - l. 150 x p. 60 x h. 40 cm

Struttura in multistrati, rivestimento con gomme di varie densità, strato superiore in air soft, ricoperto da una soffice falda di piuma d'oca su tutta la superficie. Base e piedi in noce dark finitura lucida spazzolata. Rivestimento in tessuto o pelle.

Plywood structure, covered with multi-density rubbers, upper layer in air soft, covered with a soft layer of goose down over the entire surface. Base in dark walnut with brushed glossy finish. Upholstery in fabric or leather.

PAG.
Vol.2 - 78, 79, 80, 81

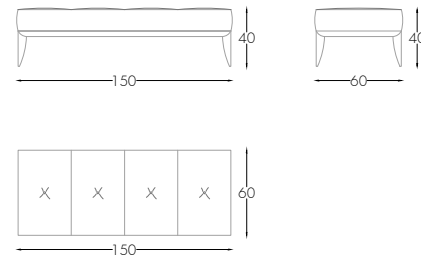

Loft

COMÒ DOUBLE 6 CASSETTI - DOUBLE DRESSER
6 DRAWERS

00142 - l. 180 x p. 60 x h. 80 cm

Struttura in multistrati e top in legno finitura laccata lucida spazzolata. Cassetti tappezzati in tessuto con guide soft metalliche. Basamento e maniglie in ottone brunito.

Plywood structure with wooden top, lacquered brushed glossy finish. Fabric lined drawers with soft metal runners. Base and handles in burnished brass.

PAG.
Vol.2 - 84

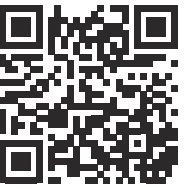
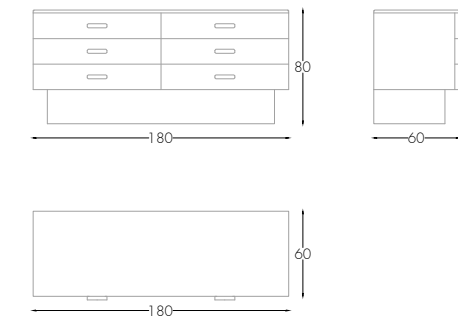

Bubble

PANCHETTA - BENCH SEAT

00050 - l. 130 x p. 50 x h. 46 cm

Struttura in multistrati, rivestimento con gomme di varie densità, strato superiore in air soft, ricoperto da una soffice falda di piuma d'oca su tutta la superficie. Trapuntatura cannetté. Base in ottone brunito. Rivestimento in tessuto o pelle.

Plywood structure, covered with multi-density rubbers, upper layer in air soft, covered with a soft layer of goose down over the entire surface. Quilted with cannetté motive. Base in burnished brass. Upholstery in fabric or leathers.

PAG.
Vol.2 - 113

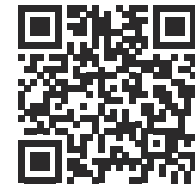
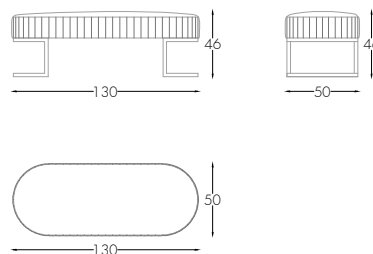

Loft

COMÒ 2 CASSETTI - DRESSER 2 DRAWERS

00141 - l. 150 x p. 60 x h. 74 cm

Struttura in multistrati e top in legno finitura laccata lucida spazzolata. Cassetti tappezzati in tessuto con guide soft metalliche. Basamento e maniglie in ottone brunito.

Plywood structure with wooden top, lacquered brushed glossy finish. Fabric lined drawers with soft metal runners. Base and handles in burnished brass.

PAG.
Vol.2 - 86, 87

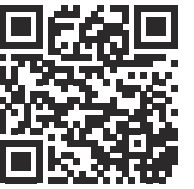
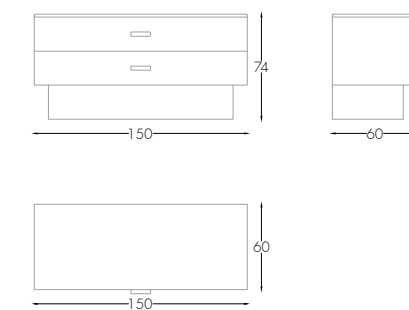

Loft

COMODINO 3 CASSETTI - NIGHTSTAND 3 DRAWERS

00143 - l. 80 x p. 50 x h. 67 cm

Struttura in multistrati e top in legno finitura laccata lucida spazzolata. Cassetti tappezzati in tessuto con guide soft metalliche. Basamento e maniglie in ottone brunito.

Plywood structure with wooden top, lacquered brushed glossy finish. Fabric lined drawers with soft metal runners. Base and handles in burnished brass.

PAG.
Vol.2 - 80, 83, 88, 89

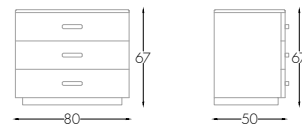

Dante

COMÒ 2 CASSETTI - DRESSER 2 DRAWERS

00131/P - l. 150 x 60 x h. 88 cm

Struttura in multistrati con foderina noce dark finitura lucida spazzolata. Cassetti tappezzati in tessuto con guide soft metalliche. Maniglie in ottone brunito e top in marmo.

Plywood structure with dark walnut veneer, brushed glossy finish. Fabric lined drawers with soft metal runners. Handles in burnished brass. Marble top.

PAG.
Vol.2 - 64, 65

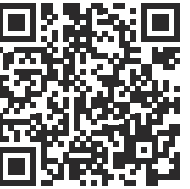
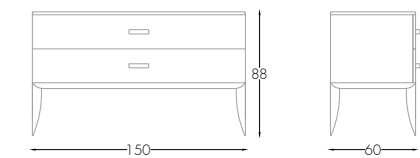

Dante

COMÒ DOUBLE 6 CASSETTI - DOUBLE DRESSER 6 DRAWERS

00131 - l. 180 x 60 x h. 93 cm

Struttura in multistrati con foderina noce dark finitura lucida spazzolata. Cassetti tappezzati in tessuto con guide soft metalliche. Maniglie in ottone brunito e top in marmo.

Plywood structure with dark walnut veneer, brushed glossy finish. Fabric lined drawers with soft metal runners. Handles in burnished brass. Marble top.

PAG.
Vol.2 - 58, 62, 63

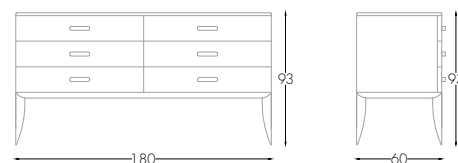

Dante

COMODINO - NIGHTSTAND

00132 - l. 80 x p. 50 x h. 48 cm

Struttura in multistrati con foderina noce dark finitura lucida spazzolata. Cassetti tappezzati in tessuto con guide soft metalliche. Maniglie in ottone brunito e top in marmo.

Plywood structure with dark walnut veneer, brushed glossy finish. Fabric lined drawers with soft metal runners. Handles in burnished brass. Marble top.

PAG.
Vol.2 - 59, 60, 61, 65

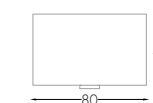
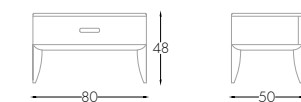

Alfred

COMÒ DOUBLE 6 CASSETTI - DOUBLE DRESSER
6 DRAWERS

00207 - l. 160 X p. 50 X h. 79 cm

Struttura in multistrati, con trapuntatura a rombi, inserti in finitura ottone brunito e bottoni logati. Cassetti tappezzati in tessuto con guide soft metalliche. Basamento e maniglie in ottone brunito e top in marmo.

Plywood structure with diamond quilting, burnished brass finish inserts and buttons with logo. Fabric lined drawers with soft metal runners. Base and handles in burnished brass. Marble top.

PAG.
Vol.2 - 54, 55, 56, 57, 123, 124

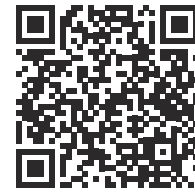
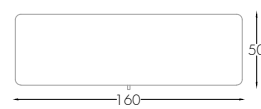
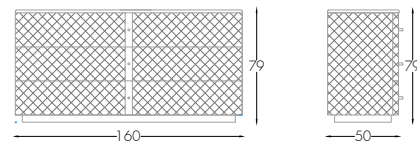

Mayfair

COMODINO 2 CASSETTI - NIGHTSTAND 2
DRAWERS

00039 - l. 70 x p. 48 x h. 50 cm

Struttura in multistrati curvato con foderina noce dark finitura lucida spazzolata. Cassetti tappezzati in tessuto con guide soft metalliche. Basamento e maniglie in ottone brunito e top in marmo o pelle.

Curved plywood structure with dark walnut veneer, brushed glossy finish. Fabric lined drawers with soft metal runners. Base and handles in burnished brass. Marble or leather top.

PAG.
Vol.2 - 116, 117

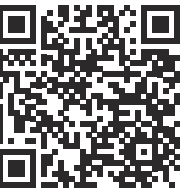
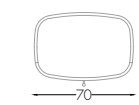
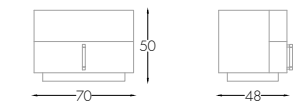

Alfred

COMODINO 3 CASSETTI - NIGHTSTAND 3
DRAWERS

00208 - l. 60 x p. 50 x h. 61 cm

Struttura in multistrati, con trapuntatura a rombi, inserti in finitura ottone brunito e bottoni logati. Cassetti tappezzati in tessuto con guide soft metalliche. Basamento e maniglie in ottone brunito e top in marmo.

Plywood structure with diamond quilting, burnished brass finish inserts and buttons with logo. Fabric lined drawers with soft metal runners. Base and handles in burnished brass. Marble top.

PAG.
Vol.2 - 48, 49, 52, 53

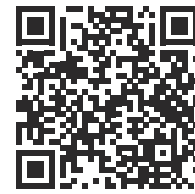
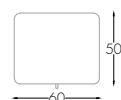
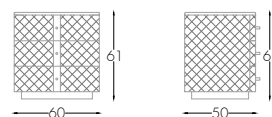

Mayfair

COMODINO 3 CASSETTI - NIGHTSTAND 3
DRAWERS

00040 - l. 70 x p. 48 x h. 66 cm

Struttura in multistrati curvato con foderina noce dark finitura lucida spazzolata. Cassetti tappezzati in tessuto con guide soft metalliche. Basamento e maniglie in ottone brunito e top in marmo o pelle.

Curved plywood structure with dark walnut veneer, brushed glossy finish. Fabric lined drawers with soft metal runners. Base and handles in burnished brass. Marble or leather top.

PAG.
Vol.2 - 90, 93, 94, 119

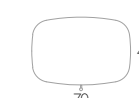
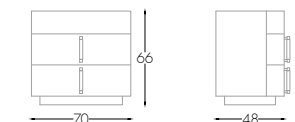

Milano

COMÒ - DRESSER

00043 - l. 150 x p. 60 x h. 70 cm

Struttura in multistrati con foderina noce dark finitura lucida spazzolata. Cassetti tappezzati in tessuto con guide soft metalliche. Basamento e maniglie in ottone brunito e top in marmo.

Plywood structure with dark walnut veneer, brushed glossy finish. Fabric lined drawers with soft metal runners. Base and handles in burnished brass. Marble top.

PAG.
Vol.2 - 109

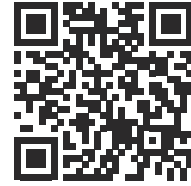
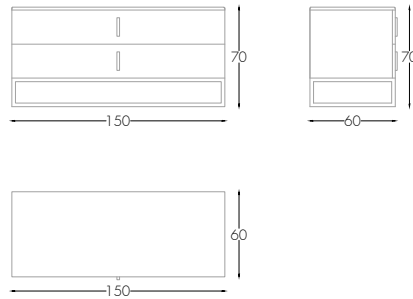

Double c

COMÒ - DRESSER

00033 - l. 150 x p. 55 x h. 70 cm

Struttura in multistrati curvato con foderina noce dark finitura lucida spazzolata. Cassetti tappezzati in tessuto con guide soft metalliche. Maniglie in ottone brunito e top in marmo o pelle.

Curved plywood structure with dark walnut veneer, brushed glossy finish. Fabric lined drawers with soft metal runners. Handles in burnished brass. Marble or leather top.

PAG.
Vol.2 - 103

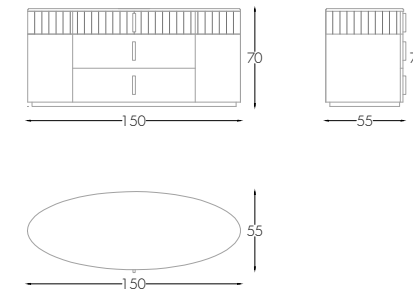

Milano

COMODINO - NIGHTSTAND

00044 - l. 65 x p. 45 x h. 45 cm

Struttura in multistrati con foderina noce dark finitura lucida spazzolata. Cassetti tappezzati in tessuto con guide soft metalliche. Basamento e maniglie in ottone brunito e top in marmo.

Plywood structure with dark walnut veneer, brushed glossy finish. Fabric lined drawers with soft metal runners. Base and handles in burnished brass. Marble top.

PAG.
Vol.2 - 106

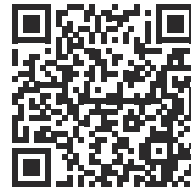
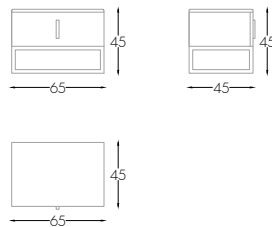

Double c

SETTIMANALE - TALLBOY

00028 - l. 65 x p. 45 x h. 135 cm

Struttura in multistrati curvato con foderina noce dark finitura lucida spazzolata. Cassetti tappezzati in tessuto con guide soft metalliche. Maniglie in ottone brunito e top in marmo o pelle.

Curved plywood structure with dark walnut veneer, brushed glossy finish. Fabric lined drawers with soft metal runners. Handles in burnished brass. Marble or leather top.

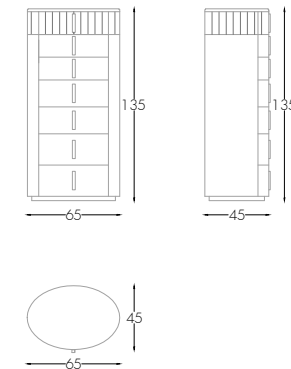

Double c

COMODINO - NIGHTSTAND

00034 - l. 65 x p. 45 x h. 55 cm

Struttura in multistrati curvato con foderina noce dark finitura lucida spazzolata. Cassetto superiore con trapuntatura cannetté. Cassetti tappezzati in tessuto con guide soft metalliche. Maniglie in ottone brunito e top in marmo.

Curved plywood structure with dark walnut veneer, brushed glossy finish. Upper drawer quilted with cannetté motive. Fabric lined drawers with soft metal runners. Handles in burnished brass. Marble or leather top.



PAG.
Vol.2 - 40, 41, 96, 97, 100, 104, 105, 113

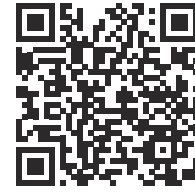
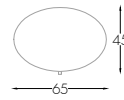
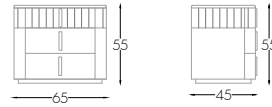

Hamilton

COMODINO - NIGHTSTAND

00024 - l. 65 x p. 45 x h. 45 cm

Struttura in multistrati con foderina noce dark interno ed esterno. Finitura lucida spazzolata. Cassetto con trapuntatura cannetté. Maniglia in ottone brunito.

Plywood structure with inside and outside dark walnut veneer. Bushed glossy finish. Drawer quilted with cannetté motive. Handle in burnished brass.



PAG.
Vol.2 - 23, 24, 28, 31, 32, 33, 110

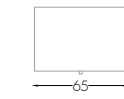
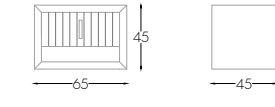

Hamilton

COMÒ - DRESSER

00023 - l. 160 x p. 60 x h. 80 cm

Struttura in multistrati con foderina noce dark interno ed esterno. Finitura lucida spazzolata. Cassetti con trapuntatura cannetté. Maniglie in ottone brunito.

Plywood structure with inside and outside dark walnut veneer. Bushed glossy finish. Drawers quilted with cannetté motive. Handles in burnished brass.



PAG.
Vol.2 - 34, 35, 36, 37

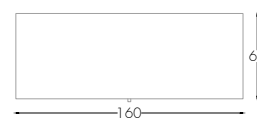
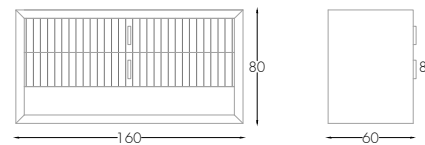

Hamilton

PANCA - BENCH

00045 - l. 140 x p. 45 x h. 40 cm

Struttura in multistrati con foderina noce dark interno ed esterno. Finitura lucida spazzolata. Cassetto con trapuntatura cannetté. Maniglia in ottone brunito.

Plywood structure with inside and outside dark walnut veneer. Bushed glossy finish. Drawer quilted with cannetté motive. Handles in burnished brass.



PAG.
Vol.2 - 111

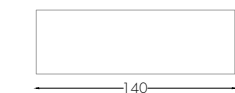
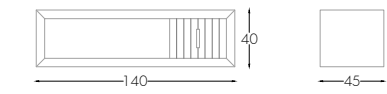

Bytheway

- 00015 - CABINA ARMADIO - WALK-IN CLOSET
- 00126 - PORTA CAMICIE - SHIRT RACK
- 00124 - PORTA PANTALONI - TROUSERS RACK
- 00125 - CESTELLI ESTRAIBILI - PULL OUT BASKETS
- 00127 - GRUCCIA - HANGER

Struttura in multistrati con foderina noce dark finitura lucida spazzolata o opaca. Zoccolo con lamina finitura ottone brunito. Cassetti con guide soft metalliche e trapuntatura canneté. Possibilità di inserimento accessori e faretti led.

Plywood structure with dark walnut veneer, brushed glossy finish. Plinth in burnished brass finish foil. Drawers with soft metal runners, quilted with canneté motive. It is possible to insert accessories and led spotlights. Boiserie in grey mirtle with brass details.



PAG.
Vol.2 - 81, 128, 129, 130, 131, 132, 135, 136

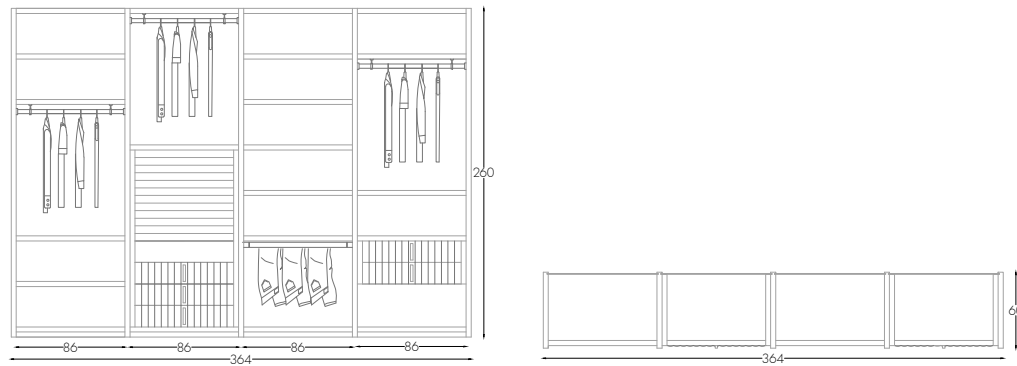

Nautilus

- 00215 - CABINA ARMADIO - WALK-IN CLOSET

Struttura in multistrati con foderina noce dark finitura lucida spazzolata o opaca. Composto da cremagliere liberamente posizionabili e supporti logati finitura ottone brunito. Cassetti con guide soft metalliche. Possibilità di inserimento accessori e faretti led.

Plywood structure with dark walnut veneer and brushed glossy or matt finish. Gear racks with free positions and burnished brass finish supports with logo. Soft metal runners for drawers. It is possible to insert accessories and LED spotlights.

PAG.
Vol.2 - 124, 125, 126, 127

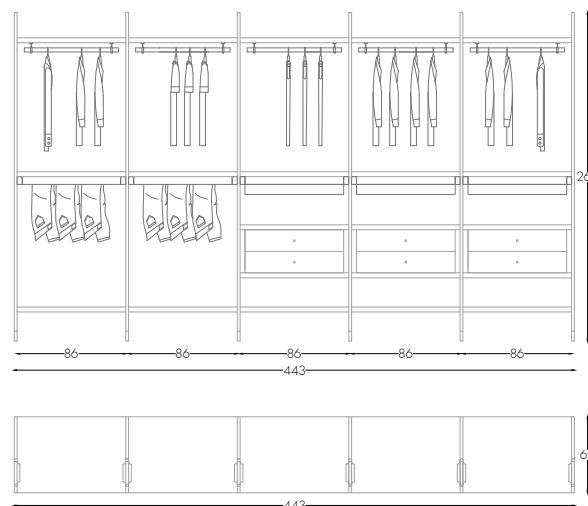

Nautilus

- NAUTILUS
- 00216 - CABINA ARMADIO CON SCHIENALE RIVESTITO
- WALK-IN CLOSET WITH COVERED PANEL

Struttura in multistrati con foderina noce dark finitura lucida spazzolata o opaca. Composto da cremagliere liberamente posizionabili e supporti logati finitura ottone brunito. Cassetti con guide soft metalliche. Possibilità di inserimento accessori e faretti led.

Plywood structure with dark walnut veneer and brushed glossy or matt finish. Gear racks with free positions and burnished brass finish supports with logo. Soft metal runners for drawers. It is possible to insert accessories and LED spotlights.

PAG.
Vol.2 - 122, 123

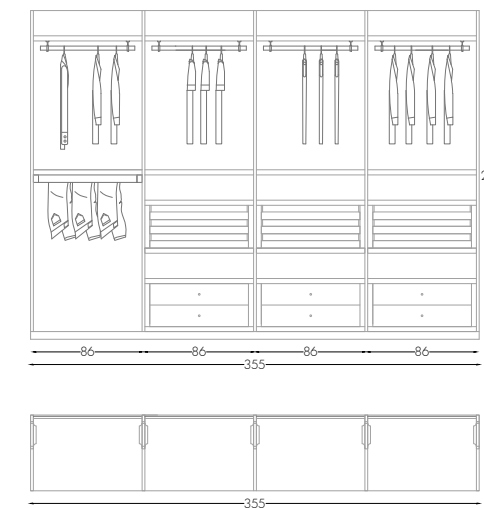

Opium

SPECCHIERA - MIRROR

00153 - l. 40 x h. 40 cm

Cornice in noce massello, finitura laccata lucida spazzolata colore ebony. Specchio naturale.

Solid walnut frame, lacquered brushed glossy "ebony" finish. Natural mirror.

PAG.

Vol.1 - 182, 183, 346, 347
Vol.2 - 218, 219

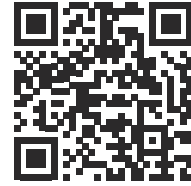
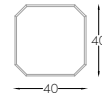

Origami

SPECCHIERA - MIRROR

00153/B - l. 40 x h. 80 cm

Cornice in noce massello, finitura laccata lucida spazzolata colore ebony. Specchio naturale.

Solid walnut frame, lacquered brushed glossy "ebony" finish. Natural mirror.

PAG.

Vol.1 - 182, 183, 346, 347
Vol.2 - 218, 219

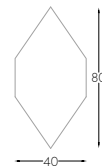

Gipsy

SPECCHIERA - MIRROR

00153/C - l. 40 x h. 80 cm

Cornice in noce massello, finitura laccata lucida spazzolata colore ebony. Specchio naturale.

Solid walnut frame, lacquered brushed glossy "ebony" finish. Natural mirror.

PAG.

Vol.1 - 182, 183, 346, 347
Vol.2 - 218, 219

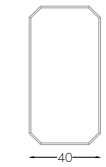

Avenue

SPECCHIERA - MIRROR

00153/D - l. 40 x h. 80 cm

Cornice in noce massello, finitura laccata lucida spazzolata colore ebony. Specchio naturale.

Solid walnut frame, lacquered brushed glossy "ebony" finish. Natural mirror.

PAG.

Vol.1 - 182, 183, 346, 347
Vol.2 - 218, 219



Balalaika

SPECCHIERA - MIRROR

00153/A - l. 30 x h. 40 cm

Cornice in noce massello, finitura laccata lucida spazzolata colore ebony. Specchio naturale.

Solid walnut frame, lacquered brushed glossy "ebony" finish. Natural mirror.

PAG.
Vol.1 - 182, 183, 346, 347
Vol.2 - 218, 219



DL120

SPECCHIO - MIRROR

00280 - l. 90 x p. 2 x h. 180 cm

Pannello in legno finitura nero opaco, specchio naturale e fumé.

Wooden veneer with opaque black finish, natural and smoke-grey mirror.

PAG.
Vol.1 - 36, 37
Vol.2 - 214, 215

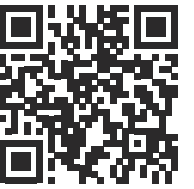
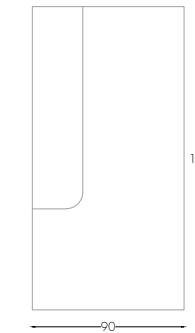

Decò

SPECCHIO - MIRROR

00085 - l. 70 x p. 2 x h. 70 cm

Telaio in ottone brunito. Specchio naturale molato.

Frame in burnished brass. Natural ground mirror.

PAG.
Vol.1 - 213, 392
Vol.2 - 226, 227

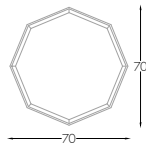

DL118

DL118
SPECCHIO - MIRROR

00279 - l. 80 x p. 2 x h. 110 cm

Pannello in legno finitura nero opaco, specchio naturale e fumé.

Wooden veneer with opaque black finish, natural and smoke-grey mirror.

PAG.
Vol.1 - 92
Vol.2 - 212, 213

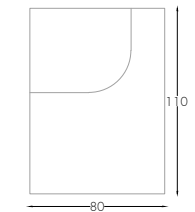

DL116

SPECCHIO - MIRROR

00278 - l. 90 x p. 2 x h. 90 cm

Pannello in legno finitura nero opaco, specchio naturale e fumé.

Wooden veneer with opaque black finish, natural and smoke-grey mirror.

PAG.
Vol.2 - 210, 211

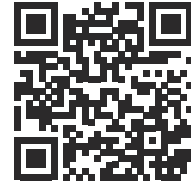
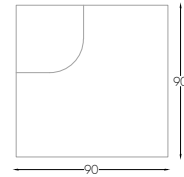

Dante

SPECCHIO - MIRROR

00136 - l. 160 x p. 5 x h. 160 cm

Cornice in noce massello finitura ottone lucido spazzolato. Specchio naturale.

Solid walnut wood frame, brushed glossy brass finish. Natural mirror.

PAG.
Vol.2 - 63, 222, 223

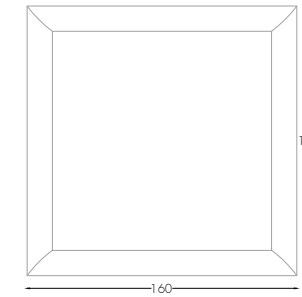

Regent

SPECCHIO - MIRROR

00097/G - l. 100 x h. 200 cm
00097 - l. 77 x h. 136 cm

Specchio naturale molato con incisione a rombi.
Pannello posteriore in legno laccato nero opaco.

Ground clear mirror with rhombus effect engraving.
Back panel in black lacquered matt wood.

PAG.
Vol.2 - 78, 220, 221

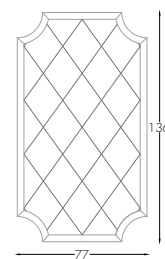
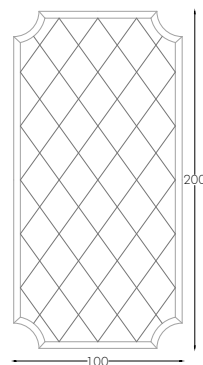

Prisma

SPECCHIO - MIRROR

00281 - l. 90 x p. 3 x h. 192 cm

Cornice in legno con lavorazione a prismi, finitura ottone lucido spazzolato e specchio naturale.

Wooden frame with prisms, glossy brass finish and natural mirror.

PAG.
Vol.1 - 122
Vol.2 - 216, 217

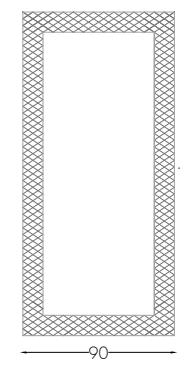

Tao

SPECCHIO - MIRROR

00035 - l. 100 x h. 200 cm

Cornice in legno massello di acero con lavorazione cannetté, finitura laccata lucida spazzolata o opaca. Specchio naturale.

Frame in solid maple with Cannetté motive, lacquered brushed glossy or matt finish. Natural mirror.

PAG.
Vol.2 - 232, 233

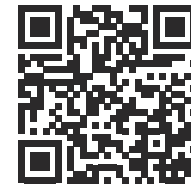
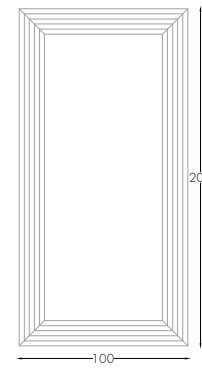

Jubilee

SPECCHIO - MIRROR

00075 - l. 120 x h. 240 cm

Cornice in legno, con lavorazione a trama ondulata finitura foglia oro patinata lucida o finitura lucida effetto titanio. Specchio naturale.

Wood frame with wavy texture. Glossy coated gold leaf or glossy titanium effect finishing. Natural mirror.

PAG.
Vol.2 - 84, 230, 231

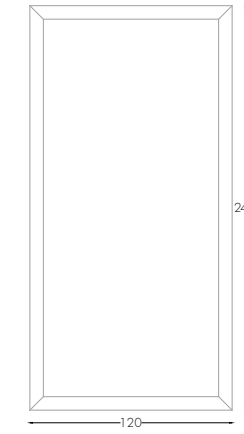

Hudson

SPECCHIO - MIRROR

00102 - l. 120 x h. 240 cm

Cornice in legno rivestita in pelle o nabuk. Specchio naturale.

Wooden frame covered in leather or nubuck leather. Natural mirror.

PAG.
Vol.2 - 224, 225

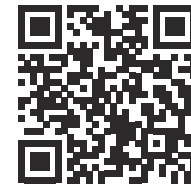
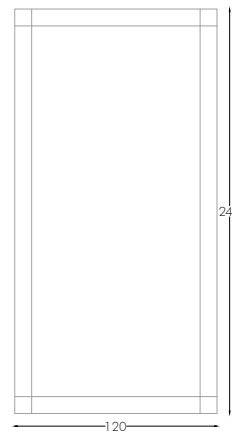

Fahrenheit

SPECCHIO - MIRROR

00105 - l. 120 x h. 240 cm

Cornice rivestita in specchio fumè con logo. Specchio naturale. Pannello posteriore in legno laccato nero opaco.

Smoked mirror frame with logo in the 4 corners. Natural mirror. Back panel in black lacquered matt wood.

PAG.
Vol.2 - 228, 229

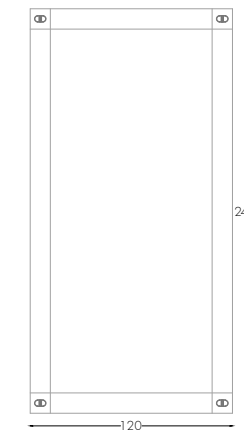

Caccia

LAMPADA DA TAVOLO - TABLE LAMP

00273 - l. 50 x p. 20 x h. 60 cm

Struttura in ottone satinato, dettaglio in marmo Calacatta oro, predisposta per nr. 2 lampadine E27. Paralume in raso nero.

Satin brass structure, detail in Calacatta gold marble, ready for 2 E27 bulbs. Lampshade in black satin.

PAG.
Vol.1 - 77, 83
Vol.2 - 144, 145

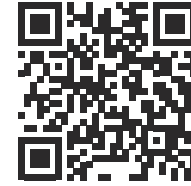
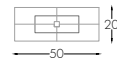
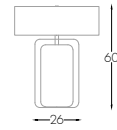

Caccia

LAMPADA DA TAVOLO - TABLE LAMP

00275 - l. 50 x p. 20 x h. 60 cm

Struttura in ottone satinato, dettaglio in marmo Calacatta oro, predisposta per nr. 2 lampadine E27. Paralume in raso nero.

Satin brass structure, detail in Calacatta gold marble, ready for 2 E27 bulbs. Lampshade in black satin.

PAG.
Vol.2 - 144

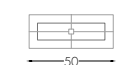
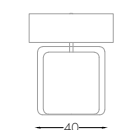

Caccia

LAMPADA DA TAVOLO - TABLE LAMP

00274 - l. 50 x p. 20 x h. 60 cm

Struttura in ottone satinato, dettaglio in marmo Calacatta oro, predisposta per nr. 2 lampadine E27. Paralume in raso nero.

Satin brass structure, detail in Calacatta gold marble, ready for 2 E27 bulbs. Lampshade in black satin.

PAG.
Vol.2 - 37, 144

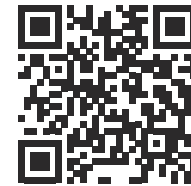
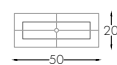
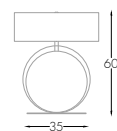

Ettore

LAMPADA DA TAVOLO - TABLE LAMP

00312 - Ø 40 x h. 60 cm

Struttura in ottone satinato, dettaglio in marmo Calacatta oro, predisposta per nr. 2 lampadine E27. Paralume in raso nero.

Satin brass structure, detail in Calacatta gold marble, ready for 2 E27 bulbs. Lampshade in black satin.

PAG.
Vol.2 - 142

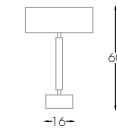

Ettore

LAMPADA DA TAVOLO - TABLE LAMP

00287 - l. 45 x p. 25 x h. 60 cm

Struttura in ottone satinato, dettaglio in marmo Calacatta oro, predisposta per nr. 2 lampadine E27. Paralume in raso nero.

Satin brass structure, detail in Calacatta gold marble, ready for 2 E27 bulbs. Lampshade in black satin.

PAG.
Vol.2 - 24, 25, 142, 143

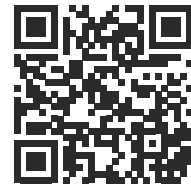
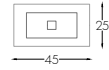
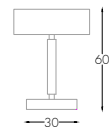

Meccano

LAMPADA DA TAVOLO - TABLE LAMP

00276 - Ø 36 x h. 62 cm

Struttura in ottone satinato con dettaglio in marmo Calacatta oro e led integrato.

Satin brass structure with detail in Calacatta gold marble and integrated led.

PAG.
Vol.2 - 6, 7, 140, 141

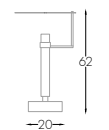

Rigaround

PIANTANA - FLOOR LAMP

00314 - l. 40 x p. 40 x h. 170 cm

Stelo in legno laccato lucido con lavorazione cannette. Predisposta per lampadina E27. Paralume in raso nero.

Glossy lacquered wood stem with ribbed quilt upholstery. Ready for E27 bulb. Lampshade in black satin.

PAG.
Vol.1 - 290, 291
Vol.2 - 146, 147

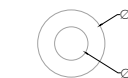
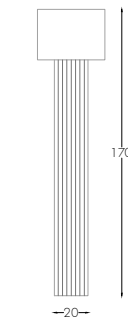

Rigaround

LAMPADA DA TAVOLO - TABLE LAMP

00315 - l. 40 x p. 40 x h. 65 cm

Stelo in legno laccato lucido con lavorazione cannette. Predisposta per lampadina E27. Paralume in raso nero.

Glossy lacquered wood stem with ribbed quilt upholstery. Ready for E27 bulb. Lampshade in black satin.

PAG.
Vol.2 - 40, 146

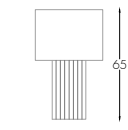

Riga

PIANTANA - FLOOR LAMP

00316 - l. 60 x p. 40 x h. 170 cm

Stelo in legno laccato lucido con lavorazione cannette. Predisposta per lampadina E27. Paralume in raso nero.

Glossy lacquered wood stem with ribbed quilt upholstery. Ready for E27 bulb. Lampshade in black satin.

PAG.
Vol.2 - 148

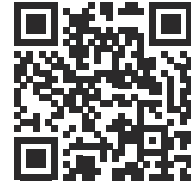
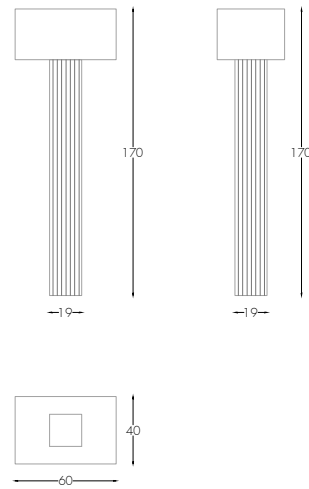

Arona

PIANTANA - FLOOR LAMP

00256 - l. 43 x p. 43 x h. 152 cm

Struttura in profilato di ottone satinato, pianetto in vetro fumé, predisposta per lampadina E27. Paralume in raso nero.

Structure in satin brass profile, smoke-grey glass inset, ready for E27 bulb. Lampshade in black satin.

PAG.
Vol.1 - 108, 300
Vol.2 - 150, 151

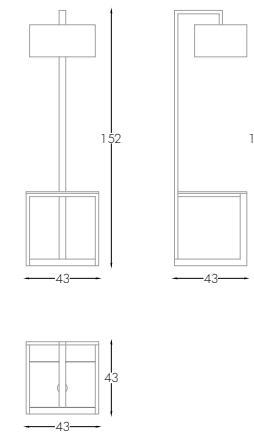

Riga

LAMPADA DA TAVOLO - TABLE LAMP

00317 - l. 40 x p. 25 x h. 60 cm

Stelo in legno laccato lucido con lavorazione cannette. Predisposta per lampadina E27. Paralume in raso nero.

Glossy lacquered wood stem with ribbed quilt upholstery. Ready for E27 bulb. Lampshade in black satin.

PAG.
Vol.1 - 68
Vol.2 - 148, 149

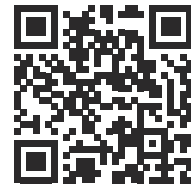
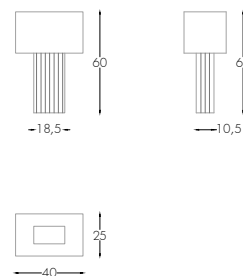

Queen

QUEEN PIANTANA - FLOOR LAMP

00272 - Ø 40 x h. 156 cm

Struttura regolabile in altezza in ottone satinato, predisposto per lampadina E27. Paralume in raso nero.

Height adjustable structure in satin brass, ready for E27 bulb. Lampshade in black satin.

PAG.
Vol.1 - 35
Vol.2 - 41, 46, 152, 153

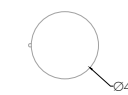
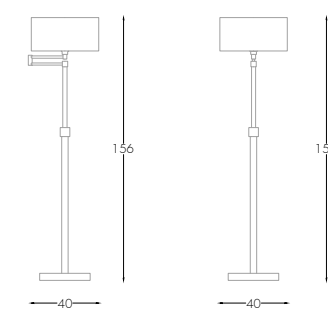

1.7

PIANTANA - FLOOR LAMP

00211 - Ø 50 x h. 160 cm

Struttura in ottone brunito con inserto godronato e rivestimento in cuoio. Paralume in raso Ecrù. Elettrificazione a norma CEE. Predisposta lampadine E27.

Structure in metal with burnished brass finish, knurled insert and upholstery in "cuoio" leather. Lampshade in Ecrù satin. EEC standard electric circuit. Ready for E27 bulb.

PAG.
Vol.2 - 124, 125, 154

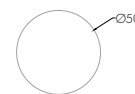
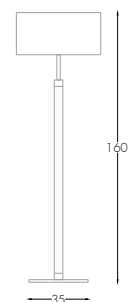

1.7

ABAT-JOUR - NIGHT LAMP

00212 - Ø 28 x h. 55 cm

Struttura in ottone brunito con inserto godronato e rivestimento in cuoio. Paralume in raso Ecrù. Elettrificazione a norma CEE. Predisposta lampadine E27.

Structure in metal with burnished brass finish, knurled insert and upholstery in "cuoio" leather. Lampshade in Ecrù satin. EEC standard electric circuit. Ready for E27 bulb.

PAG.
Vol.2 - 48, 49, 53, 154

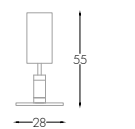

1.7

LAMPADA DA TAVOLO - TABLE LAMP

00213 - Ø 40 x h. 45 cm

Struttura in ottone brunito con inserto godronato e rivestimento in cuoio. Paralume in raso Ecrù. Elettrificazione a norma CEE. Predisposta lampadine E27.

Structure in metal with burnished brass finish, knurled insert and upholstery in "cuoio" leather. Lampshade in Ecrù satin. EEC standard electric circuit. Ready for E27 bulb.

PAG.
Vol.2 - 154, 155

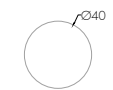
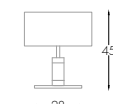

Skinny

PIANTANA - FLOOR LAMP

00110 - l. 30 x p. 56 x h. 145 cm

Struttura e paralume in ottone brunito. Elettrificazione a norma CEE. Led integrati.

Structure and shade in burnished brass. EEC standard electric circuit. Led integrated.

PAG.
Vol.2 - 72, 91, 165

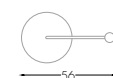
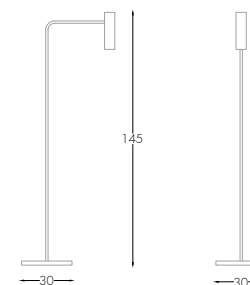

Skinny

LAMPADA DA TAVOLO - TABLE LAMP

00080 - l. 43 x p. 24 x h. 65 cm

Struttura e paralume in ottone brunito.
Elettrificazione a norma CEE. Led integrati.

Structure and shade in burnished brass. EEC
standard electric circuit. Led integrated.

PAG.
Vol.1 - 279, 377
Vol.2 - 164

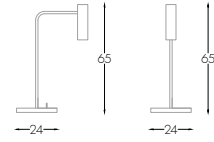

Skinny

ABAT-JOUR - NIGHT LAMP

00109 - l. 29 x p. 20 x h. 55 cm

Struttura e paralume in ottone brunito.
Elettrificazione a norma CEE. Led integrati.

Structure and shade in burnished brass. EEC
standard electric circuit. Led integrated.

PAG.
Vol.2 - 90, 93, 164

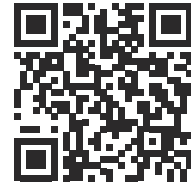
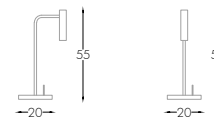

Plinto

PIANTANA - FLOOR LAMP

00174 - l. 50 x p. 38 x h. 170 cm

Struttura in legno con foderina noce dark laccata
lucida spazzolata e dettagli in ottone brunito.
Paralume in lino. Elettrificazione a norma CEE.
Predisposta per lampadina E27.

Wooden structure with dark walnut veneer, lacquered
brushed glossy finish and details in burnished brass.
Linen lampshade. EEC standard electric circuit.
Ready for E27 bulb.

PAG.
Vol.1 - 187, 348
Vol.2 - 10, 11, 78, 79, 162, 163

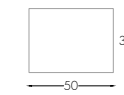
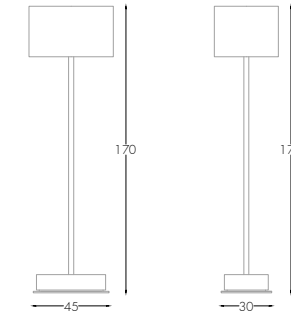

Plinto

PLINTO LAMPADA DA TAVOLO - TABLE LAMP

00175 - l. 55 x p. 20 x h. 50 cm

Struttura in legno con foderina noce dark laccata
lucida spazzolata e dettagli in ottone brunito.
Paralume in lino. Elettrificazione a norma CEE.
Predisposta per lampadina E27.

Wooden structure with dark walnut veneer, lacquered
brushed glossy finish and details in burnished brass.
Linen lampshade. EEC standard electric circuit.
Ready for E27 bulb.

PAG.
Vol.1 - 209, 210
Vol.2 - 162

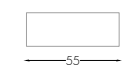
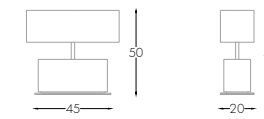

Plinto

ABAT-JOUR - NIGHT LAMP

00176 - l. 22 x p. 22 x h. 43 cm

Struttura in legno con foderina noce dark laccata lucida spazzolata e dettagli in metallo finitura ottone brunito. Paralume in lino. Elettrificazione a norma CEE. Predisposta per lampadina E27.

Wooden structure with dark walnut veneer, lacquered brushed glossy finish and details burnished brass. Linen lampshade. EEC standard electric circuit. Ready for E27 bulb.

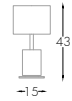

PAG.
Vol.1 - 183, 184, 187
Vol.2 - 80, 83, 162, 195



Brand

LAMPADA DA TAVOLO - TABLE LAMP

00027 - l. 50 x p. 30 x h. 70 cm

Struttura in ottone brunito. Paralume in lino. Elettrificazione a norma CEE. Predisposta per lampadina E27.

Structure in burnished brass. Linen lampshade. EEC standard electric circuit. Ready for E27 bulb.

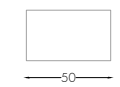
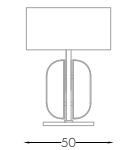

PAG.
Vol.1 - 220, 389
Vol.2 - 168, 189

Brand

PIANTANA - FLOOR LAMP

00029 - l. 55 x p. 35 x h. 180 cm

Struttura in ottone brunito. Paralume in lino. Elettrificazione a norma CEE. Predisposta per lampadina E27.

Structure in burnished brass. Linen lampshade. EEC standard electric circuit. Ready for E27 bulb.

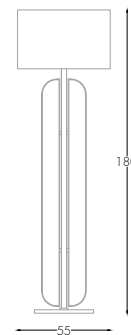

PAG.
Vol.2 - 115, 168, 169, 229



Brand

APPLIQUE - SCONCE

00056 - l. 40 x p. 16 x h. 68 cm

Struttura in ottone brunito. Paralume in lino. Elettrificazione a norma CEE. Predisposta per lampadina E27.

Structure in burnished brass. Linen lampshade. EEC standard electric circuit. Ready for E27 bulb.

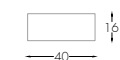
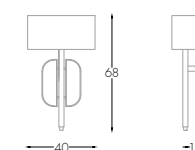

PAG.
Vol.2 - 168



Rindo

PIANTANA - FLOOR LAMP

00170 - Ø 55 x h. 170 cm

Struttura in legno con foderina noce dark lucida spazzolata e dettagli in ottone brunito. Paralume in lino. Elettrificazione a norma CEE. Predisposta per lampadina E27.

Wooden structure covered with brushed glossy dark walnut and burnished brass details. Lampshade in linen. EEC standard electric circuit. Ready for E27 bulb.

PAG.
Vol.1 - 182, 196, 346
Vol.2 160, 161

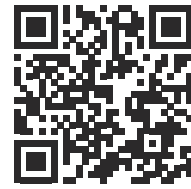
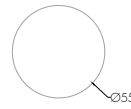
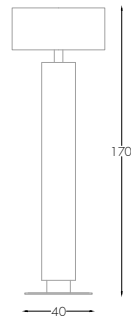

Rindo

LAMPADA DA TAVOLO - TABLE LAMP

00172 - Ø 32 x h. 50 cm

Struttura in legno con foderina noce dark lucida spazzolata e dettagli in ottone brunito. Paralume in lino. Elettrificazione a norma CEE. Predisposta per lampadina E27.

Wooden structure covered with brushed glossy dark walnut and burnished brass details. Lampshade in linen. EEC standard electric circuit. Ready for E27 bulb.

PAG.
Vol.1 - 163, 198, 200
Vol.2 - 58, 59, 65, 160

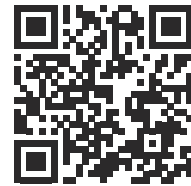
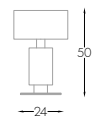

Rindo

ABAT-JOUR - NIGHT LAMP

00173 - Ø 26 x h. 38 cm

Struttura in legno con foderina noce dark lucida spazzolata e dettagli in ottone brunito. Paralume in lino. Elettrificazione a norma CEE. Predisposta per lampadina E27.

Wooden structure covered with brushed glossy dark walnut and burnished brass finish metal details. Lampshade in linen. EEC standard electric circuit. Ready for E27 bulb.

PAG.
Vol.1 - 163, 169
Vol.2 - 56, 60, 68, 69, 88, 89, 160

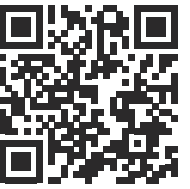

Jubilee

JUBILEE PIANTANA - FLOOR LAMP

00054 - l. 39 x p. 32 x h. 175,5 cm

Struttura in legno con trapuntatura a trama ondulata finitura foglia oro patinata lucida o finitura lucida effetto titanio. Paralume in lino. Elettrificazione a norma CEE. Predisposta per lampadina E27.

Solid linden structure with wavy texture. Glossy coated gold leaf or glossy titanium effect finishing. Linen lampshade. EEC standard electric circuit. Ready for E27 bulb.

PAG.
Vol.2 - 172, 173

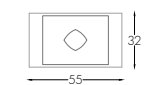
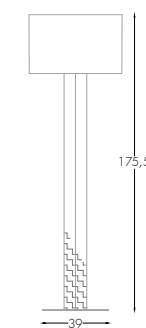

Jubilee

LAMPADA DA TAVOLO - TABLE LAMP

00073 - l. 40 x p. 25 x h. 80 cm

Struttura in legno con trapuntatura a trama ondulata finitura foglia oro patinata lucida o finitura lucida effetto titanio. Paralume in lino. Elettrificazione a norma CEE. Predisposta per lampadina E27.

Solid linden structure with wavy texture. Glossy coated gold leaf or glossy titanium effect finishing. Linen lampshade. EEC standard electric circuit. Ready for E27 bulb.

PAG.
Vol.2 - 84, 172

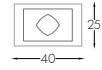
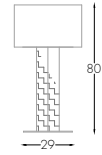

Jubilee

ABAT-JOUR - NIGHT LAMP

00074 - l. 30 x p. 20 x h. 60 cm

Struttura in legno con trapuntatura a trama ondulata finitura foglia oro patinata lucida o finitura lucida effetto titanio. Paralume in lino. Elettrificazione a norma CEE. Predisposta per lampadina E27.

Solid linden structure with wavy texture. Glossy coated gold leaf or glossy titanium effect finishing. Linen lampshade. EEC standard electric circuit. Ready for E27 bulb.

PAG.
Vol.2 - 104, 105, 106, 172

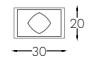
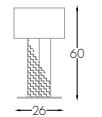

Gordon

PIANTANA - FLOOR LAMP

00214 - l. 133 x p. 35 x h. 190 cm

Struttura in ottone brunito con inserto godronato e rivestimento in cuoio. Paralume in raso Ecrù. Elettrificazione a norma CEE. Predisposta per lampadina E27.

Structure in burnished brass finish, knurled insert and upholstery in "cuoio" leather. Lampshade in Ecrù satin. EEC standard electric circuit. Ready for E27 bulb.

PAG.
Vol.2 - 158, 159

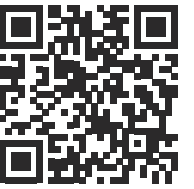
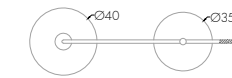
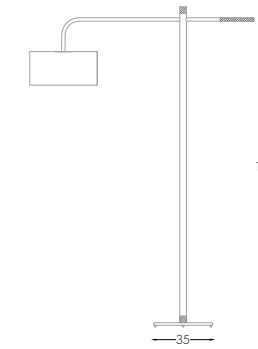

Weybridge

PIANTANA - FLOOR LAMP

00041 - Ø 45 x h. 150 cm

Struttura e paralume in ottone brunito. Elettrificazione a norma CEE. Predisposta per lampadina E27.

Structure and lampshade in burnished brass. EEC standard electric circuit. Ready for E27 bulb.

PAG.
Vol.1 - 267, 355
Vol.2 - 166, 167

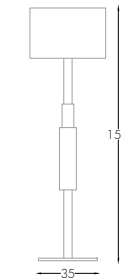

Weybridge

LAMPADA DA TAVOLO - TABLE LAMP

00042 - Ø 40 x h. 65 cm

Struttura e paralume in ottone brunito.
Elettrificazione a norma CEE.
Predisposta per lampadina E27.

Structure and lampshade in burnished brass.
EEC standard electric circuit.
Ready for E27 bulb.

PAG.
Vol.2 - 96, 109, 111, 166, 201

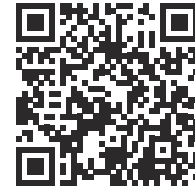
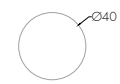
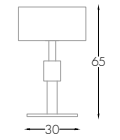

Moon

LAMPADA DA TAVOLO - TABLE LAMP

00072 - Ø 30 x h. 60 cm

Struttura in ottone brunito con trapuntatura cannetté.
Paralume in lino. Elettrificazione a norma CEE.
Predisposta per lampadina E27.

Structure in burnished brass and quilted with
cannetté motive. Linen lampshade. EEC standard
electric circuit. Ready for E27 bulb.

PAG.
Vol.1 - 235, 366, 367, 392
Vol.2 - 170, 171

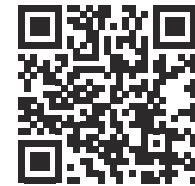
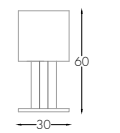

Bamboo

PIANTANA - FLOOR LAMP

00177 - l. 35 x p. 35 x h. 181 cm

Struttura e paralume in ottone brunito.
Elettrificazione a norma CEE, led integrato.
Predisposta per lampadina E27.

Structure and lampshade in burnished brass.
EEC standard electric circuit. Included led.
Ready for E27 bulb.

PAG.
Vol.1 - 162, 163, 214, 231
Vol.2 - 63, 186, 187

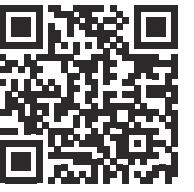
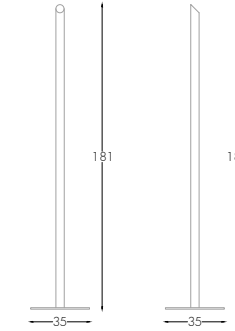

Bamboo

LAMPADARIO - CHANDELIER

00179 - l. 45 x p. 45 x h. 100 cm

Struttura e paralume in ottone brunito.
Elettrificazione a norma CEE, led integrato.
Predisposta per lampadina E27.

Structure and lampshade in burnished brass.
EEC standard electric circuit. Included led.
Ready for E27 bulb.

PAG.
Vol.1 - 340
Vol.2 - 186

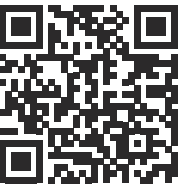
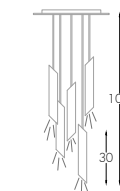

Bamboo

APPLIQUE - SCONCE

00178 - l. 7 x p. 9 x h. 35 cm

Struttura e paralume in ottone brunito.
Elettrificazione a norma CEE, led integrato.
Predisposta per lampadina E27.

Structure and lampshade in burnished brass.
EEC standard electric circuit. Included led.
Ready for E27 bulb.

PAG.
Vol.2 - 186

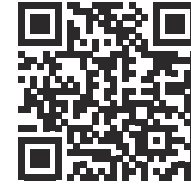
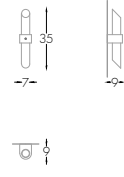

Blow up

LAMPADARIO - CHANDELIER

00288 - l. 108 x p. 108 x h. 106 cm

Struttura in ottone satinato.
N.16 lampadine E27 incluse.

Satin brass structure.
N.16 E27 bulbs included.

PAG.
Vol.1 - 286,287
Vol.2 - 176, 177

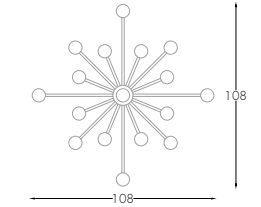
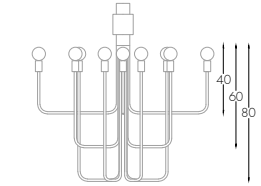

NYC

LAMPADARIO - CHANDELIER

00270 - Ø 100 x h. 100 cm

Struttura in ottone satinato, led integrati. Quadriedri pendenti in cristallo bianco, cristallo fumé e cristallo ambra. Led integrati.

Satin brass structure, integrated led. Prism pendants in white crystal, smoke-grey crystal and amber crystal. Included led.

PAG.
Vol.2 - 174, 175

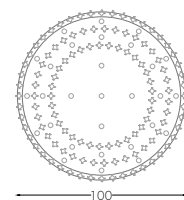
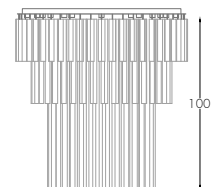

Tab

LAMPADARIO - CHANDELIER

00267 - l. 120 x p. 30 x h. 55 cm

Struttura in ottone satinato, led integrati e dettagli in cristallo naturale e cristallo fumé, sospensione con cavetti in acciaio regolabili.

Satin brass structure, integrated led and details in white crystal and smoke-grey crystal, hang chain with adjustable steel cables.

PAG.
Vol.1 - 308, 309
Vol.2 - 178, 179

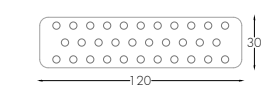
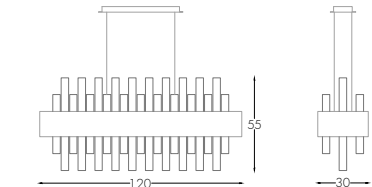

Teo

LAMPADARIO - CHANDELIER

00271 - l. 45 x p. 38 x h. 119 cm

Struttura regolabile in altezza in ottone satinato, sfera in cristallo satinato opaco, predisposto per lampadina E27.

Height adjustable structure in satin brass, opaque satin crystal ball, ready for E27 bulb

PAG.
Vol.1 - 315
Vol.2 - 180, 181

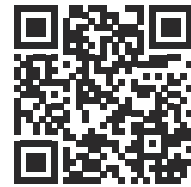
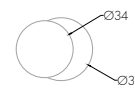
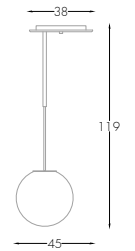

Barrique

ABAT-JOUR - NIGHT LAMP

00031 - l. 30 x p. 30 x h. 60 cm

Struttura in ottone brunito. Paralume in lino. Elettrificazione a norma CEE. Predisposta per lampadine E14.

Structure in burnished brass. Linen shade. EEC standard electric circuit. Ready for E14 bulbs.

PAG.
Vol.1 - 243, 246, 266, 270
Vol.2 - 16, 116, 117, 119, 128, 156, 157



Barrique

LAMPADARIO - CHANDELIER

00017 - l. 90 x p. 90 cm

Struttura in ottone brunito. Paralume in lino. Elettrificazione a norma CEE. Predisposta per lampadine E14.

Structure in burnished brass. Linen shade. EEC standard electric circuit. Ready for E14 bulbs.

PAG.
Vol.2 - 188, 189

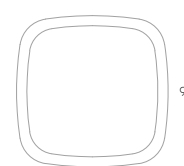
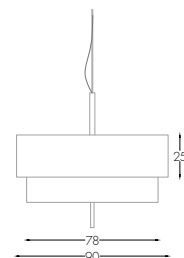

Fish

LAMPADARIO - CHANDELIER

00099 - l. 120 x p. 8 x h. 50 cm

Struttura in ottone brunito. Led integrati. Elettrificazione a norma CEE.

Structure in burnished brass. EEC standard electric circuit. Included led.

PAG.
Vol.1 - 392, 393
Vol.2 - 184, 185

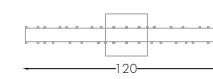
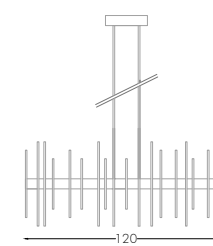

Alfred

LAMPADARIO . CHANDELIER

00210 - Ø 120 x H. 40 cm

Struttura in ottone brunito. Paralume in ecopelle trapuntatura a rombi, inserto in ottone brunito e bottoni logati. Elettrificazione a norma CEE. Predisposto per n.4 lampadine E27.

Structure in burnished brass. Faux leather shade with diamond quilting. Burnished brass insert and buttons with logo. EEC standard electric circuit. Ready for n.4 E27 bulbs.

PAG.
Vol.2 - 182, 183

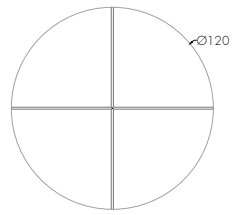
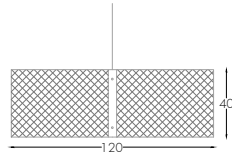

Valencia

00217 - l. 60 x p. 4 x h. 40 cm

Boiserie in mirto grey con particolari in ottone.

Grey myrtle boiserie with brass details

PAG.
Vol.2 - 234, 235

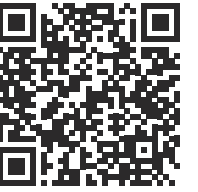
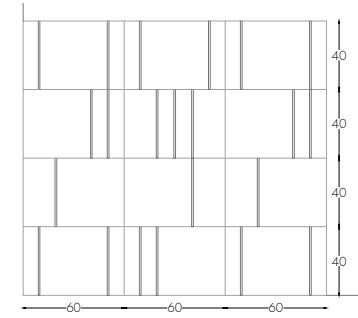
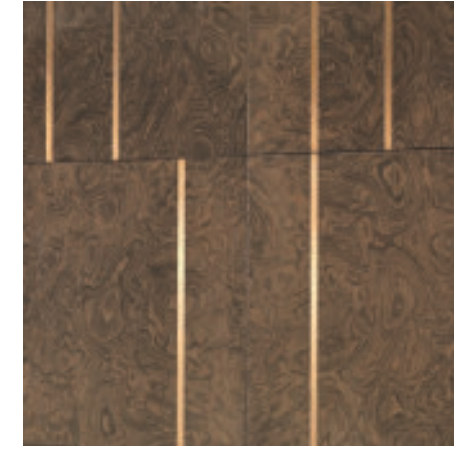

Florence

00111 - l. 300 x h. 240 cm

Boiserie in pelle o nabuk con particolari in metallo finitura ottone o titanio.

Wainscoting in leather or nabuk with metal details, brass or titanium finish.

PAG.
Vol.2 - 236, 237

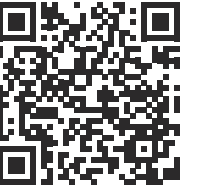
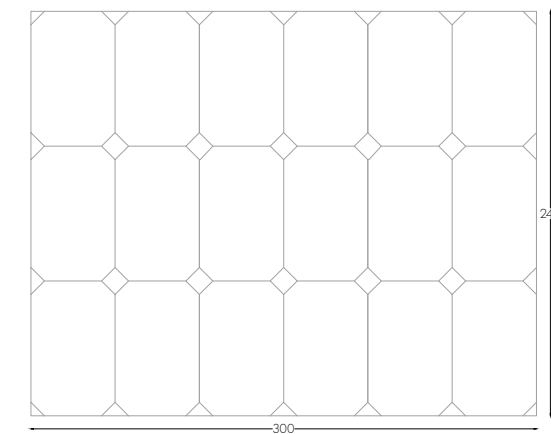

Boiserie in Noce Dark

00100 - l. 195 x h.195 cm

Boiserie in noce dark.

Wainscoting in dark walnut.

PAG.

Vol.2 - 238, 239

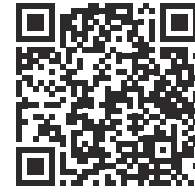
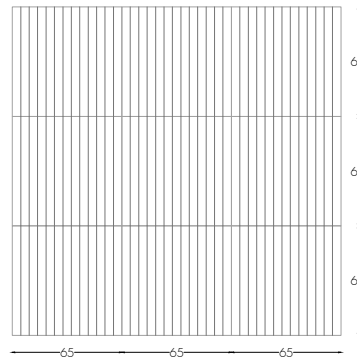
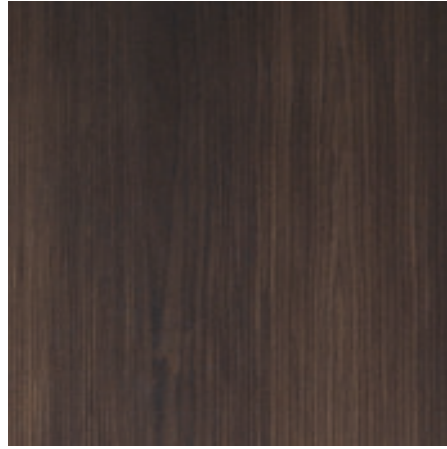

Boiserie in Pelle

00100/P - l. 195 x h.195 cm

Boiserie in pelle.

Wainscoting leather or nabuk quilted with cannettè motive.

PAG.

Vol.2 - 238, 239

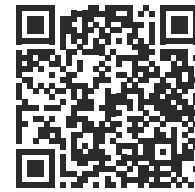
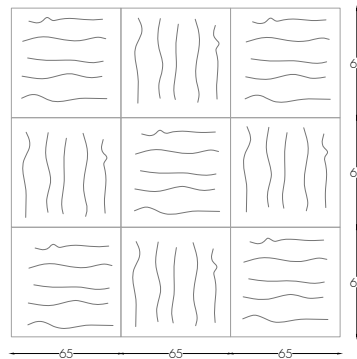
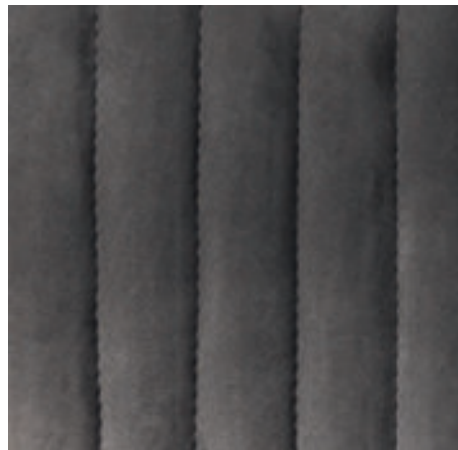

Nubia

00219

TAPPETO - CARPET

TAPPETI SU MISURA A RICHIESTA
CUSTOM MADE CARPETS

Taftato a mano con rifiniture manuali.

Materiali: lana 60%, cotone 20%, viscosa 20%
Dorso spalmato in latex e foderato cotone.
Peso netto kg 4,5 al metro quadro.

Rug tufted and finished by hand.

Materials: wool 60%, cotton 20%, viscose 20%
Back coated in latex and lined in cotton.
Net weight 4.5 kg per square meter.

PAG.

Vol.2 - 204, 205



Sahara

00220

TAPPETO - CARPET

TAPPETI SU MISURA A RICHIESTA
CUSTOM MADE CARPETS

Taftato a mano con rifiniture manuali.

Materiali: lana 60%, cotone 20%, viscosa 20%
Dorso spalmato in latex e foderato cotone.
Peso netto kg 4,5 al metro quadro.

Rug tufted and finished by hand.

Materials: wool 60%, cotton 20%, viscose 20%
Back coated in latex and lined in cotton.
Net weight 4.5 kg per square meter.

PAG.

Vol.2 - 202, 203

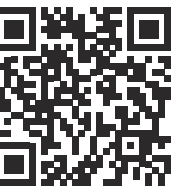

Luxor

00221
TAPPETO - CARPET

TAPPETI SU MISURA A RICHIESTA
CUSTOM MADE CARPETS

Taftato a mano con rifiniture manuali.
Materiali: lana 60%, cotone 20%, viscosa 20%
Dorso spalmato in latex e foderato cotone.
Peso netto kg 4,5 al metro quadro.

Rug tufted and finished by hand.
Materials: wool 60%, cotton 20%, viscose 20%
Back coated in latex and lined in cotton.
Net weight 4.5 kg per square meter.

PAG.
Vol.2 - 206, 207



Brand

00117
TAPPETO - CARPET

l. 460 x 400 cm

Taftato a mano con rifiniture manuali.
Materiali: lana 60%, cotone 20%, viscosa 20%
Dorso spalmato in latex e foderato cotone.
Peso netto kg 4,5 al metro quadro.
Dettagli in ottone.

Rug tufted and finished by hand.
Materials: wool 60%, cotton 20%, viscose 20%
Back coated in latex and lined in cotton.
Net weight 4.5 kg per square meter.
Brass details.

PAG.
Vol.2 - 208, 209

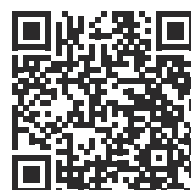

Holly

SPECCHIO - MIRROR

00304 - l. 12 x p. 12 x h. 42 cm
Mirror - Ø 12

Basamento in marmo Calacatta oro, telaio in acciaio
finitura ottone, specchio girevole applicato su
pannello in frassino finitura nero opaco.

Base in Calacatta gold marble, steel frame with brass
finish, turning mirror applied on an ashwood panel
with opaque black finish.

PAG.
Vol.2 - 106, 198, 199

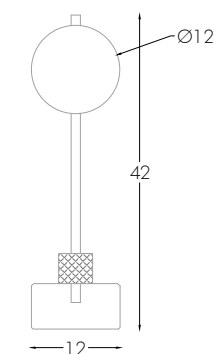

Moira

SPECCHIO - MIRROR

00301 - l. 26 x p. 16 x h. 42 cm
Mirror - Ø 21,5

Basamento in marmo Calacatta oro, telaio in acciaio
finitura ottone, specchio oscillante applicato su
pannello in frassino finitura nero opaco.

Base in calacatta gold marble, steel frame with brass
finish, tilting mirror applied on an ashwood panel with
opaque black finish.

PAG.
Vol.2 - 76, 82, 314, 200, 201

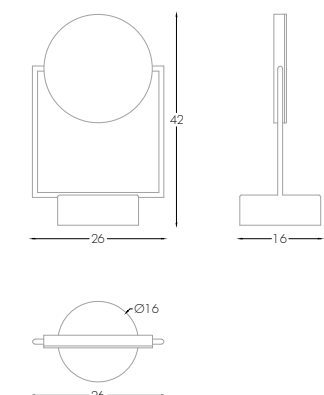

Fermacarte

FERMACARTE - PAPERWEIGHT

00299 - Ø 8 x h. 4,5 cm

Struttura in metallo godronato,
finitura ottone satinato.

Knurled metal structure with satin brass finish.

PAG.
Vol.2 - 192, 193



Portacandela

PORTACANDELA MEDIO - MEDIUM CANDLE
HOLDER

00300/M - Ø 5 x h.15 cm

Struttura in metallo finitura ottone satinato.

Metal structure with satin brass finish.

PAG.
Vol.2 - 192, 193

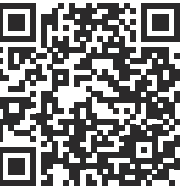

Portacandela

PORTACANDELA - CANDLE HOLDER

00300 - Ø 6 x h. 8 cm

Struttura in metallo finitura ottone satinato.

Metal structure with satin brass finish.

PAG.
Vol.2 - 192, 193

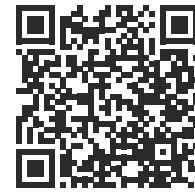
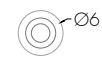

Portacandela

PORTACANDELA GRANDE - BIG CANDLE
HOLDER

00300/G - Ø 6 x h. 20 cm

Struttura in metallo finitura ottone satinato.

Metal structure with satin brass finish.

PAG.
Vol.2 - 192, 193

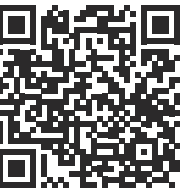
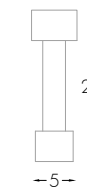

Scultura

SCULTURA - SCULPTURE

00302 - Ø 15 x h. 35 cm

Struttura in acciaio finitura ottone satinato.

Steel structure with satin brass finish.

PAG.
Vol.2 - 192, 193

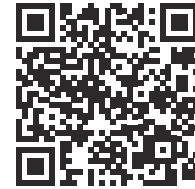
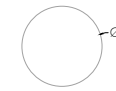
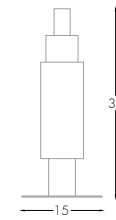

Scultura

SCULTURA ALTA - TALL SCULPTURE

00302/A - Ø 12 x h. 40 cm

Base in marmo Calacatta oro, struttura in acciaio finitura ottone satinato.

Base in Calacatta gold marble, steel frame with brass finish.

PAG.
Vol.2 - 192, 193

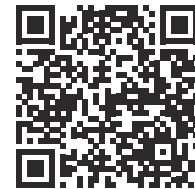
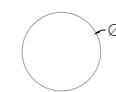
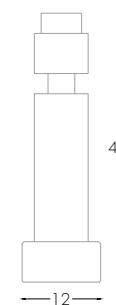

Vaso basso

VASO - VASE

00303 - Ø 8 x h. 28 cm

Base in marmo Calacatta oro, struttura in acciaio finitura ottone satinato.

Base in Calacatta gold marble, steel frame with brass finish.

PAG.
Vol.2 - 192, 193

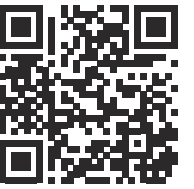

Vaso alto

VASO ALTO - TALL VASE

00303/A - Ø 8 x h. 43 cm

Base in marmo Calacatta oro, struttura in acciaio finitura ottone satinato.

Base in Calacatta gold marble, steel frame with brass finish.

PAG.
Vol.2 - 192, 193

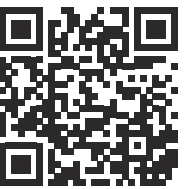

Porta gioie

COFANETTO PORTA GIOIE - JEWEL CASE

00283 - l. 14,8 x p. 14,8 x h. 10 cm

Struttura in multistrati di frassino, finitura nero opaco, coperchio in ottone satinato.

Ash plywood structure, with opaque black finish, satin brass lid.

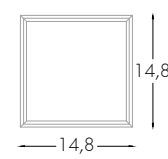
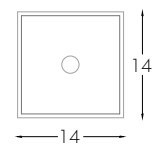
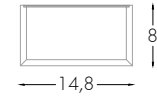

Tito

VASSOIO - TRAY

00285 - l. 30 x p. 20 x h. 5 cm

Porta oggetti in acciaio rivestito in cuoio.

Steel box for knickknacks lined in leather.

PAG.
Vol.1 - 108
Vol.2 - 194, 195

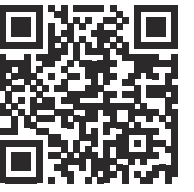
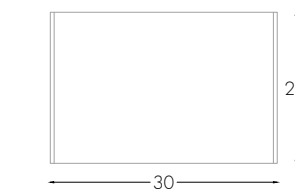
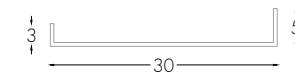

Forbes

PORTA RIVISTE - MAGAZINE RACK

00284 - l. 32 x p. 9 x h. 31 cm

Struttura in ottone satinato ed acciaio rivestito in cuoio.

Satin brass structure lined with leather.

PAG.
Vol.2 - 47, 196, 197

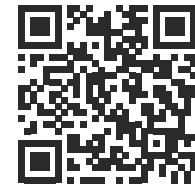
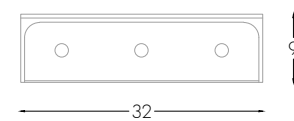
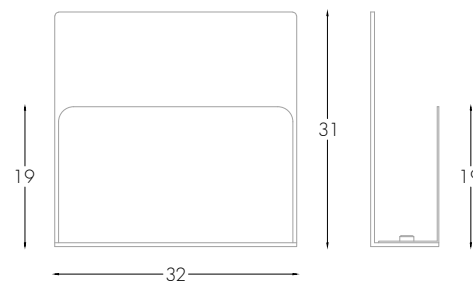

Profumo

PROFUMO - PERFUME

00121 PROFUMO GRANDE - LARGE PERFUME
00122 PROFUMO PICCOLO - SMALL PERFUME

Fragranze personalizzate prodotte appositamente ed esclusivamente per il brand Daytona, frutto di uno studio che rispecchia il carattere della collezione.

Exclusive personalized fragrances produced especially for the Daytona brand. The result of a research aimed to reflect the character of the collection.



Tessuti per paralumi
Lamp shade fabrics



RASO ECRÙ



RASO NERO



LINO



ECOPELLE SABBIA

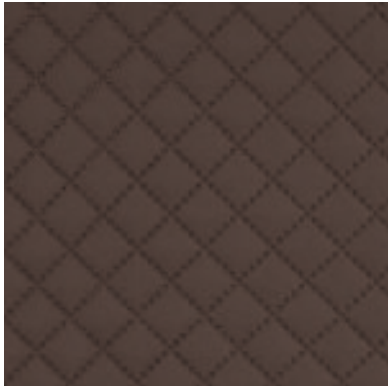

ECOPELLE MOKA

Legno a trama ondulata
Wavy pattern wood

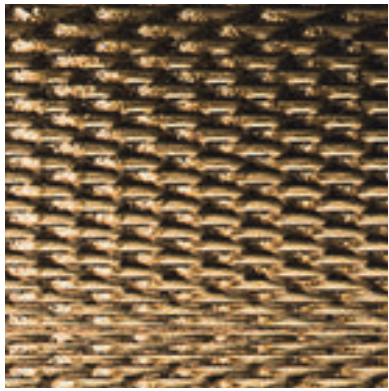

FOGLIA ORO PATINATA LUCIDA
GLOSSY COATED GOLD LEAF

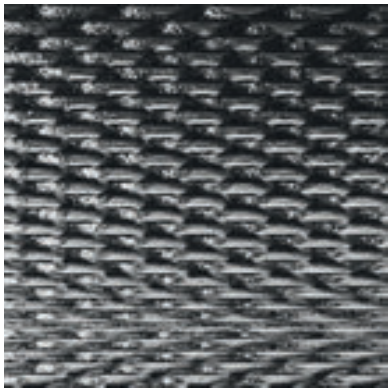

FINITURA LUCIDA EFFETTO TITANIO
GLOSSY TITANIUM EFFECT
FINISHING

Essenze
Wood finishes

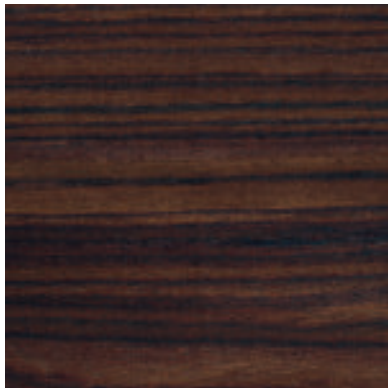

NOCE DARK GLOSSY

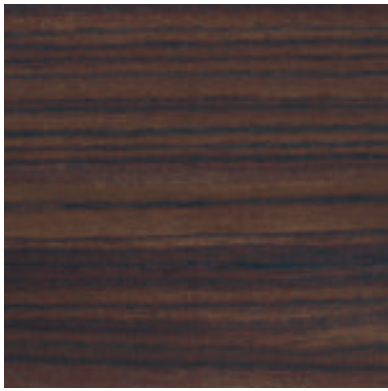

NOCE DARK MATT



MIRTO GLOSSY



MIRTO MATT



MIRTO GREY

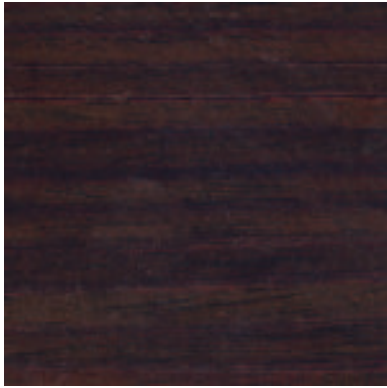

EBONY



MIRTO NERO

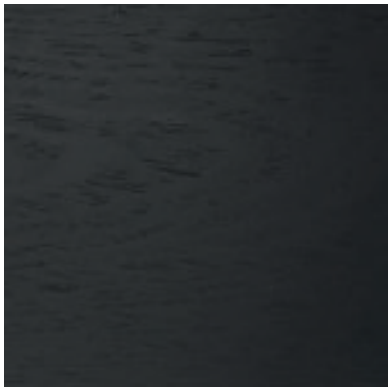

FRASSINO NERO PORO APERTO

Laccati
Lacquered finishes

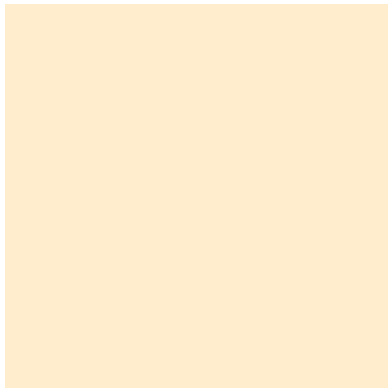

AVORIO



FUMO



CANAPA

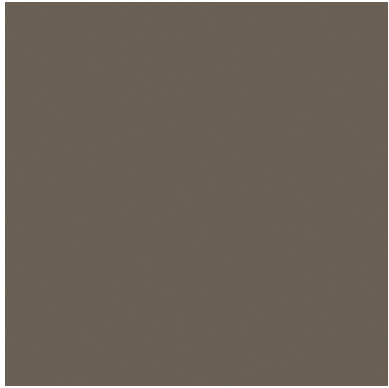

VISONE



SIENNA



POSITANO



NERO



CHIANTI

Vetri, specchi e metalli

Glasses, mirrors and metals

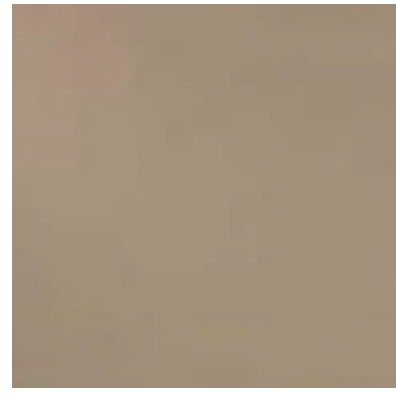

VETRO BRONZO - BRONZE GLASS



SPECCHIO BRONZO - BRONZE MIRROR



VETRO LACCATO NERO - LAQUERED BLACK GLASS



VETRO FUMÈ - SMOKED GLASS



SPECCHIO FUMÈ - SMOKED MIRROR



OTTONE FINITURA TITANIO - BRASS WITH TITANIUM FINISHING



OTTONE BRUNITO - BURNISHED BRASS



OTTONE SATINATO - SATIN BRASS

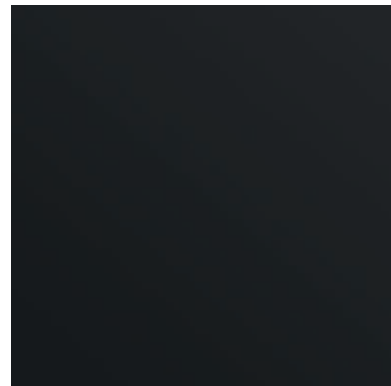

ACCIAIO LACCATO NERO OPACO - LAQUERED INOX BLACK MATT

Tessuti

Fabrics

Cat. A



SAILOR 01 SABBIA



SAILOR 09 BLU



SAILOR 11 NATURALE



SAILOR 46 MOKA



SAILOR 121 GHIACCIO

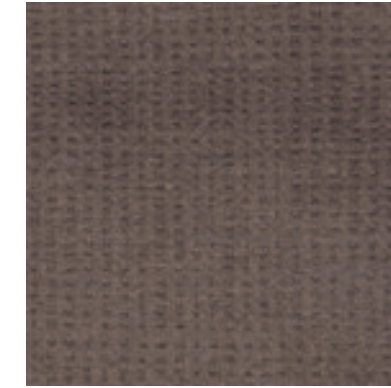

SAILOR 165 MARMOTTA



SAILOR 429 VERDE

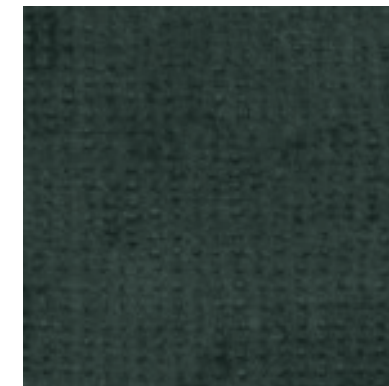

SAILOR 435 BOSCO



SAILOR 705 JEANS

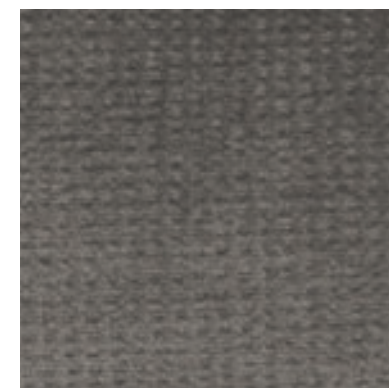

SAILOR 740 TORTORA



SAILOR 1670 CORALLO

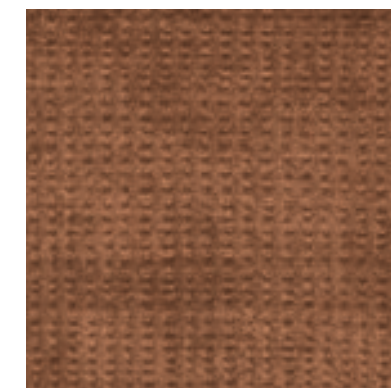

SAILOR 1898 TERRACOTTA



MOON LIGHT 104 CANAPA



MOON LIGHT 10 PORTOFINO



MOON LIGHT 14 AVIO



MOON LIGHT 20 TORTORA



MOON LIGHT 04 CAMMELLO



MOON LIGHT 03 DUNE



MOON LIGHT 11 VISONE



MOON LIGHT 100 CIOCCOLATO



MOON LIGHT 18 NERO

Tessuti Fabrics

Cat. B

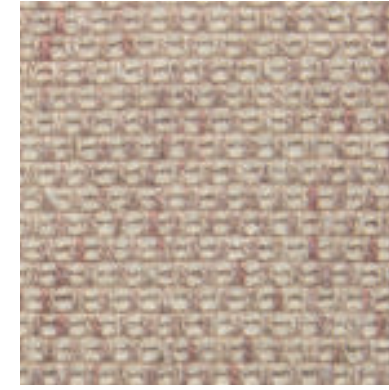

INFINITY 01 NATURALE

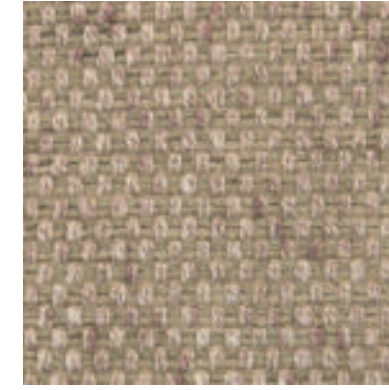

INFINITY 02 SACCO

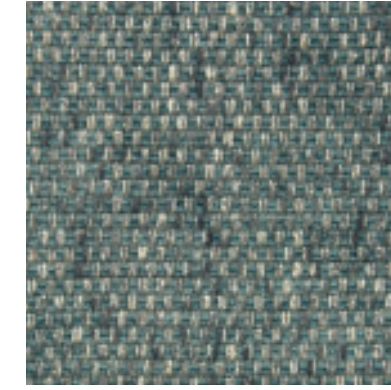

INFINITY 14 PETROLIO

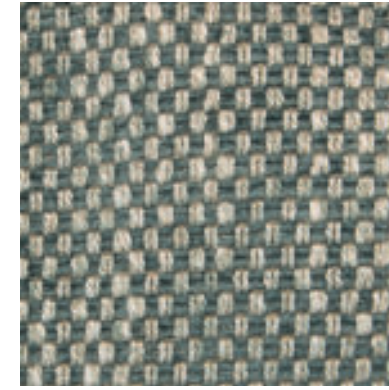

INFINITY 15 FELCE

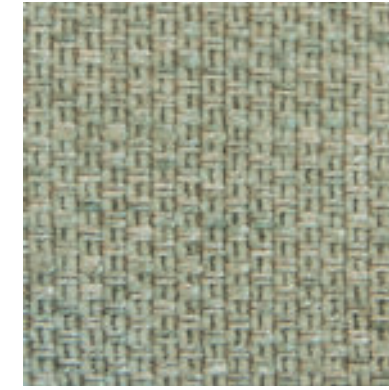

INFINITY 16 SALVIA

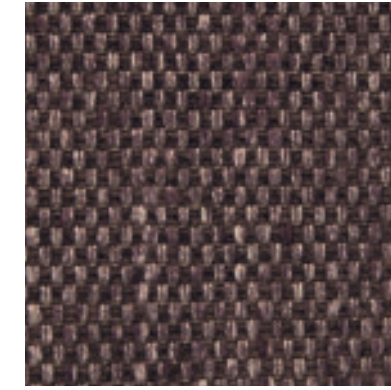

INFINITY 18 MORO



ANGEL 10 NATURALE



ANGEL 13 SABBIA



ANGEL 14 ARMY



ANGEL 26 LORD



LULY 02 GESSO



LULY 05 ARGENTO

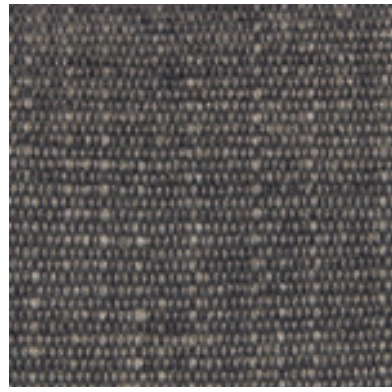

LULY 06 CENERE



LULY 09 MOKA



LULY 10 VISONE



LULY 14 CIELO



LULY 22 BEIGE



LULY 31 ANTRACITE



LULY 36 OCRA

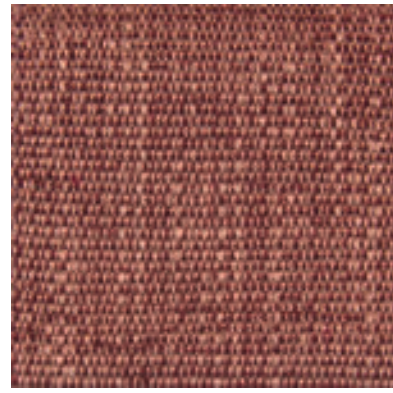

LULY 38 BORDEAUX

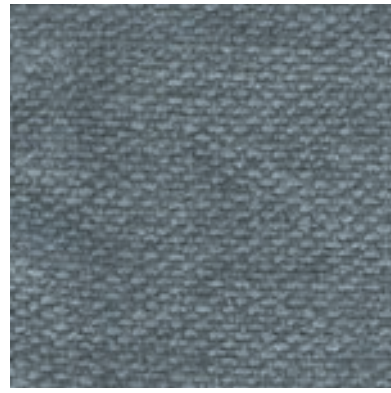

HAVANA 17 AVIO

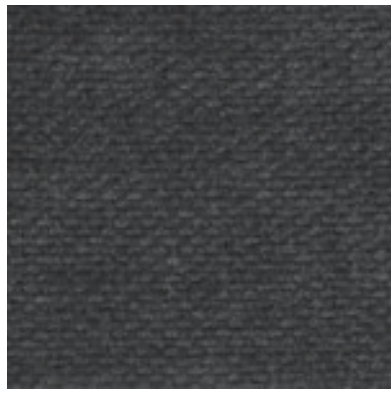

HAVANA 205 ANTRACITE



HAVANA 1 BEIGE



HAVANA 12 TORTORA

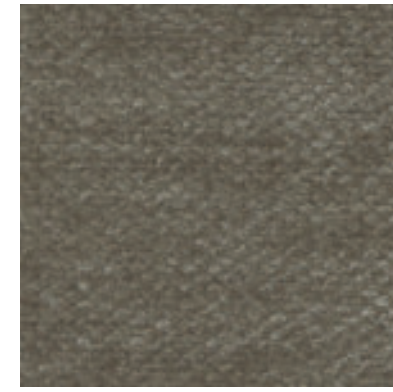

HAVANA 622 CRETA

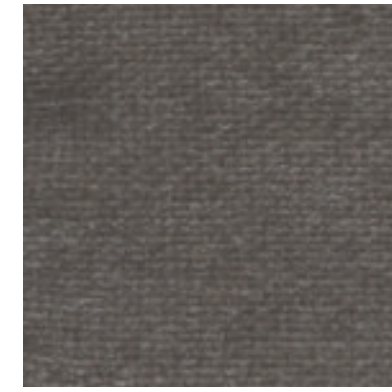

HAVANA 2 FANGO

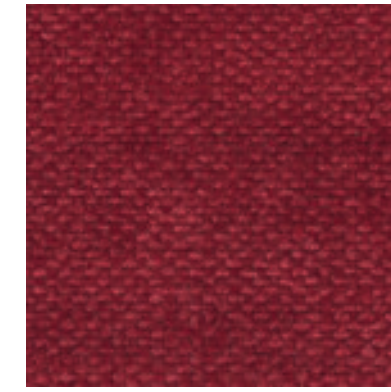

HAVANA 10 ROSSO



NICE 113 CONCHIGLIA



NICE 121 SABBIA



NICE 127 ARDESIA



OLIVER 58 NAVY



OLIVER 1405 VINO



OLIVER 1406 AVIO



OLIVER 2003 GRIGIO



OLIVER 23 SABBIA



OLIVER 05 CASTAGNA



OLIVER 2012 MARMOTTA



OLIVER 2002 MOKA



OLIVER 14 ZUCCA



OLIVER 1402 MUSCHIO



OLIVER 54 COBALTO



OLIVER 29 GHIACCIO



OLIVER 1404 GHISA



VELVET 02 PANNA



VELVET 1720 BEIGE



VELVET 1709 MILITARE



VELVET 1715 CAMMELLO

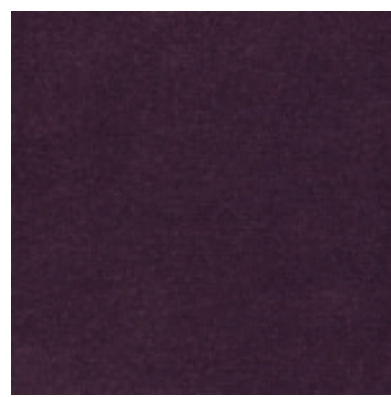

VELVET 09 MELANZANA



VELVET 04 CRETA



VELVET 08 CIOCCOLATO



VELVET 12 PRUSSIA



VELVET 11 GRIGIO



VELVET 1708 TERRA



VELVET 28 MATTONE



VELVET 35 CIPRIA



VELVET 111 CARTA DA ZUCCHERO



VELVET 1004 SENAPE



VELVET 19 CROMO

Pelli
Leathers

Cat. A

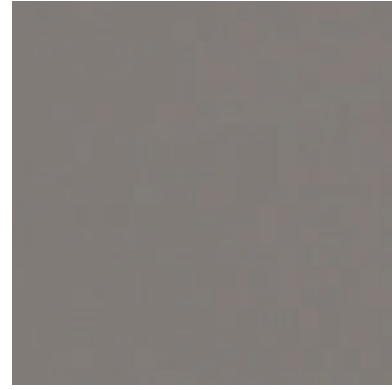

CLAYTON 1660 GRIGIO



CLAYTON 1639 LUMIERE

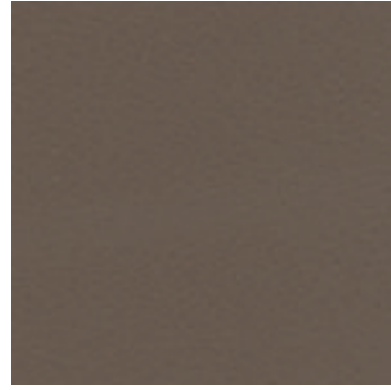

CLAYTON 1627 TORTORA

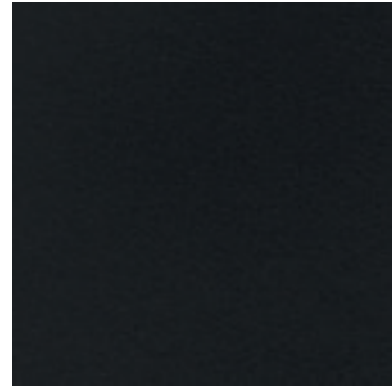

CLAYTON 1101 NERO



CLAYTON 1108 CHIANTI



CLAYTON 1147 DARK



CLAYTON 1179 GESSO

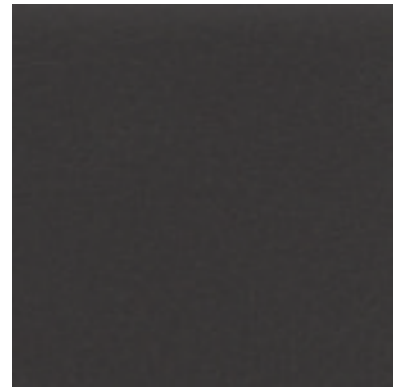

CLAYTON 1216 FANGO



CLAYTON 1226 BEIGE

Pelli
Leathers

Cat. B



BALI 02 COTTO



BALI 17 TABACCO



BALI 04 TESTA DI MORO



BALI 07 BLACK



BALI 10 SABBIA



BALI 11 FUMO



BALI 15 GREIGE



CAMOSCIO 8 FANGO

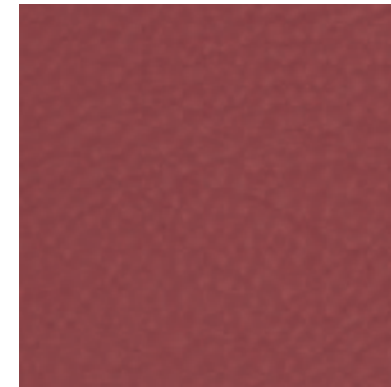

CAMOSCIO 16 PORTOFINO



CAMOSCIO 21 NAMIBIA



CAMOSCIO 23 DUNE



CAMOSCIO 26 GRIGIO



CAMOSCIO 31 PERLA

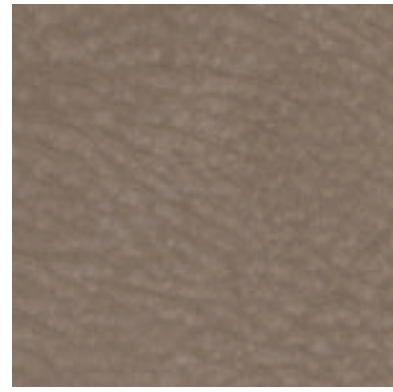

CAMOSCIO 27 TORTORA

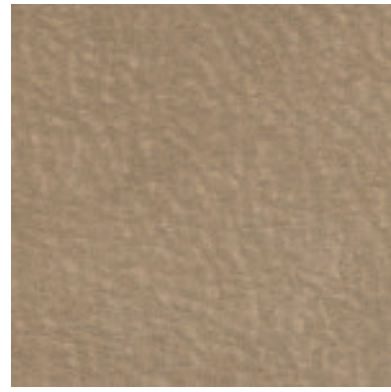

CAMOSCIO 32 CORDA



CAMOSCIO 34 MOKA

Pelli Leathers

Cat. C



DELUXE 01 NERO

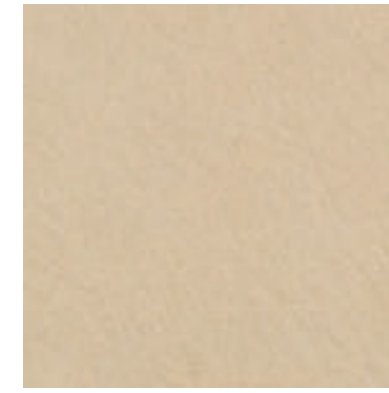

DELUXE 03 CREAM



DELUXE 05 DUNE

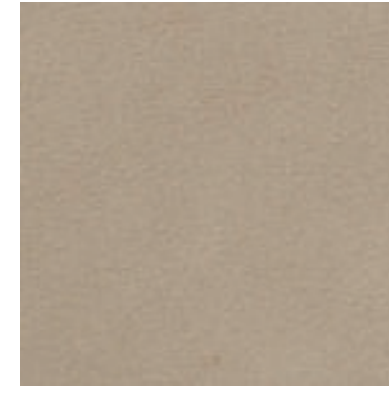

DELUXE 08 GREIGE



DELUXE 09 ARDESIA



DELUXE 18 STONE



DELUXE 21 TERRA



DELUXE 22 BROWN



DELUXE 23 ARGILLA

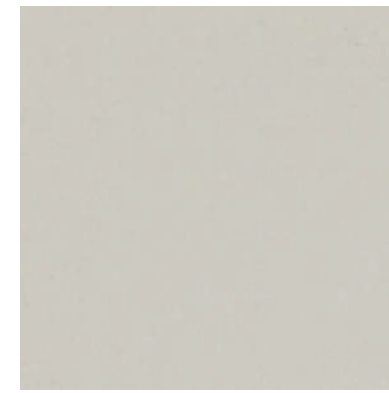

DELUXE 24 GESSO

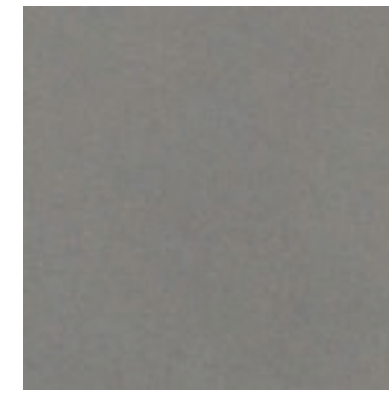

DELUXE 25 CEMENTO

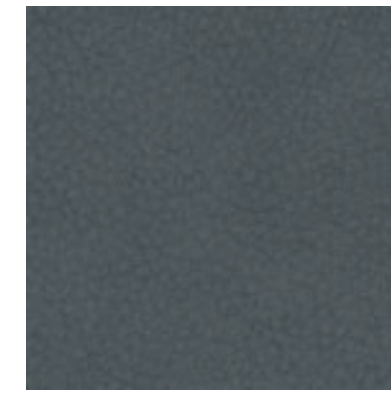

NABUK 2117 FERRO

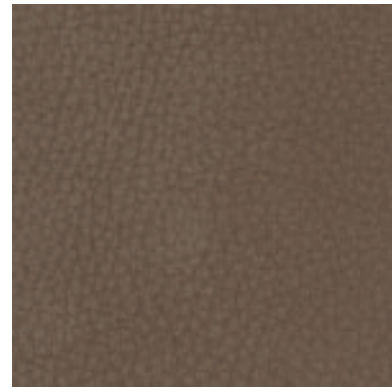

NABUK 2116 TABACCO

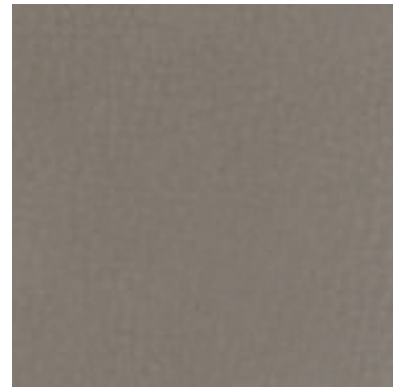

NABUK 2115 TORTORA



NABUK 2114 CIOCCOLATO



NABUK 2100 GESSO



NABUK 2101 SABBIA



NABUK 2118 CANAPA

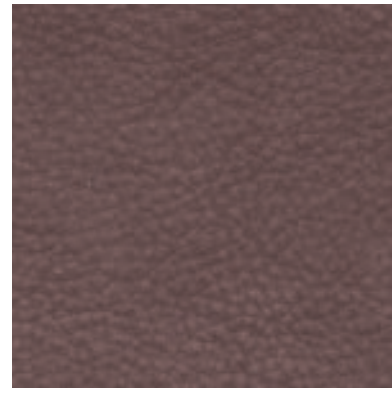

NABUK 10 ROSA ANTICO

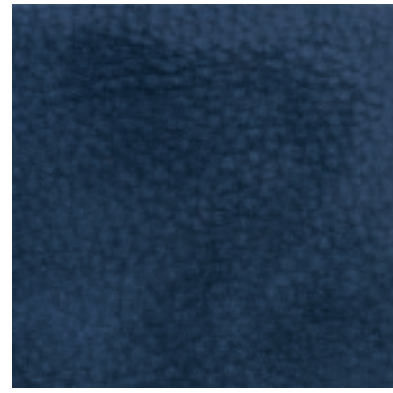

NABUK 18 BLU

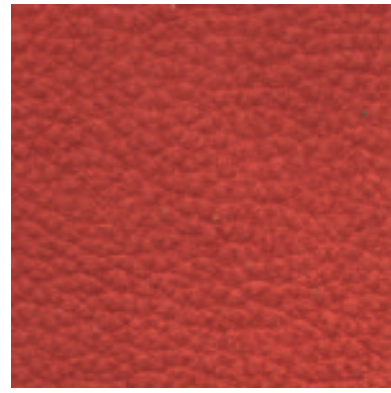

NABUK 21 ROSSO



NABUK 22 OCRA

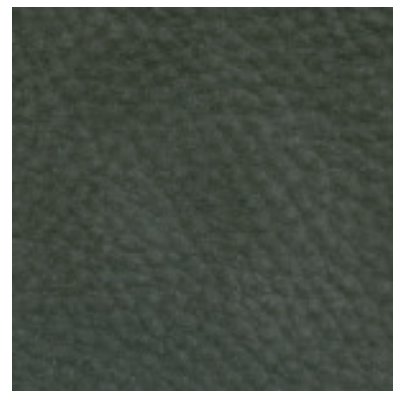

NABUK 24 MUSCHIO

Cuoio Leather



CUOIO BEIGE

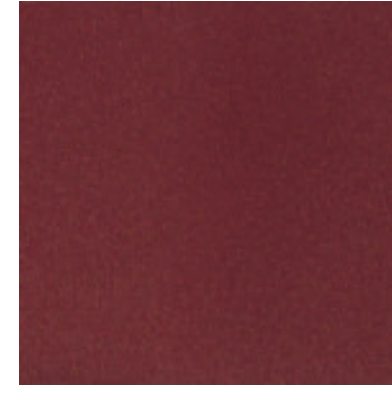

CUOIO BORDEAUX

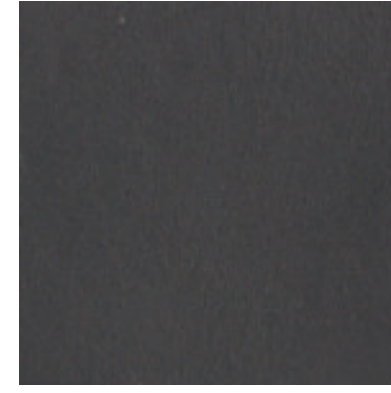

CUOIO GRIGIO



CUOIO INVECCHIATO

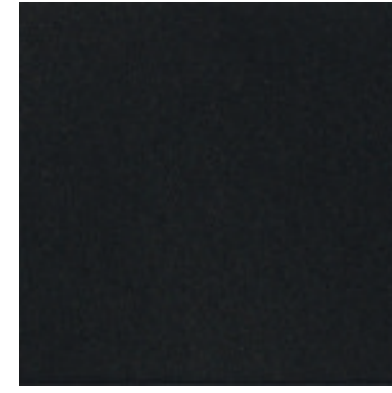

CUOIO NERO



CUOIO TESTA DI MORO

Stampe

Embossed leather



F/11 STAMPA JUBILEÉ

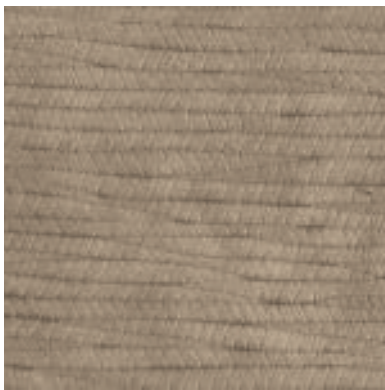

F/10 STAMPA KORDA

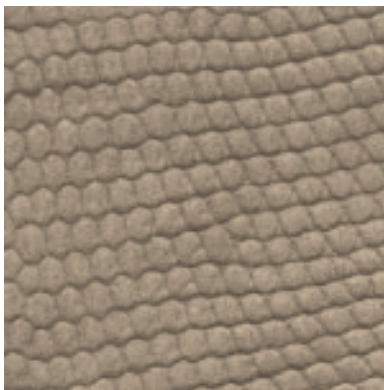

STAMPA KUBA

ESEMPI DI STAMPA RIPRODUCIBILI
SU TUTTO IL CAMPIONARIO PELLE,
NABUK E CAMOSCIO.

SAMPLES OF PRINTS
REPRODUCIBLE ON
ALL KIND OF LEATHER, NUBUCK
AND SUEDE.

Marmi
Marble

Cat. A



EMPERADOR

Marmi
Marble

Cat. B



RAIN FOREST BROWN

Cat. B

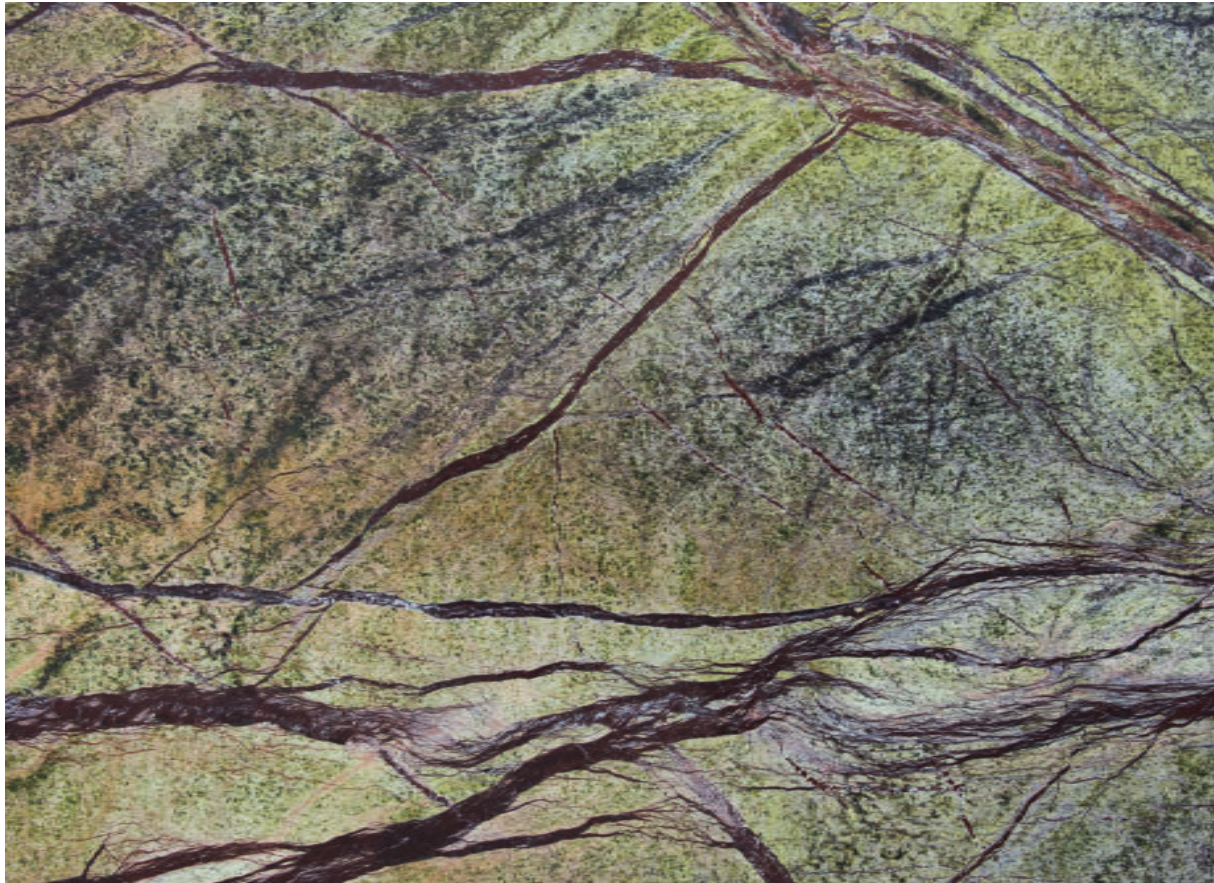

RAIN FOREST GREEN

Cat. C



AGATHA BLACK

Marmi
Marble

Cat. C

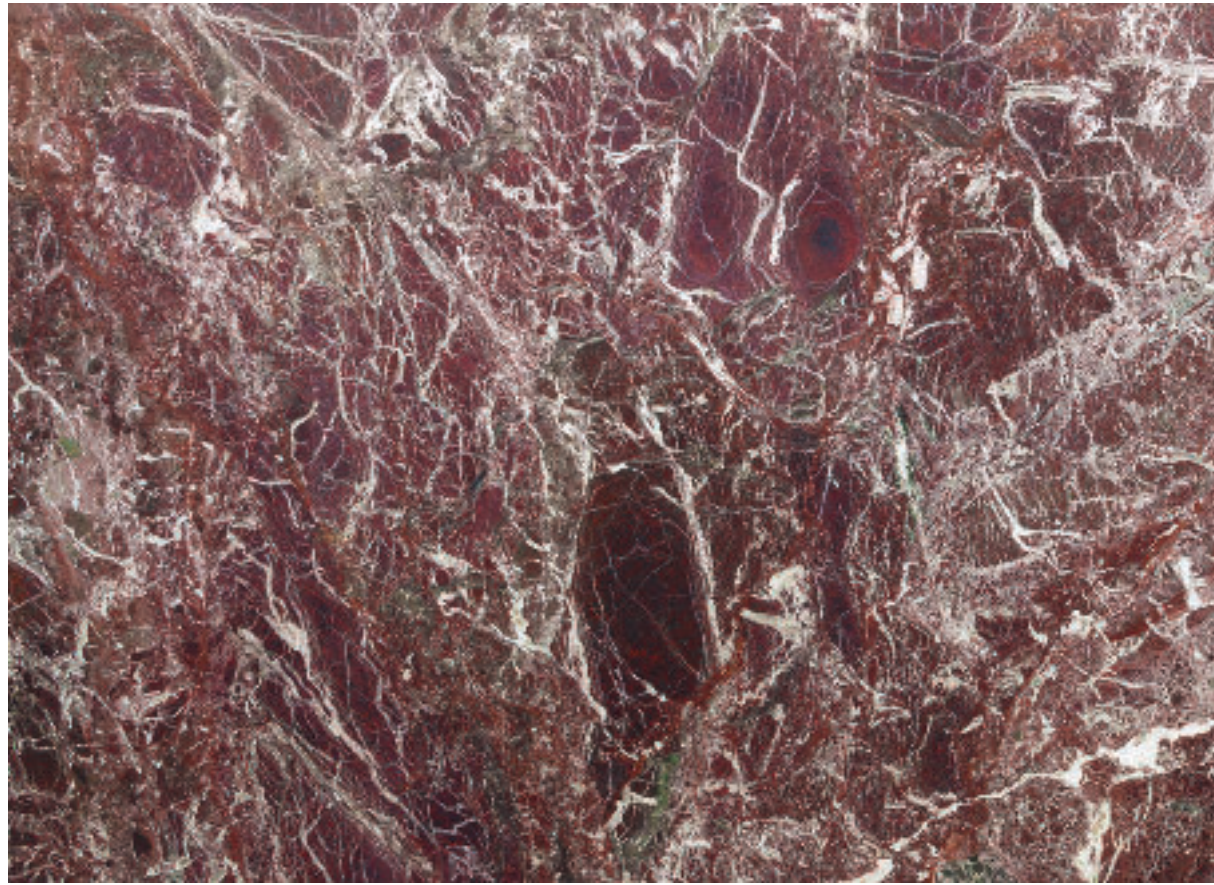

ROSSO LEVANTO

Cat. C



FIORI DI BOSCO

Marmi
Marble

Cat. C



SILVER ROOTS

Cat. C



ROSA ANTICO

Marmi
Marble

Cat. D



DOVER WHITE

Cat. D



PORT BLACK

Marmi
Marble

Cat. D

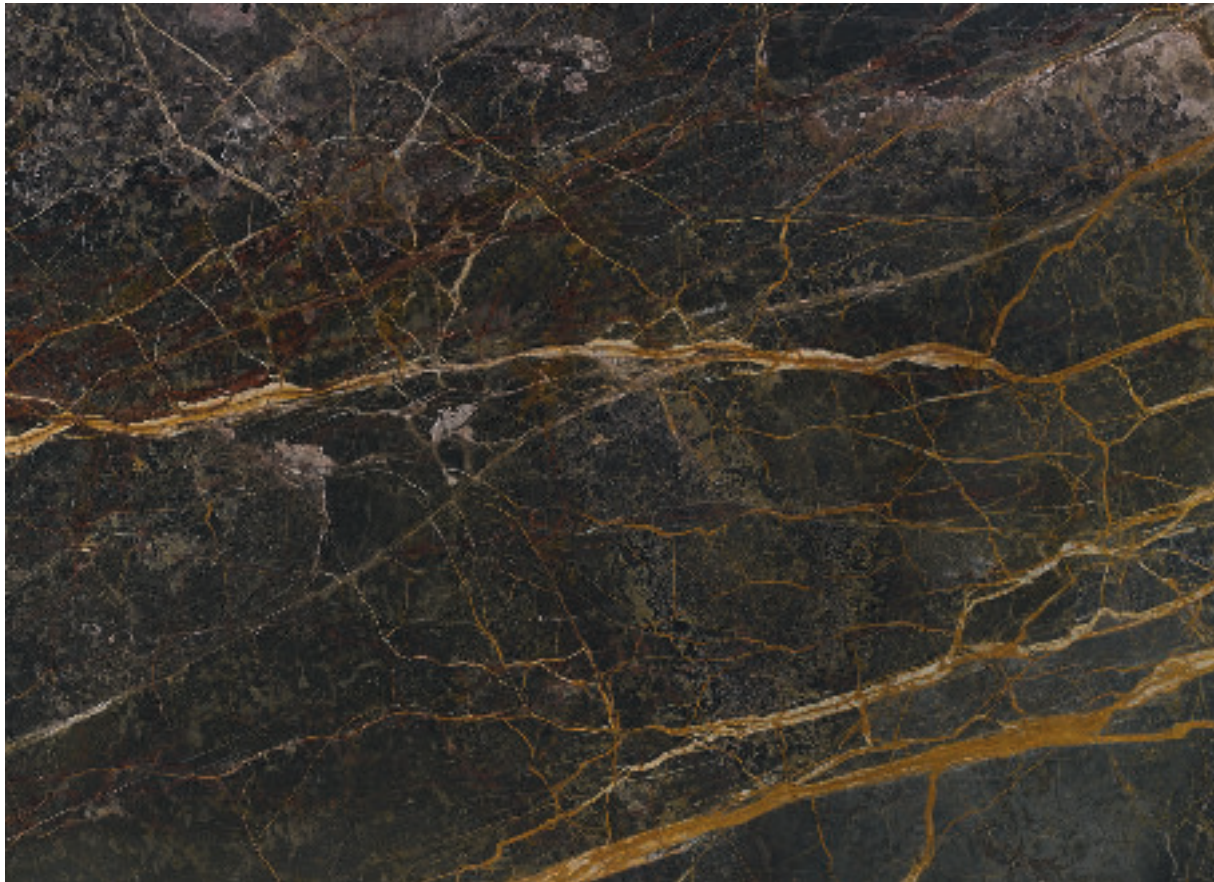

PORT SAINT LAURENT

Cat. E



ILLUSION

Marmi
Marble

Cat. E



SPIDERMAN

Cat. E



ELEGANT BROWN

Marmi
Marble

Cat. E

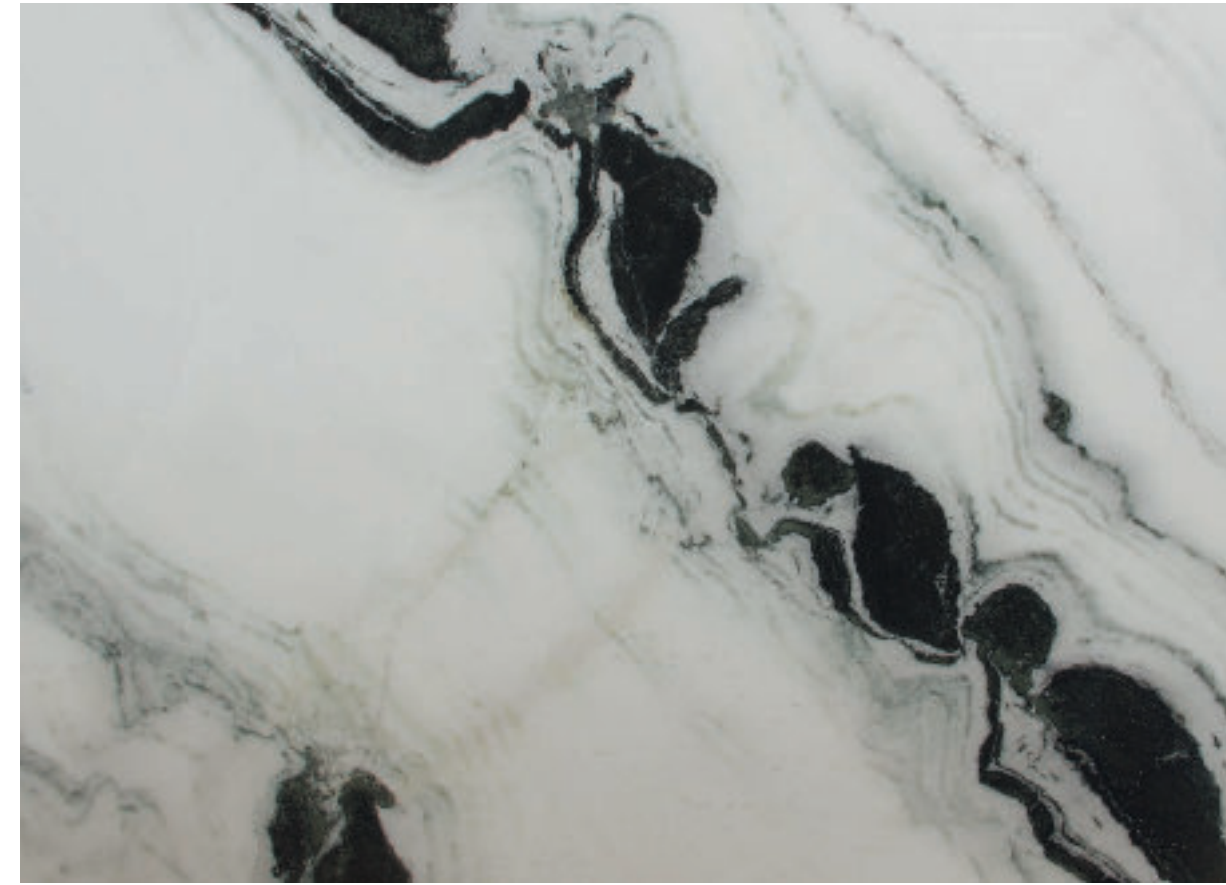

PANDA WHITE

Cat. F



CALACATTA ORO

Art Direction
DAINELLISTUDIO

Concept & Graphic Design
CHRISTIAN PARDINI
ROBERTO CIUCCOLI
STUDIO FLAT

Copywriting
ENRICA GALLO

Photography
STUDIO LEON
RICCARDO BIANCHI
STEFANO DE MONTE
STEFANO TONICELLO

Stylist
GIORGIA ANGELINI
CRISTINA BERNACCHI

Print
TAP GRAFICHE

© SIGNORINI&COCO
LUGLIO 2019

DAYTONA

Daytona | Luxury brand by Signorini&Coco

Signorini-Coco&C. Srl
Via Lazio 41 56035
Perignano (Pisa) IT
T. +39 0587 616198
F. +39 0587 617540
info@daytonahome.it
www.daytonahome.it

SHOWROOM MILANO
Via Alberico Albricci 9
20122 Milano IT
www.daytonahome.it

Signorini & Coco si riserva di apportare, senza preavviso, modifiche nei materiali, nei rivestimenti, nelle finiture e nei disegni dei prodotti presentati in questo catalogo. I colori dei materiali e delle finiture hanno un valore indicativo in quanto soggetti alle tolleranze dei processi di stampa.

Signorini & Coco reserves the right to make modifications to the materials, coatings, finishes and designs of the products presented in this catalogue without prior warning. The colours of the materials and finishes are purely an indication as they may differ slightly due to the printing processes.