

Disco
Guftram

THE COLLECTION

“FROM DISCOS TO MUSEUMS,
GUFRAM GOES BACK TO ITS ROOTS WITH THE RADICAL
70S STYLE THAT MADE IT AN ICON NOT ONLY OF DESIGN
BUT POPULAR CULTURE IN GENERAL.

ALL THANKS TO COLLABORATIONS WITH **ATELIER BIAGETTI**,
DUTCH COMPANY **ROTGANZEN** AND **GGSV** FROM FRANCE,
WHO, DRAWING ON THE CONCEPT OF DISCO-NOSTALGIA,
HAVE PRODUCED THREE IRONIC COLLECTIONS OF OBJECTS THAT
HARK BACK TO THE AGE OF THE DANCE FLOOR.

SOFAS, RUGS AND FURNITURE
IN ABSOLUTE GUFRAM STYLE DECORATE A SPACE THAT IS DESIGNED
TO OVERCOME TODAY’S MUCH-ABUSED VINTAGE ICONOGRAPHY
AND MAKE US REFLECT ON THE COMPANY’S HISTORICAL RELATIONSHIP
WITH THIS KIND OF PRODUCT,
AS WELL AS THE FLEETING VALUE OF GLAMOUR,
FOREVER TEETERING ON THAT FINE LINE THAT SEPARATES
HISTORY FROM FASHION AND MELANCHOLY
FROM THE PHANTOM OF ARTISTIC RESURRECTION”

LUCA TOSCANO OTTO - ZERO.EU













SEATS BY ATELIER BIAGETTI

**STANLEY, JIMMY,
BETSY, CHARLY, TONY**

STANLEY

Stanley, padded with soft and sinuous lines, is characterized by the postmodern aesthetics of its design. Proposed in a series of elements that allow you to build a completely tailor-made settee, creating different configurations according to your needs, it has a deep seat and wide enveloping armrests: it is the perfect project designed to transform your living room into a real cinema.

Presented with a purple velvet lining, it can be customized with velvets and other available textiles in a wide range of vibrant and deep colors. The particular tone-on-tone quilting of the upholstery creates a lively surface and gives rise to a sensual decorative motif that embellishes the product.

Stanley's peculiarity is the laminated mirror surface that defines its side panels: an unexpected touch, a subtle reference to the aesthetics alinked to the world of discos.





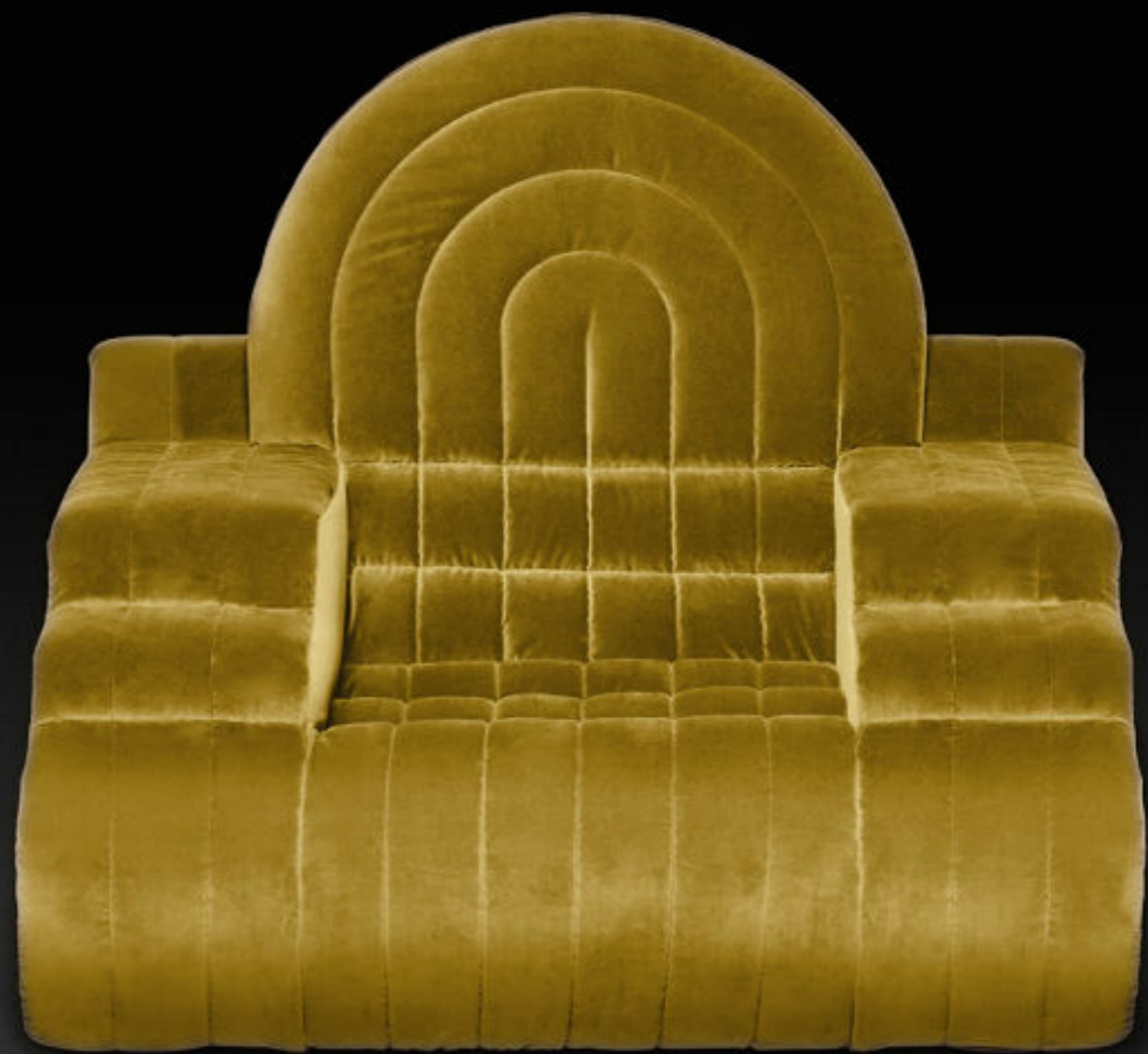

STY COMP

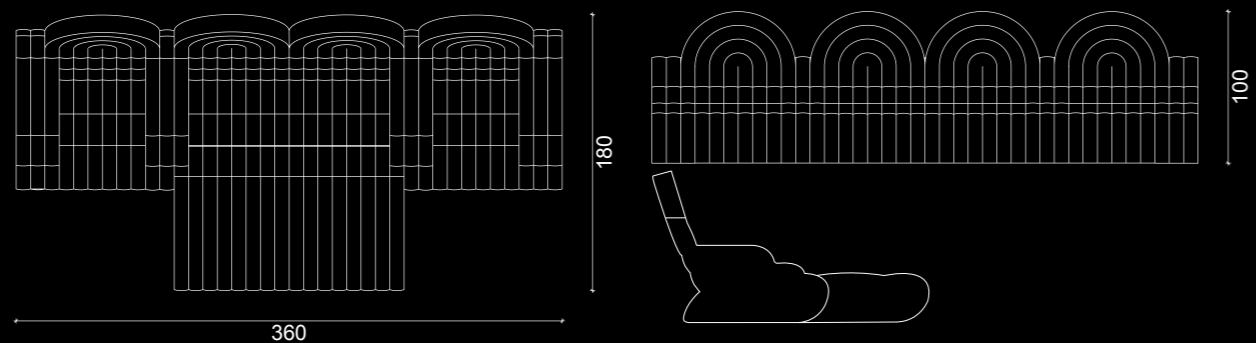

STY 190

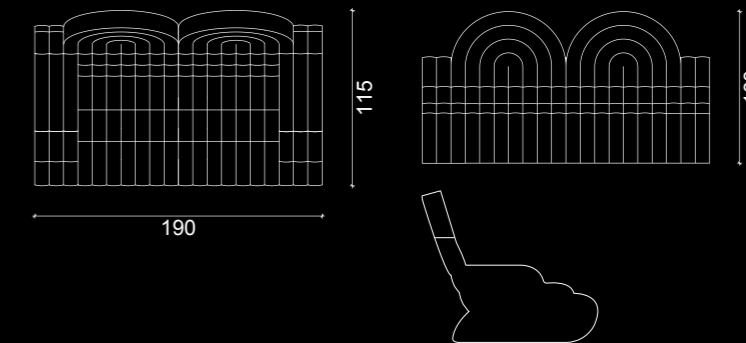

STY LOUNGE 02

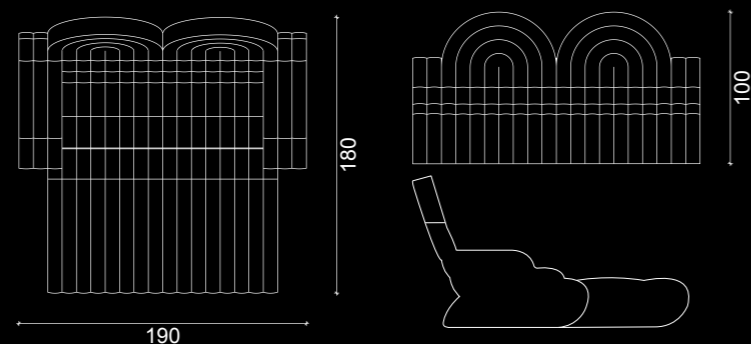

STY 115

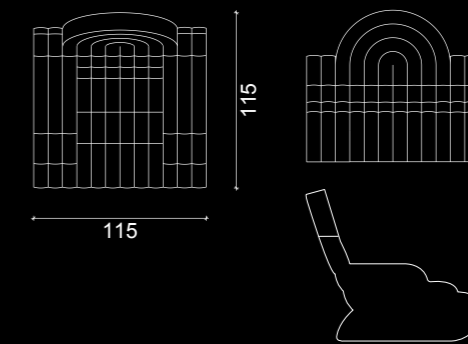

STY BED 02

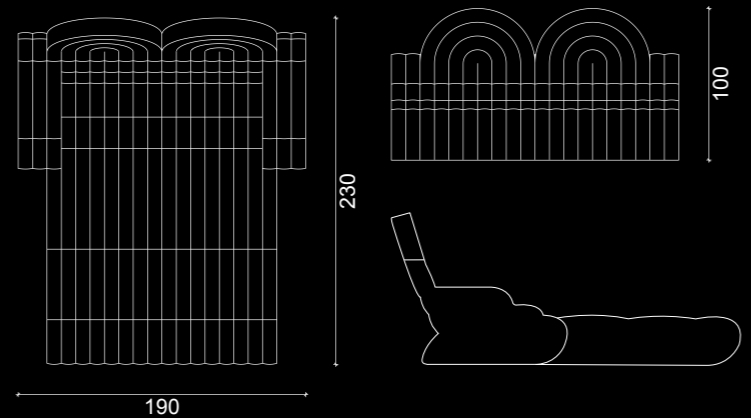

STY OTT 135

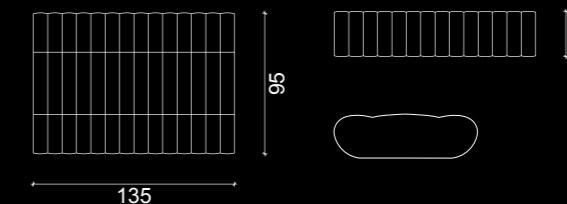

STY 265

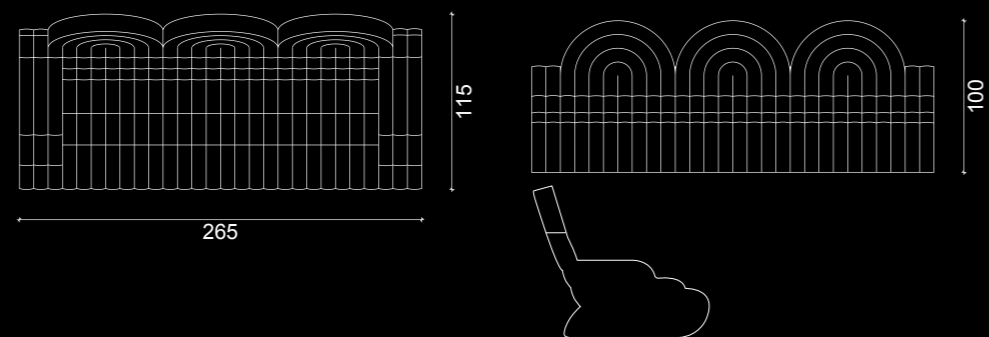

MATERIALS

Wooden structure, polyurethane foam padding, fabric upholstery, reflecting laminated side panels.

CUSTOMIZATION

The images in the preceding pages show Stanley with velvet upholstery. Stanley's upholstery may also be made with premium eco-leather, and, upon a feasibility evaluation, with fabric provided by the customer. To see and choose among the different combinations of colors and fabrics, please refer to the Disco Gufram selection.

ALL DIMENSIONS ARE EXPRESSED IN CENTIMETERS - THE CODES HIGHLIGHTED IN YELLOW REFER TO PRODUCTS SHOWN IN THE PRECEDING PAGES

JIMMY

Ideally modular ad infinitum, Jimmy is a lively unconventional and totally customizable seating system.

Between the versions it was conceived – concave and convex – are an invitation to play with its shapes and their orientation, with which even a gigantic circular shape can be created: it is this attitude that makes it the ideal protagonist of spaces with diverse need, be they domestic – living rooms, studios – or contract – halls of museums, buildings, or hotels.

Its transgressive and provocative personality is accentuated by the premium eco-leather upholstery with which it is presented, and that is a continuation of the subtle and elegant gold structure that defines its sinuous lines.

The polyurethane foam padding is made up of tubular modules that make the seat and backrest a single soft and sparkling volume.



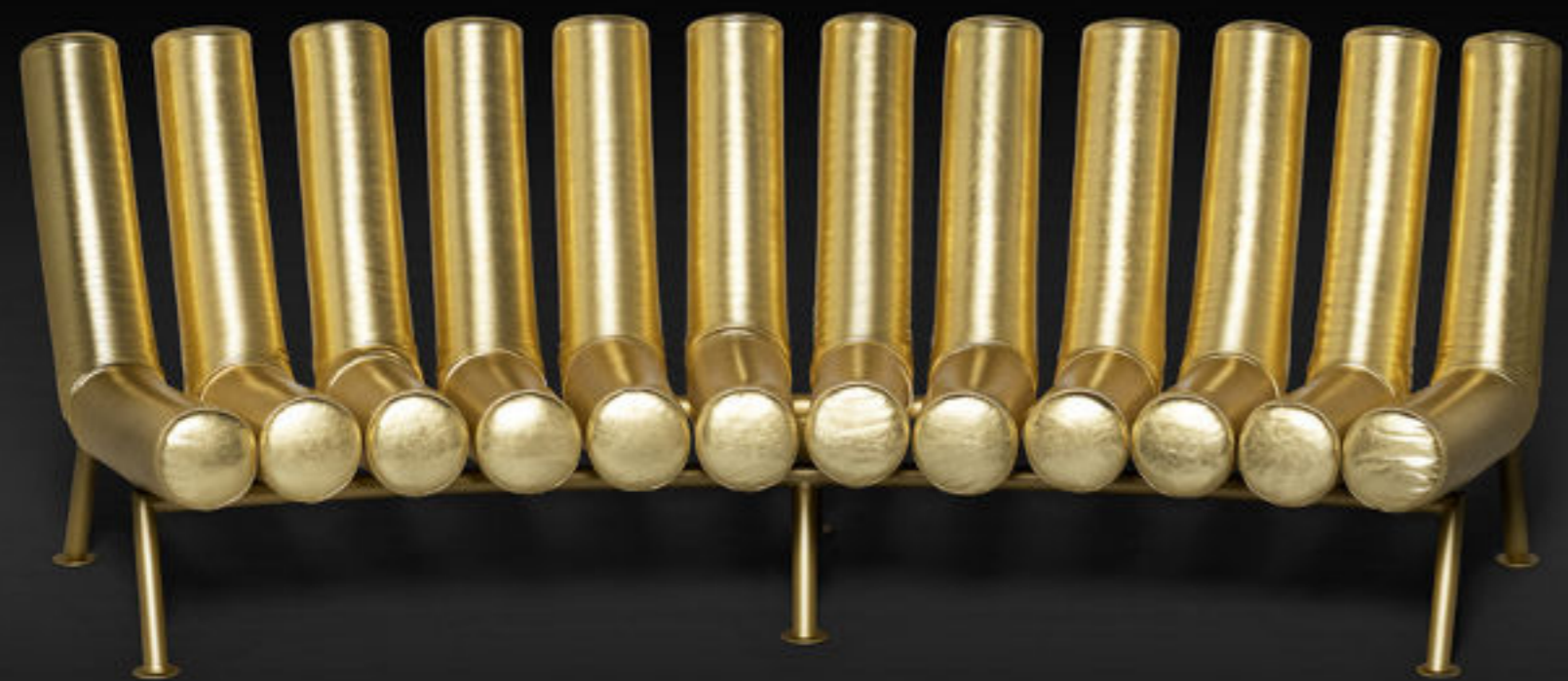

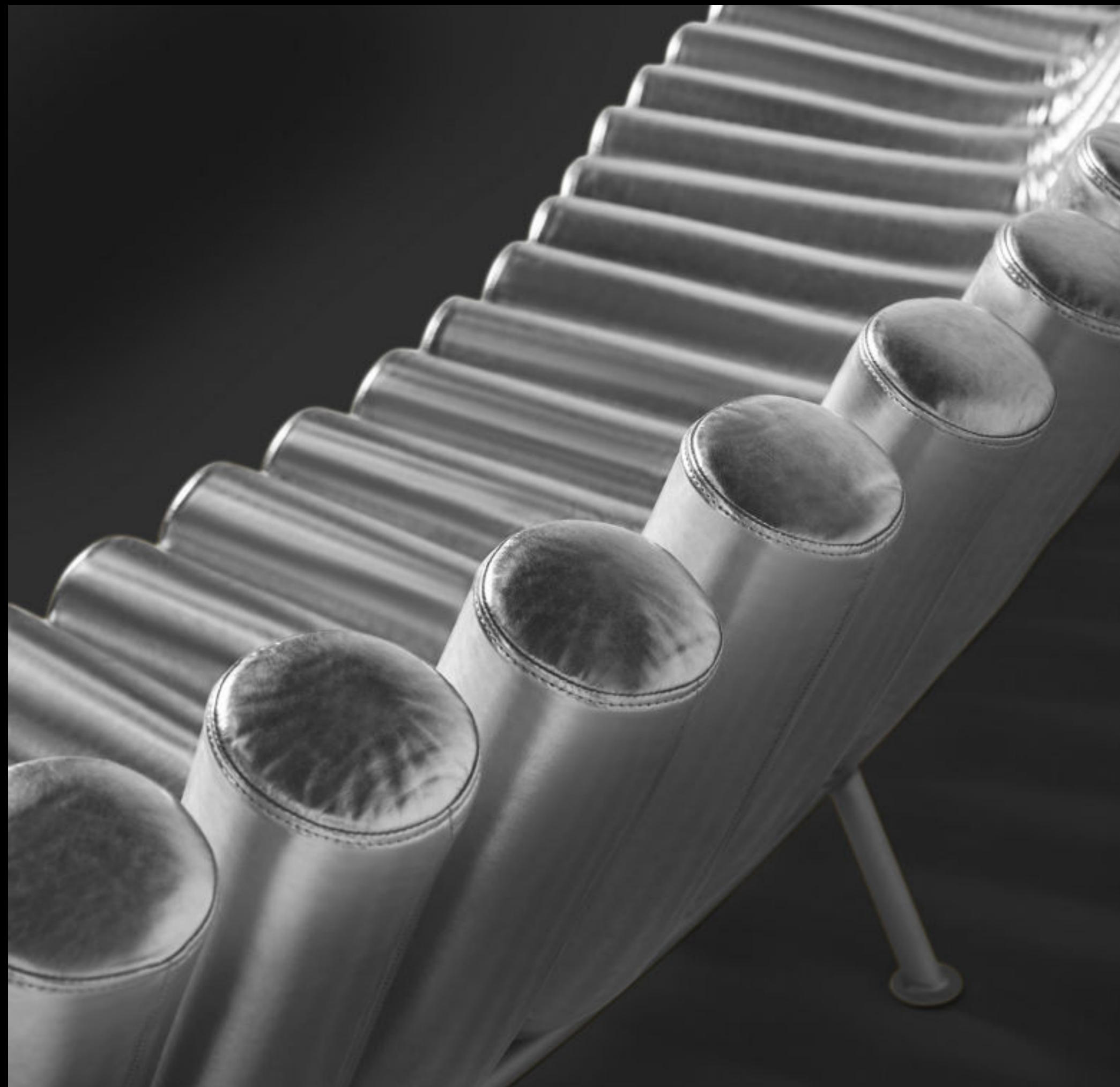

JMY CN 235

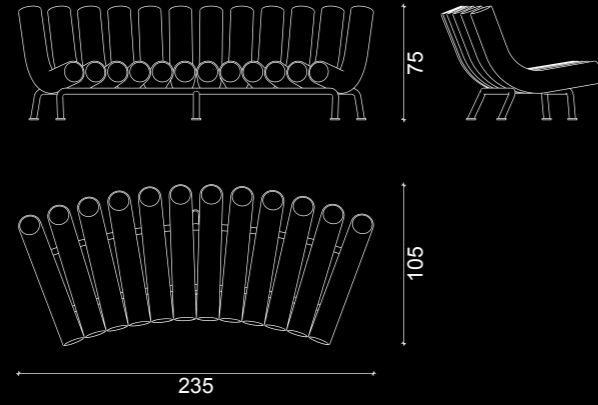

JMY CN 115

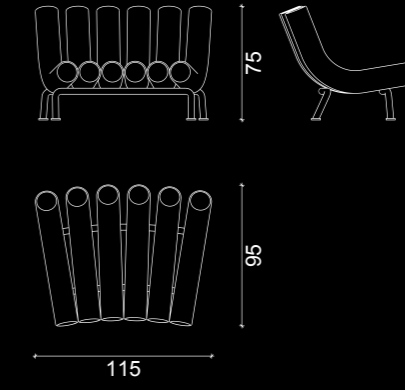

JMY CV 235

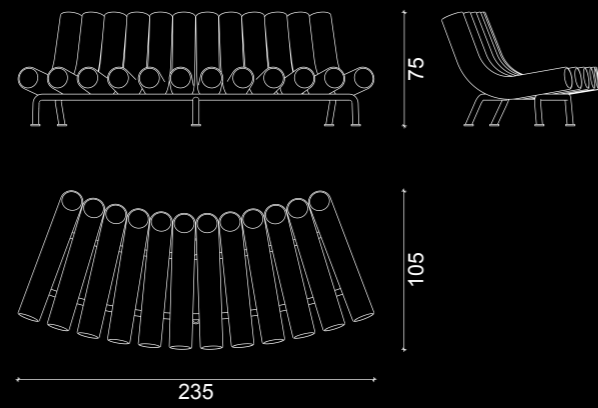

JMY CV 115

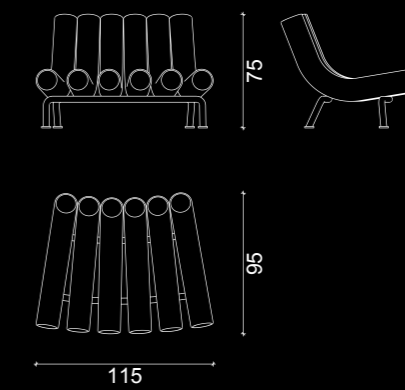

JMY 180

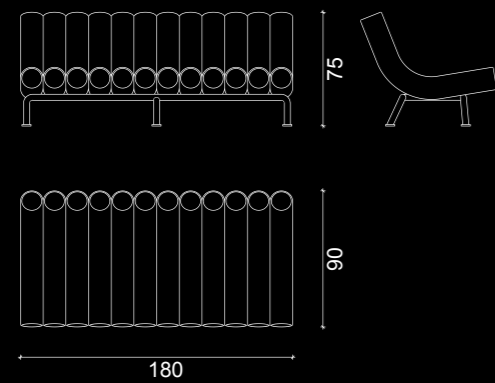

JMY 90

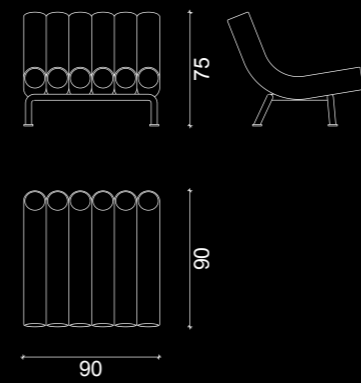

MATERIALS
Metal structure, polyurethane foam padding, removable fabric upholstery.

CUSTOMIZATION
The images in the preceding pages show Jimmy with shiny eco-leather upholstery. Jimmy's upholstery may also be made with velvet, coated fabrics, eco-leathers, and, upon a feasibility evaluation, with fabric provided by the customer. To see and choose among the different combinations of colors and fabrics, please refer to the Disco Gufram selection.

ALL DIMENSIONS ARE EXPRESSED IN CENTIMETERS - THE CODES HIGHLIGHTED IN YELLOW REFER TO PRODUCTS SHOWN IN THE PRECEDING PAGES

BETSY

Betsy is a couch with soft and enveloping lines that boasts of its fluidity and is distinguished by its visual comfort, thanks to its deep cushions and wide curved armrests.

The vibrant ripples and abundant pleating done as if the fabric were free and not upholstered declare its inviting comfort, making it sort of a surreal project.

Designed in three-seater, two-seater and armchair versions, it is presented in a shimmering and very luminous velvet that highlights its voluptuous aesthetics.

Also available in cotton and in different colors, Betsy, thanks to the soft padding designed for maximum comfort, is a couch that declares its vocation for total relaxation.



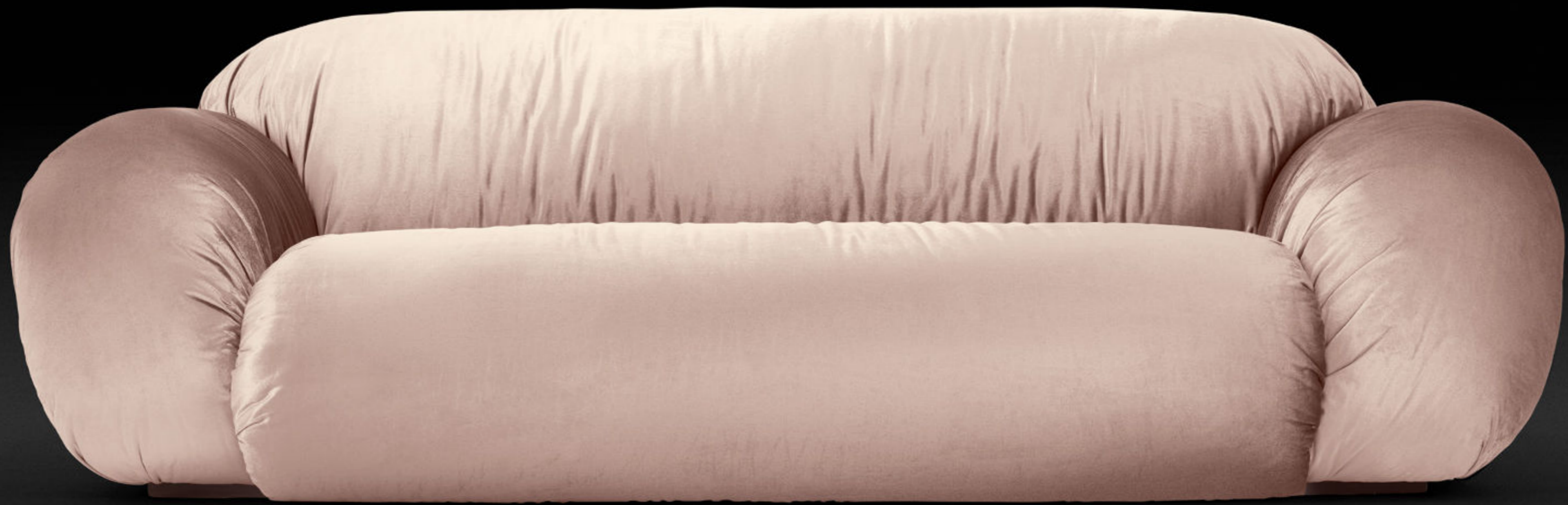



BTY 240

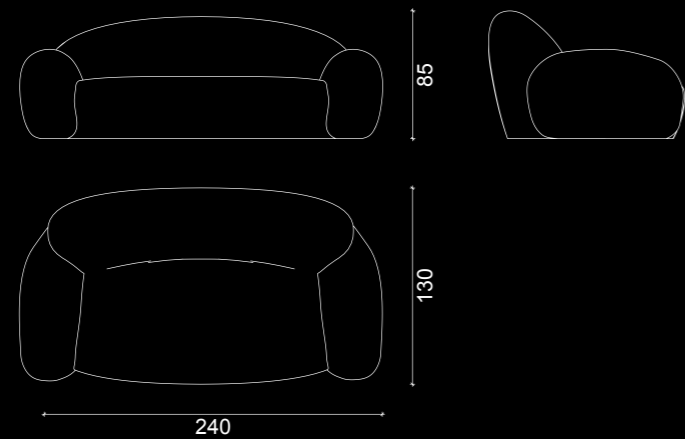

BTY 090

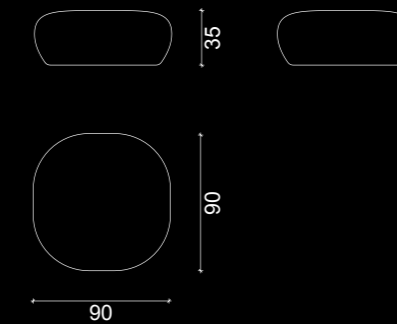

BTY 200

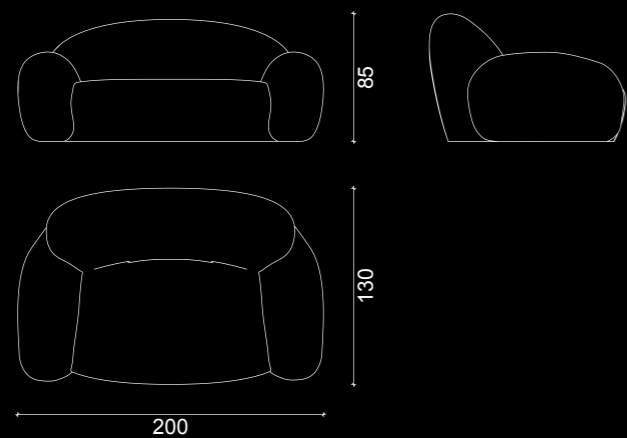

BTY 150

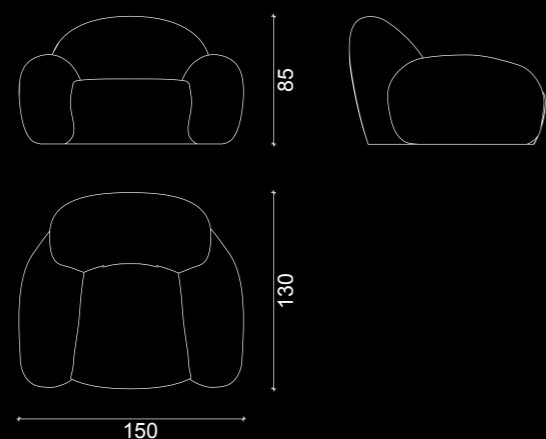

MATERIALS

Wooden structure, polyurethane foam padding, fabric upholstery.

CUSTOMIZATION

The images in the preceding pages show Betsy with shiny velvet upholstery. Betsy's upholstery may also be made with velvet, natural fibers such as wool or cotton, and, upon a feasibility evaluation, with fabric provided by the customer. To see and choose among the different combinations of colors and fabrics, please refer to the Disco Gufram selection.

ALL DIMENSIONS ARE EXPRESSED IN CENTIMETERS - THE CODES HIGHLIGHTED IN YELLOW REFER TO PRODUCTS SHOWN IN THE PRECEDING PAGES

CHARLY

Charly is a padded seat that stands out for its unexpected design that enhances the primary elements that compose it – seat, armrests, backrest, headrest – joined by a light and elegant tubular structure, which is either chrome-plated or satinized in precious metallic tones.

An unconventional seat with unstructured aesthetics, Charly is the king of modularity: as a matter of fact, it surprises because of the numerous combinations that it offers, in terms of configurations – the abacus of modules is rich in variations, but also of fabrics and colors that can be chosen and combined for the different elements.

Essential geometric shapes, as well as round and enveloping lines, define the design of a seat with an ironic and revolutionary mood.









CHY PG 190

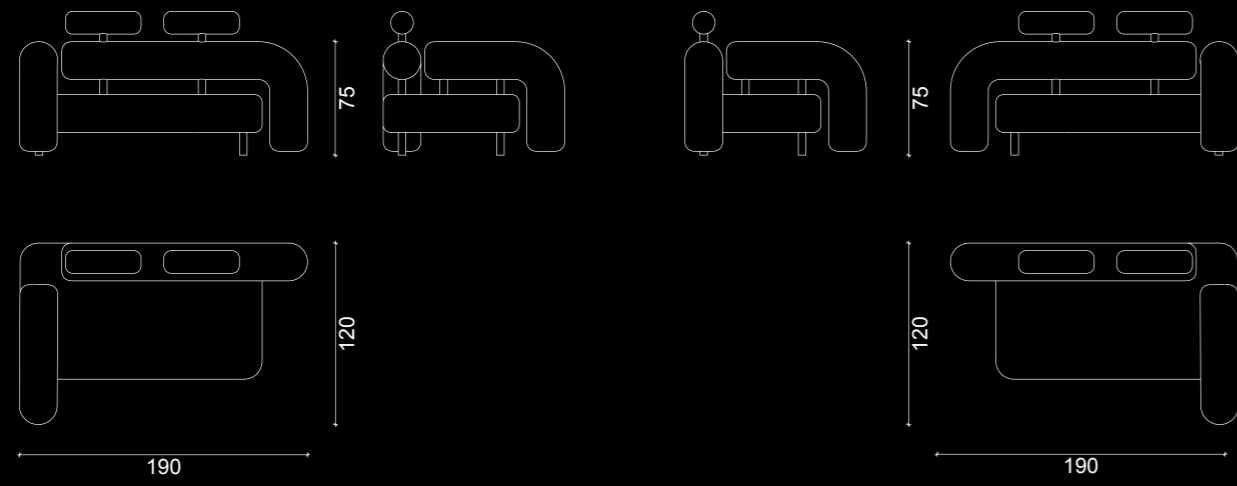

CHY GM 120

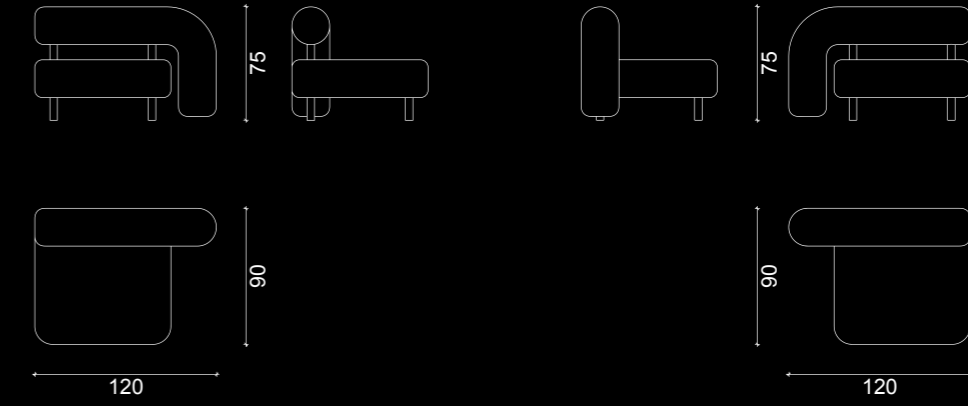

CHY GM 270

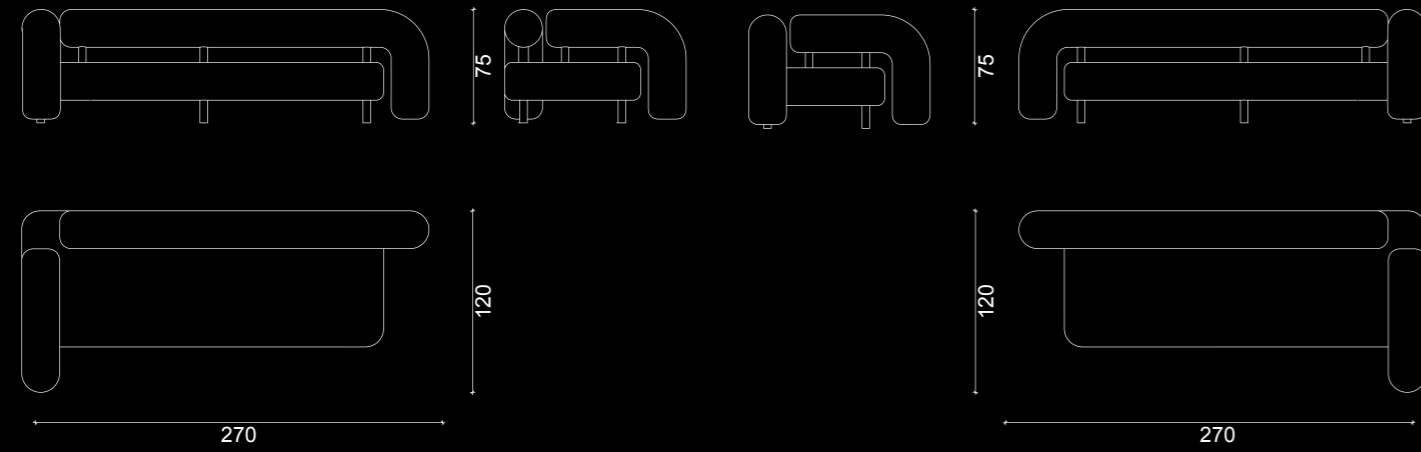

CHY ANG 90

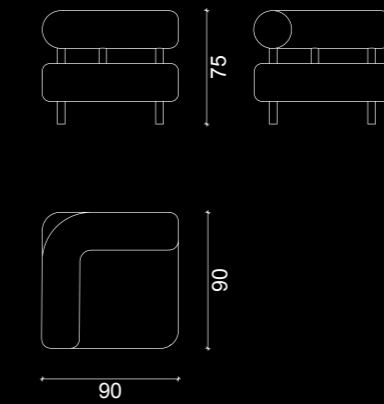

CHY 160

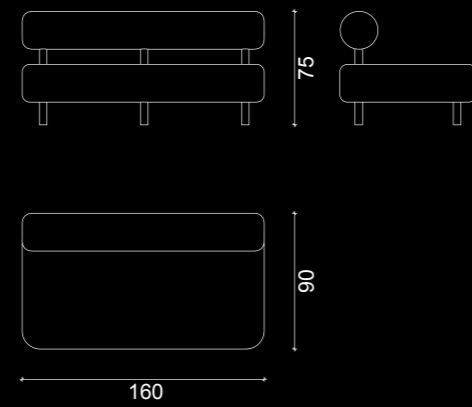

CHY 90

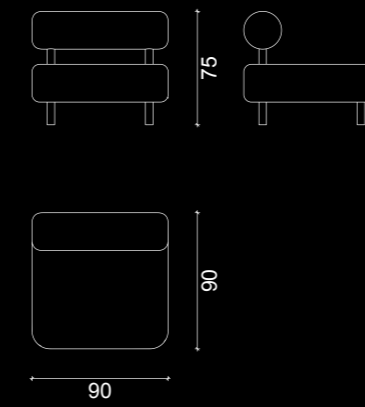

CHY OTT

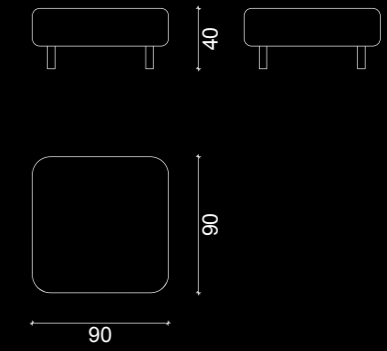

CHY CH LN 160

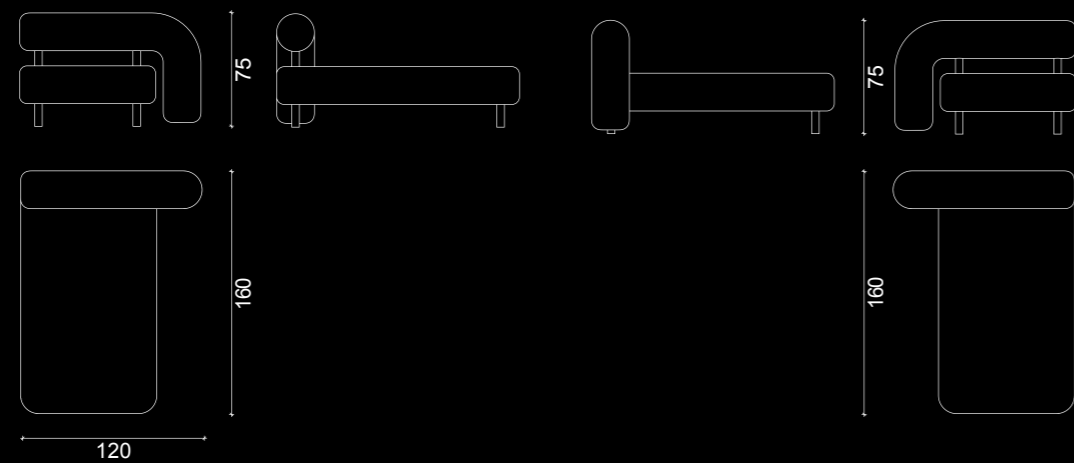

MATERIALS

Metal structure, polyurethane foam padding, fabric upholstery.

CUSTOMIZATION

The images in the preceding pages show Charly with tartan and premium eco-fur upholstery. Charly's upholstery may also be made with natural - such as wool or cotton - or synthetic fibers, and, upon a feasibility evaluation, with fabric provided by the customer. To see and choose among the different combinations of colors and fabrics, please refer to the Disco Gufram selection.

ALL DIMENSIONS ARE EXPRESSED IN CENTIMETERS - THE CODES HIGHLIGHTED IN YELLOW REFER TO PRODUCTS SHOWN IN THE PRECEDING PAGES

TONY

Tony is a radical system of modular seating composed of spherical elements of different dimensions that can be combined together giving rise to an infinite series of combinations, thanks to the assembly of the various parts which is possible through a system of special stops.

The sensual shapes of the different elements – which multiply on a different scale, reshaping themselves from large poufs to small cushions – are highlighted by the unique weave of the fabric that characterizes the covering, giving the surfaces an unexpected touch.

Available in a range of metallic and iridescent colors, quilted with a precious relief labyrinth-like design, Tony is an original seating system, designed for the most dynamic and transversal environments.

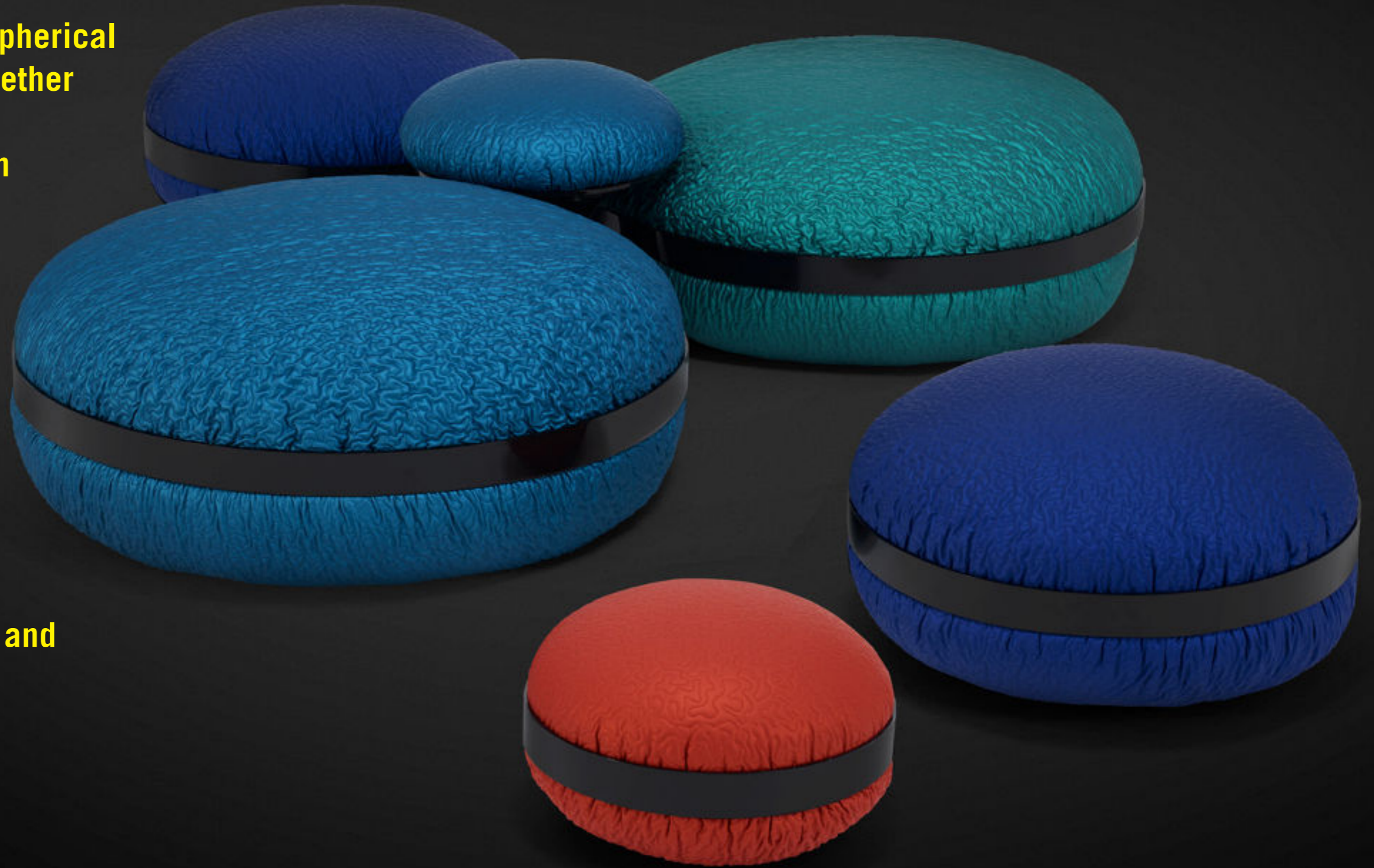

TNY 120

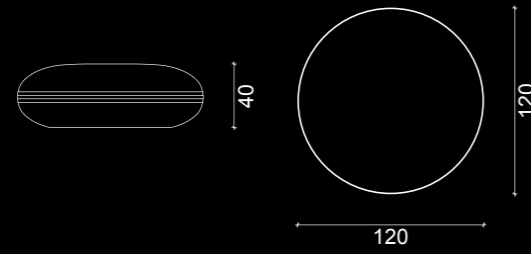

TNY 90

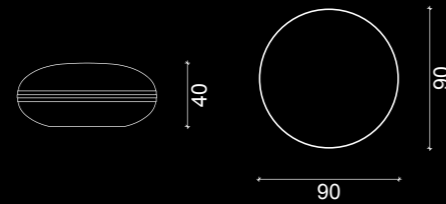

TNY 50

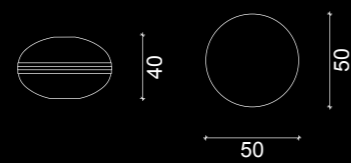

TNY 50 TB

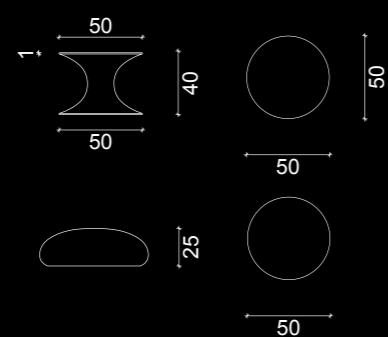

MATERIALS

Wooden structure, polyurethane foam padding, fabric upholstery.

CUSTOMIZATION

The images in the preceding pages show Tony with fabric upholstery. Tony's upholstery may also be made with velvet, and, upon a feasibility evaluation, with fabric provided by the customer. To see and choose among the different combinations of colors and fabrics, please refer to the Disco Gufram selection.

ALL DIMENSIONS ARE EXPRESSED IN CENTIMETERS - THE CODES HIGHLIGHTED IN YELLOW REFER TO PRODUCTS SHOWN IN THE PRECEDING PAGES

CABINETS AND LOW TABLES
BY ROTGANZEN

THE AFTER PARTY SERIES

THE AFTER PARTY SERIES

After Party is a series of storage units that reinterprets the world of clubbing in a unique and ironic way.

The emblematic disco ball in reflecting mirrors, a not-to-be-missed icon of the night world, acquires a new character, transforming itself into the characterizing element of the three cabinets and the two low tables of different dimensions that make up the collection.

The lacquered wooden structure, available in a palette of deep colors, is combined with the amorphous, almost liquefied forms of the sphere, whose surface consists of two-centimeter mirror tiles applied one by one by hand as in a Byzantine mosaic.

Elemental shapes light up in this way thanks to a radical touch: the result is a bright and original monolithic block with extremely contemporary reminiscences and practical but unexpected openings.





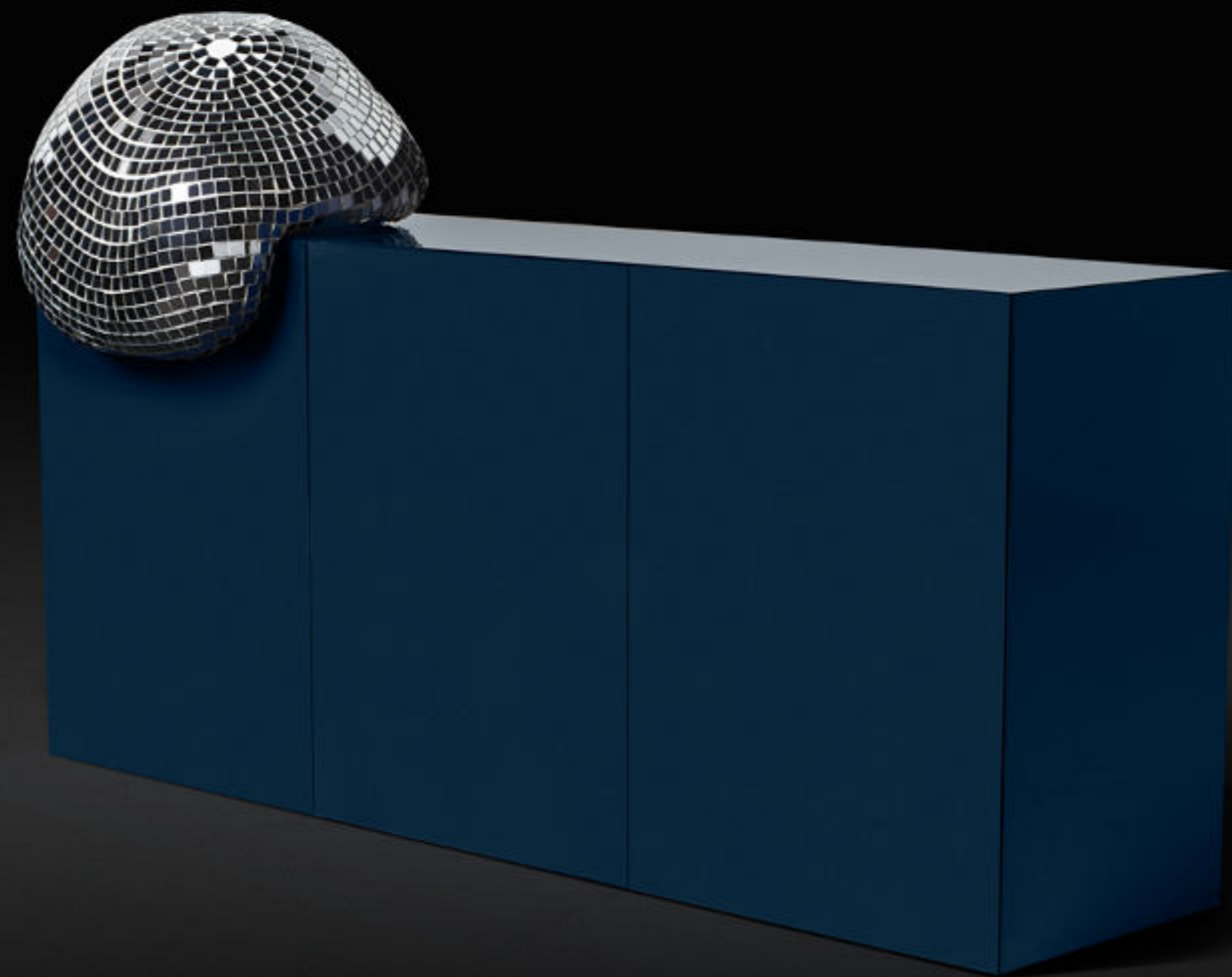

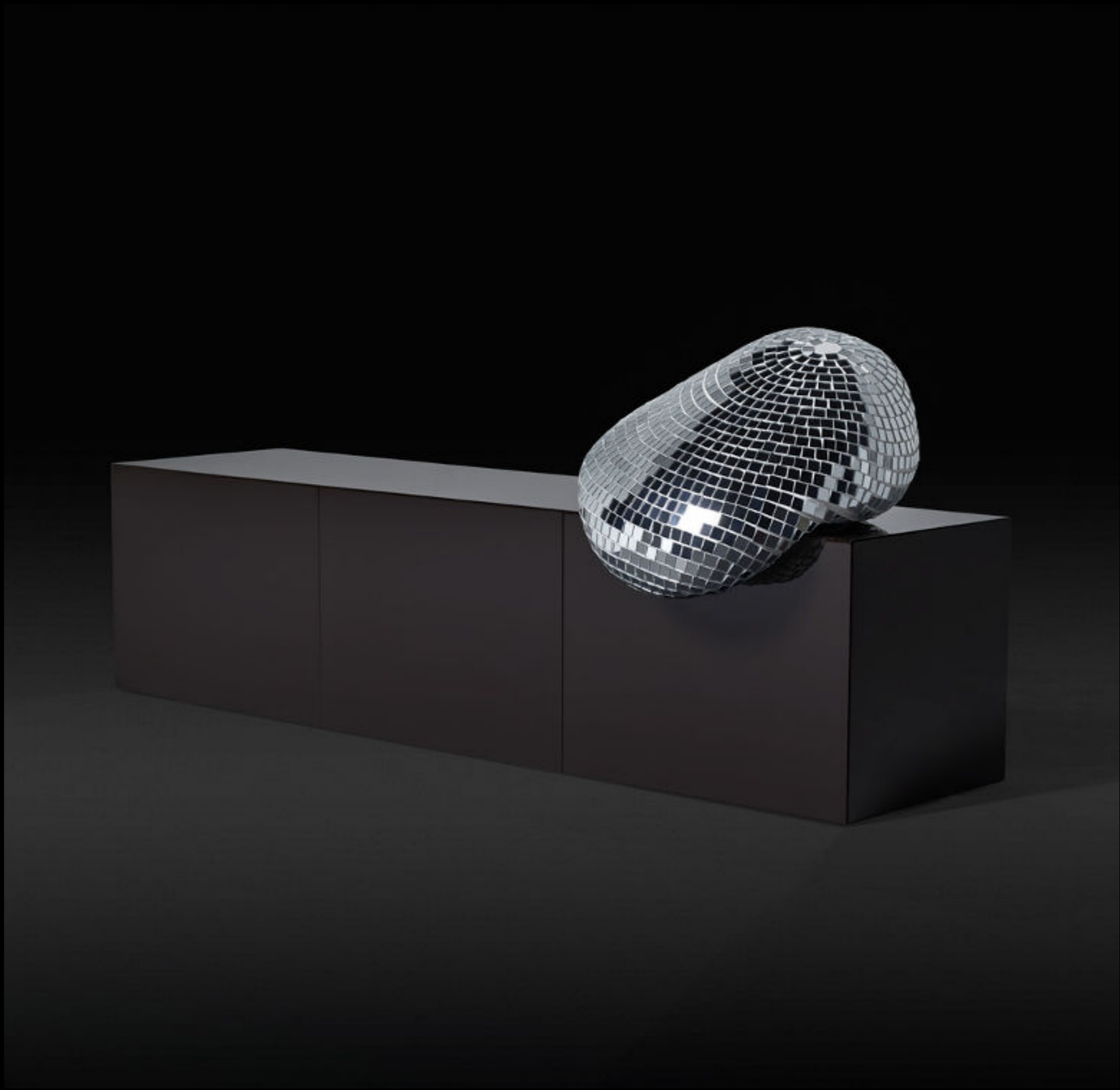



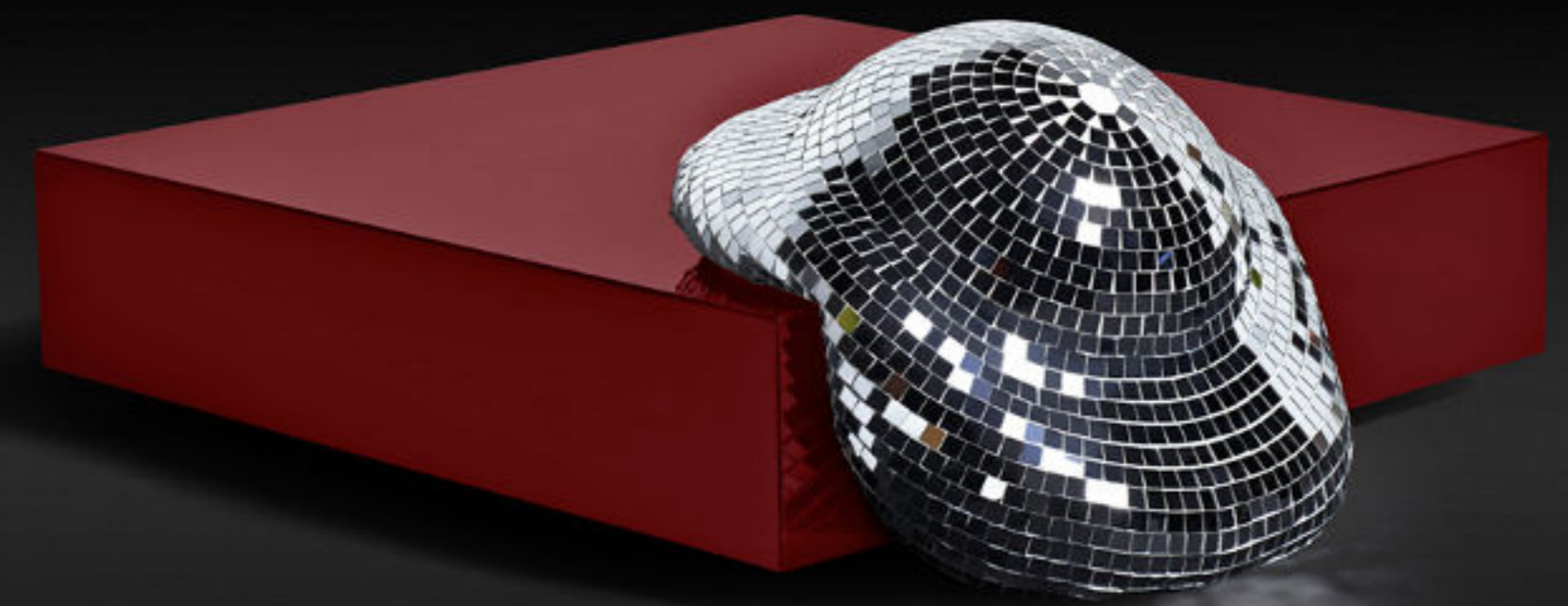

AP C HIG

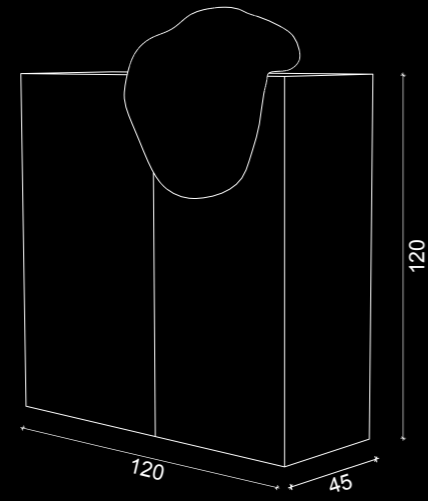

AP T SID

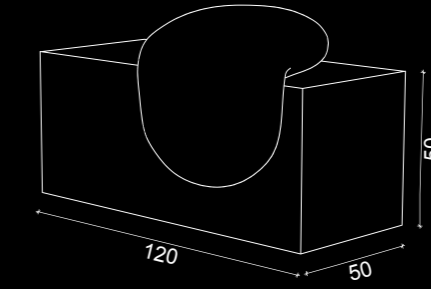

AP C MED

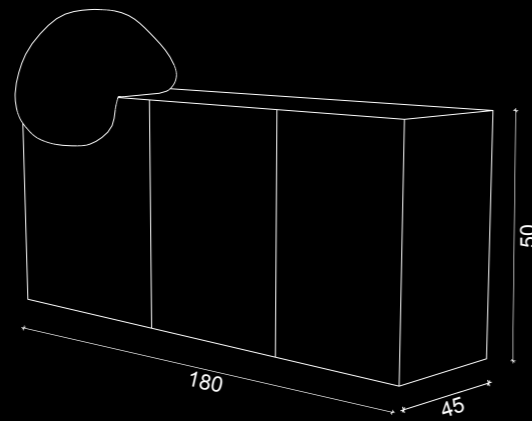

AP T COF

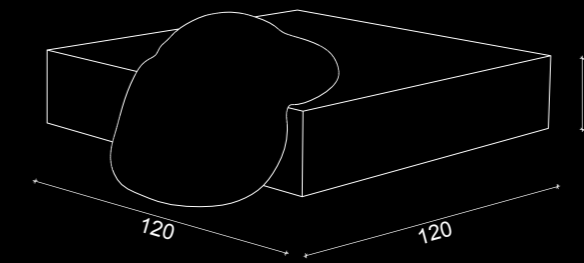

AP C LOW

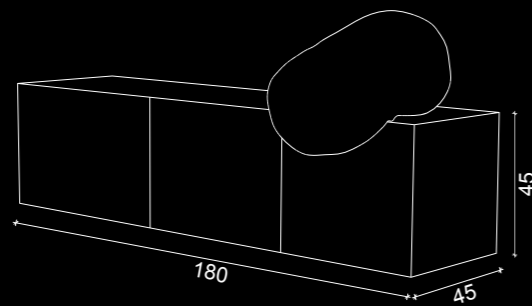

MATERIALS

Structure in lacquered wood, disco ball in expanded resin covered with mirrored glass tesserae.

CUSTOMIZATION

The After Party series is available in five RAL basic colors (RAL 5020 Ocean Blue | RAL 5011 Steel Blue | RAL 8019 Grey Brown | RAL 9005 Jet Black | RAL 3005 Wine Red). Upon request it is possible to choose another color of the RAL standard. The painting finish may be glossy or matte.

ALL DIMENSIONS ARE EXPRESSED IN CENTIMETERS - THE CODES HIGHLIGHTED IN YELLOW REFER TO PRODUCTS SHOWN IN THE PRECEDING PAGES

CARPETS BY GGSV

THE DANCE FLOOR SERIES

DANCE FLOOR SERIES

Dance Floor is a project with disruptive and timeless energy that consists of rugs with surprising shapes – circular, long and thin, all round – which play in a unique way with the optical deception of three-dimensionality.

Curved and concentric lines determine the movement of the surfaces, which are characterized by a definition and a depth of color without equal.

Available in blue, pink and gold shades, the Dance Floor rugs, thanks to their big dimensions, are able to radically transform spaces: the disco mood invades the home with an energy that floors perception.

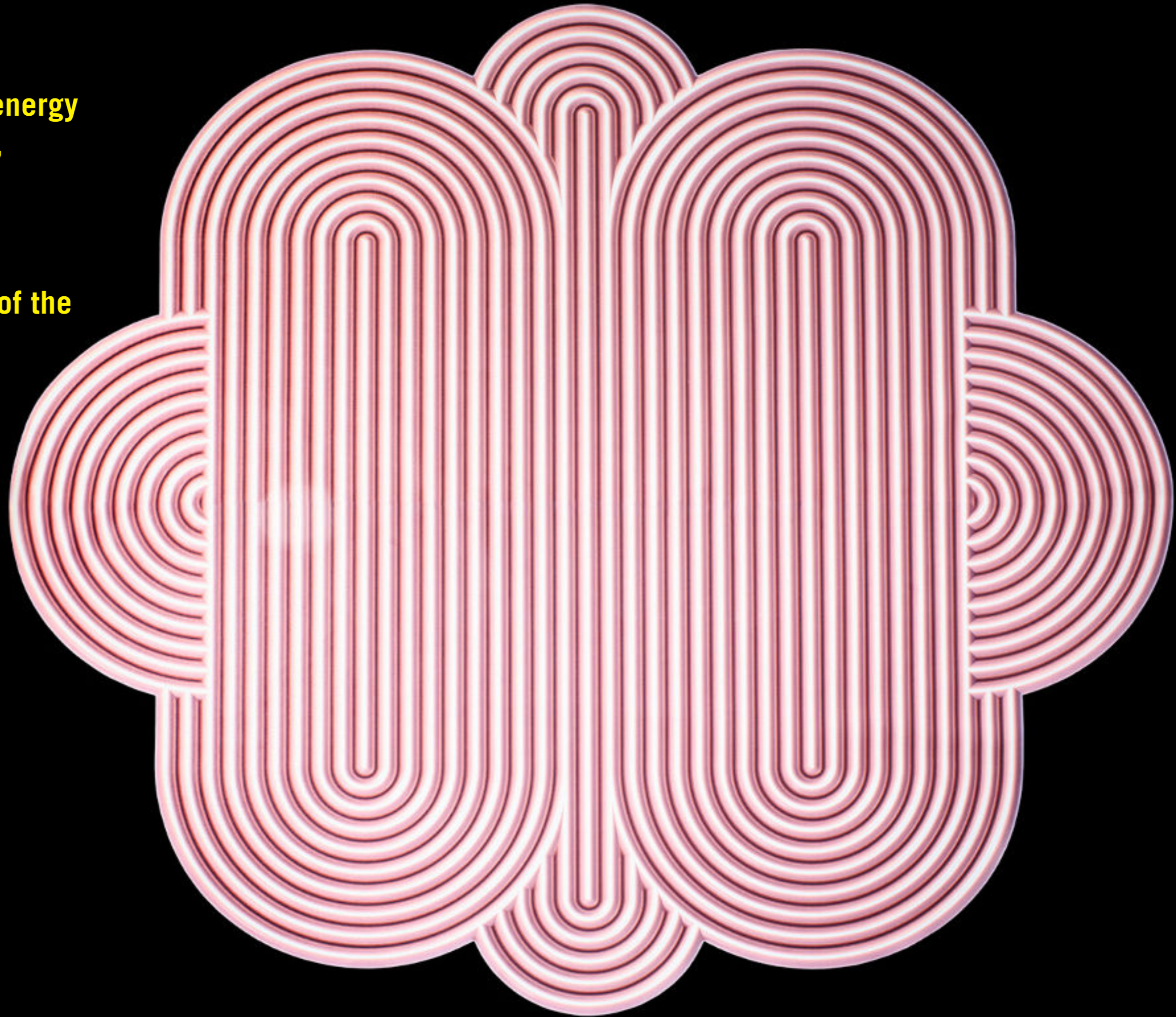





DF MIRAGE

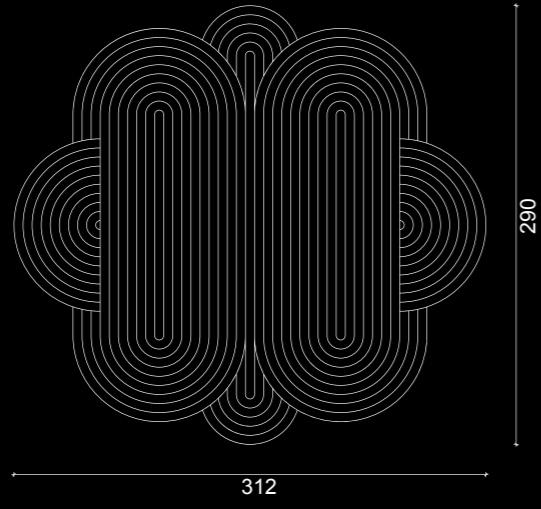

DF HORIZON

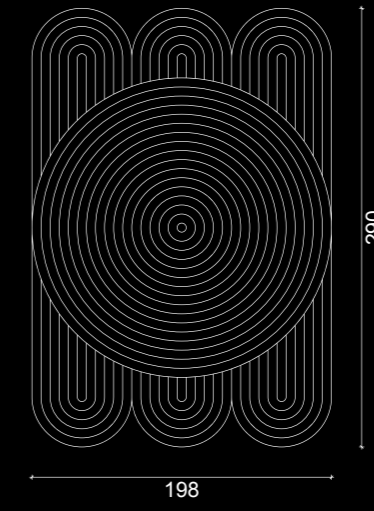

DF INFINITY

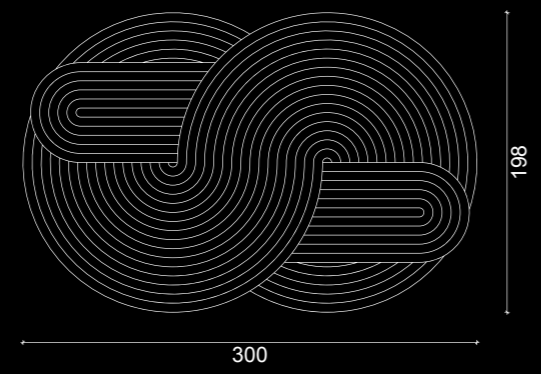

MATERIALS
100% tufted and printed polyamide.

CUSTOMIZATION
Each carpet shape of the Dance Floor series is available in three different colors (BLUE, PINK, GOLDEN).

ALL DIMENSIONS ARE EXPRESSED IN CENTIMETERS - THE CODES HIGHLIGHTED IN YELLOW REFER TO PRODUCTS SHOWN IN THE PRECEDING PAGES

©GUFRAM V 1.0 – 07 / 2018

IMAGES

PIERPAOLO FERRARI
LEONARDO SCOTTI
MATTIA IOTTI

PROJECT AND LAYOUT

SEBASTIANO MASTROENI
MYRIAM EL ASSIL

THANKS TO
TOILETPAPER

The tone of the colors of the different materials cannot be faithfully reproduced when printed on paper; It is thus to be considered as an illustration, and may not constitute grounds for claim or return of the product.

The images and data present in this catalogue are indicative. Gufram reserves the right to make any changes or improvements to the items illustrated, even without notice. Our sales offices remain at your disposal for any further clarification.

All rights are reserved. No part of this book may be reproduced, stored in a retrieval system, or transmitted in any form, by any means, be it mechanical, electrical, photocopying, recording or otherwise, without the prior written permission of the publisher.

The copyright of photographic reproductions used in this volume belongs to its relative owners. The products and anything photographically reproduced in this volume are intellectual works of which Gufram, in agreement with the authors, exclusively holds all the image and exploitation rights. It is therefore forbidden to systematically reproduce, even partially, and/or alter the images in this volume. It is therefore also forbidden to any third party to distribute and use the images in any form and/or by any means.

GUFRAM SRL | VIA ALBA 26 - 12060 BAROLO (CN), ITALY | +39 0173 56102 | INFO@GUFRAM.IT

DISCOGUFRAM.COM